



2026

**MSA STANDING SUPPLEMENTARY
AND TECHNICAL REGULATIONS**

DRAG RACING

VERSION 3

28 MAY 2026

WWW.MOTORSPORT.CO.ZA

REVIEW AND AMENDMENTS

Motorsport South Africa (MSA) will periodically review these rules and will present the revised version to all members for agreement to publish the updated version.

Amendments and updates to the rules will be recorded in the Amendment Record, detailing the updated version, date of approval of the amendment and a short summary of the amendment.

AMENDMENT RECORD

Modified SSR / ART	Date applicable	Date of Publication	Clarifications
SSR 2.2.1	28.05.2026	28.05.2026	Regulation Addition
SSR 2.3	28.05.2026	28.05.2026	Regulation Addition
CR 36.1	28.05.2026	28.05.2026	Regulation Addition
SB 4	28.05.2026	28.05.2026	Regulation Addition
SB 24	28.05.2026	28.05.2026	Regulation Addition
PS 6	28.05.2026	28.05.2026	Regulation Addition
PS 23	28.05.2026	28.05.2026	Regulation Addition
TR 1.2.1	27.03.2026	27.03.2026	Regulation Addition

I N D E X

1.	THE BASICS OF DRAG RACING	
2.	REGIONAL/CLUB CHAMPIONSHIP, DRAG RACING CATEGORIES AND CLASSES	
3.	CHAMPIONSHIP AND CHALLENGE COMPETITION POINT SCORING	
4.	DRAG RACING RULES, REGULATIONS AND SPECIFICATIONS	
5.	TRACK AND SAFETY REGULATIONS	
6.	VEHICLE CONSTRUCTION AND GENERAL SAFETY REGULATIONS: (Click on links provided).	
	CR 1	AEROFOIL
	CR 2	ALIGNMENT
	CR 3	ANTI-BLOWBACK DEVICE
	CR 4	ARM RESTRAINTS
	CR 5	AUTOMATIC TRANSMISSION PROTECTION
	CR 6	AUTOMATIC TRANSMISSION GEAR SHIFTERS
	CR 7	BALLAST
	CR 8	BATTERIES
	CR 9	BATTERY LOCATION MARKERS
	CR10	BRAKES
	CR11	BURNOUTS
	CR12	CLUTCH
	CR13	COOLING SYSTEM
	CR14	DEFLECTOR PLATE
	CR15	DELAY BOXES
	CR16	DRIVELINES
	CR17	DRIVELINE ANTI-ROTATION DEVICE
	CR18	DRIVER'S COMPARTMENT
	CR19	ENGINE
	CR20	ESCAPE HATCH (FUNNY CARS)
	CR21	EXHAUST
	CR22	FIRE EXTINGUISHERS AND FIRE BLANKETS
	CR23	FIRE BLANKET
	CR24	FIREWALLS
	CR25	FLASH SHIELDS
	CR26	FLOORS
	CR27	FLYWHEELS
	CR28	FLYWHEEL SHIELDS (Vehicles quicker than 11.99 seconds)
	CR29	FLYWHEEL SHIELDS
	CR30	FRAME/CHASSIS
	CR31	FUEL
	CR32	FUEL SYSTEMS AND FUEL TANKS
	CR33	GOGGLES
	CR34	HARMONIC BALANCERS
	CR35	HEAD PROTECTION
	CR36	HELMETS
	CR37	HYDRAZINE
	CR38	IGNITION SYSTEMS
	CR39	INTERCOOLERS
	CR40	INSPECTION
	CR41	JACK AND JACKSTANDS (TRESTLES)
	CR42	LATCHES
	CR43	LAUNCH CONTROL
	CR44	LIFTING DEVICES
	CR45	LIQUID OVERFLOW/CATCH TANKS
	CR46	MAGNAFLUX CERTIFICATES
	CR47	NITROUS OXIDE SYSTEMS
	CR48	NIGHT LIGHTING
	CR49	NUTS AND BOLTS
	CR50	OCCUPANTS
	CR51	OIL CONTAINMENT DEVICE (ENGINE)
	CR52	OIL SYSTEM
	CR53	PARACHUTES
	CR54	PARACHUTE RELEASE/RIP CORD
	CR55	PARACHUTE USE
	CR56	PINION SUPPORT
	CR57	PROPYLENE OXIDE
	CR58	PROTECTIVE CLOTHING
	CR59	PUSH BARS

	CR60	REAR-END
	CR61	ROLL BAR/CAGE GENERAL REGULATIONS
	CR62	"ROLL BAR" STRUCTURAL REQUIREMENTS – ALL ENCLOSED VEHICLES
	CR63	"ROLL CAGE" STRUCTURAL REQUIREMENTS – ALL ENCLOSED VEHICLES
	CR64	"ROLL CAGE" STRUCTURAL REQUIREMENTS – DRAGSTERS, FUNNY CARS
	CR65	SAFETY BELTS AND HARNESSSES
	CR66	SAFETY HUBS
	CR67	SEATING
	CR68	SHOCK ABSORBERS
	CR69	STARTERS
	CR70	STEERING
	CR71	STEERING WHEELS
	CR72	SUPERCHARGERS
	CR73	SUPERCHARGER RESTRAINTS
	CR74	SUSPENSION
	CR75	THREAD ENGAGEMENT INSPECTION HOLE
	CR76	THROTTLE LINKAGE
	CR77	TOWING RING/HOOK
	CR78	TOW VEHICLE
	CR79	TRACTION CONTROL
	CR80	TRANSMISSION
	CR81	TYRES
	CR82	VENT TUBES/BREATHERS
	CR83	WEIGHT
	CR84	WEIGHT DISTRIBUTION
	CR85	WHEELBASE
	CR86	WHEEL WELLS
	CR87	WHEELS
	CR88	WHEEL STUDS
	CR89	WHEELIE BARS
	CR90	WINDOW NETS
	CR91	WINDSCREENS AND WINDOWS
7.	CLASS REGULATIONS:	
	7.1	STREET CAR
	7.2	MODIFIED
	7.3	STREET DRAG RACING CLASS REGULATIONS FOR NON-CHAMPIONSHIP EVENTS
	7.4	JUNIOR CLASS CARS REGULATIONS FOR NON-CHAMPIONSHIP EVENTS
	7.5	MOTORCYCLE DRAG RACE RULES
	7.5.1	GENERAL
	7.5.2	SUPERSPORT SHOOTOUT
	7.5.3	SUPERBIKE ELIMINATION
	7.5.4	PRO-STREET
	7.5.5	TOP BIKE
	7.5.6	QUADS
8.	QUALIFYING, PAIRINGS AND LADDERS	

THE BASICS OF DRAG RACING

Drag Racing is an acceleration contest between two vehicles from a standing start, over a measured distance, usually the quarter mile. These contests are monitored by means of an electronic device, referred to as a "Christmas Tree". Two light beams connect to photocells on the track that are wired to the Tree and cross the start line. These light beams ensure that vehicles are positioned evenly. In turn, the beams are connected to electronic timers in the Control Tower. On launching off the start line, each driver/rider activates a timer that stops when the vehicle has reached the Finish Line. It goes without saying that each lane is timed independently of each other.

DB 1 THERE ARE THREE IMPORTANT TIMES RECORDED DURING A RUN:

1.1		Reaction Time: This is the time recorded as the green light is activated and the wheels of the vehicle move out of the stage beam. Reaction times are vital as these are what competitors have at their disposal to win a race. (See Fig.1).
1.2		E.T.: stands for Elapsed Time and it records the time as the front wheels of the vehicle move out of the stage beam, to when it cuts the finish line beam at the end of the quarter mile. (See Fig.1).
1.3		Speed (KPH): The third of course, is the terminal speed.

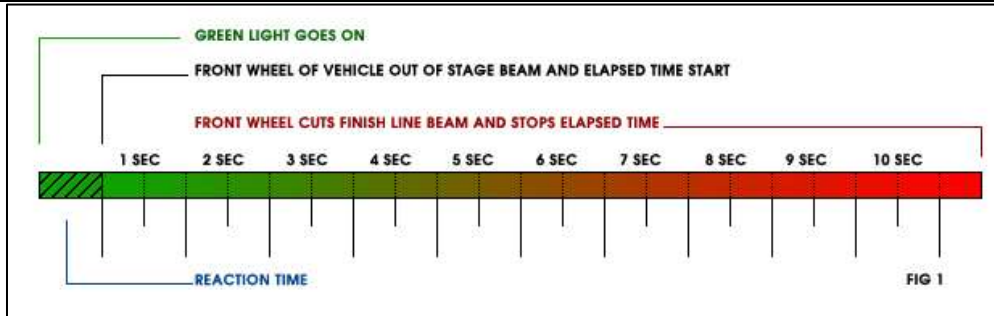

DB 2 REACTION TIMES

	2.1		Reaction times are vital as they are what competitors have at their disposal to win a race. The reaction time is recorded when the green light is activated to when the front wheels leave the "STAGE" beam. Comments have been received about slower cars always seeming to win. Whether a competitor is competing in handicap or heads-up racing, the quickest is not necessarily the winner. That is why "reaction times" are so important. A competitor may lose, regardless of whether his/her E.T. (Elapsed Time) was good. If the initial "reaction time" was loose, he/she could well lose the race. The faster the "reaction time", the more chance a competitor has of winning.
		2.1.1	Why is a Reaction Time important?
			Reaction Times have nothing to do with Elapsed Times (E.T.'s). The Reaction Time is measured before the Elapsed Time counter starts. It should be stated that racing is first and foremost about who crosses the finish line first, irrespective of how quick you were getting there. In order for any system to accurately determine a winner, it uses the "reaction time" and the "elapsed time" to calculate the "overall time". The "overall time" is calculated by adding the "reaction time" to the "elapsed time." If two competitors' race, the one with the lowest "overall time" is the one that crossed the finish line first.
			In (Fig.2 below), let's assume that we have two vehicles running identical elapsed times of 13.100 seconds, however, this doesn't necessarily mean that they both crossed the line in an identical fashion. The competitor who had the quickest reaction time (Competitor 2) will win as his vehicle moved out of the stage beam before the other (Competitor 1).
			Remember that the elapsed time only commences when the vehicles move and NOT when the green light goes on. The overall time of Competitor 2 is less than the overall time of Competitor 1.

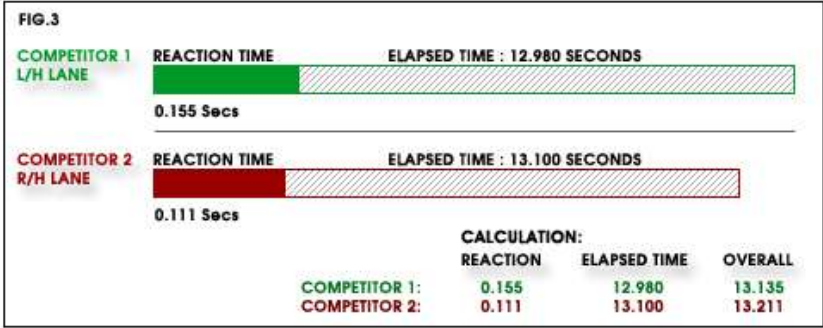
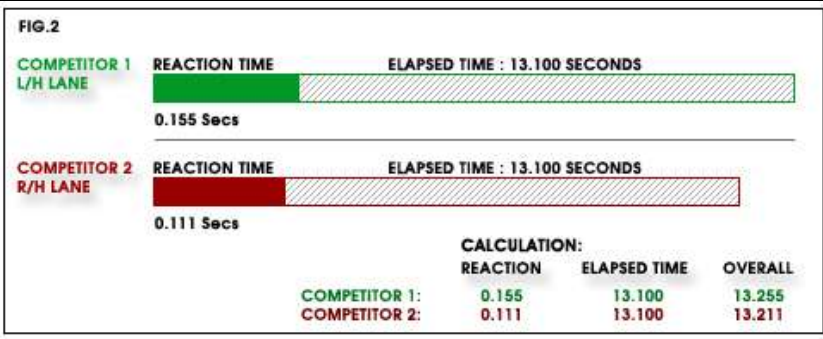

In Fig.3 above, Competitor 1 is the winner even with a slower reaction because his "OVERALL TIME" was less than Competitor 2. The difference in Elapsed Times superseded the difference in reaction time.

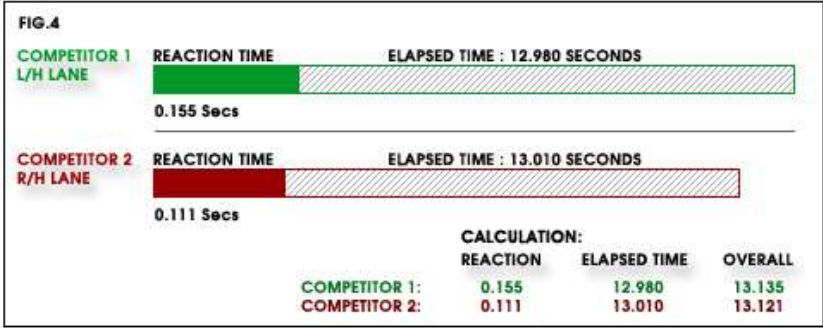

In Fig.4 above, Competitor 2 is the winner even with a slower elapsed time because his "OVERALL TIME" was less than Competitor 1. The difference in reaction time superseded the difference in elapsed time. This is one of the most confusing things to competitors and spectators alike unless they understand completely how "reaction time" and "elapsed time" work.

2.1.2

How do I get a "good" Reaction Time

A perfect reaction time is 0.000 seconds. A good reaction time in real drag racing terms is between 0.000 and 0.100; the closer to 0.000 the better. Following on from the sections on "STAGING" and the "CHRISTMAS TREE", "How to get a good reaction time", can now be explained.

A good reaction time is achieved by the driver's reaction to the Amber light signal and also the vehicle reaction to the accelerator. Any good drag racer won't wait for the green light to go on before reacting. This is why we have Amber Lights activating before the Green. The Amber lights are warning the driver that the green light will be activated at any moment; usual 0.4 seconds.

The driver should leave while the yellow light is still on as there is the "ROLLOUT" distance on the "STAGE" beam and the time for the vehicle to react after the driver has pushed the accelerator.

Frankly, if racing was all about fast cars, then why run the risk of putting two competitors up against each other, or more for that matter when you consider other forms of motorsport, athletics or even horse racing. If it was all about fast cars, then a single lane strip would suffice, where competitors could run time trials or top speed runs and not drag race two cars/bikes against each other to see

			who could cross the finish line first. In the professional categories running in the American NHRA drag series it is not the quickest or fastest car that usually wins but the driver with the best reaction time that supersedes his slower E.T. from that of his opponent. If a competitor is slipping and sliding or spinning their tires from overpowering, or incorrect clutch set-up, it follows that because he didn't adapt to the track conditions correctly, he will be eliminated from the competition. Any track must have reaction times in order to make it fair to all competitors.
DB 3	STAGING		
	3.1	All vehicles must stage on the front wheels, not the rear. Once a vehicle reaches the front of the staging lanes for a run, it must be prepared to fire and race. A vehicle must start and self-stage. It is not permitted to push start or push stage a vehicle. Please watch your own lane lights and not those of the opposition. Once the staging lights are activated, should a competitor roll forwards, he/she will receive a Red Light, which is considered a serious infraction. The same applies if a competitor rolls backwards. Once staged, it is vitally important that competitors remain absolutely still until the Green Light is displayed. If a Red Light is received, the competitor, albeit disqualified, must finish the race. There are no recalls on Red Lights.	
	3.1.1	What is Staging?	In order to run a fair drag race using electronic timing equipment, both competitors must start from exactly the same position in each lane. This position is called the "STAGE" beam. The front wheels of the vehicle activate the "STAGE" beam. By moving into the beam and breaking it with the wheels, it activates the "STAGE" light on the Christmas tree. When a vehicle is in STAGE, the vehicle must stand still until the tree is activated to start the race.
	3.1.2		Prior to activating the "STAGE" beam, competitors need to activate a "PRE-STAGE" beam. "PRE-STAGE" is an indication to the competitor that he is very near to the "STAGE" beam. Each of the beams has a certain amount of "ROLLOUT". "ROLLOUT" is the distance that the wheel is closing in on the beam. The "ROLLOUT" distance can vary slightly from track to track. It is approximately 10" (250mm) long when measured with a 22" diameter wheel.
	3.1.3	How to Stage:	When the vehicle moves forward and breaks the "PRE-STAGE" beam, the light will activate on the Christmas tree. The driver should then stop and slowly move forward until the "STAGE" light is also activated. At this point, both lights ("PRE-STAGE" AND "STAGE") are lit. The driver can now remain in this position or move forward until the "PRE-STAGE" light goes out and only the "STAGE" light is on. With only the "STAGE" light on, it means that the wheel has already covered approximately 1/3 of the "ROLLOUT" distance of "STAGE". In other words, the "ROLLOUT" is now reduced to approximately 6"-7" (150mm-175mm). In most cases, competitors leave both lights on. With both lights on, it is called "SHALLOW STAGE". With one light on, it is called "DEEP STAGE". This "ROLLOUT" distance plays a vital role in the reaction time as well as red lighting.
	3.1.4		If both competitors in each lane have moved through "Pre-Stage" into "Stage" (Re: Solidly, without stage flickering or merely "over staging"), it is automatically assumed that they are committed / ready to do the run. Once this has happened and any one competitor moves out of "Stage" (before amber sequence has started), the system will NOT start. The competitor who first starts a run (i.e.: Once staged solidly and not merely "over staging") before the amber sequence has started, will automatically be excluded (the loser). The second competitor will be the winner; however, it is pointed out that if he/she also started before the amber light sequence, (i.e.: Before race official (tree operator / timekeeper) could manually reset the system) no ET or Speed will be recorded and therefore lane-Choice will be forfeited for the next round. If any dispute arises from the losing competitor in the above-mentioned instance as to whether he/she has "over staged" or "started the run", the matter will be handed to start line officials, the tree operator/timekeeper, official judges of fact and their assistant judges/observers to make final decision.
DB 4	OFFICIAL QUALIFYING		
	4.1	Events will commence with a few practice rounds in order to test engine performance, traction, wind shear, etc., after which Official Qualifying (OQ) will commence. OQ comprises a minimum of two rounds, during which competitors have two chances to pump up their performances before main racing. Any competitor who fails to do at least one qualifying run, will not be included in the main eliminations. Competitors who red light during this section of the event, still qualify for main eliminations! Qualifying is purely to establish what times your vehicle is capable of running in order to set a dial-in / class time for main racing. National Championship events have the option of a dedicated day for OQ, i.e. OQ on Day 1 and eliminations on Day 2.	
DB 5	MSA LICENCE		
	All competitors must be in possession of a valid Drag Racing Competition Licence issued by Motorsport South Africa [MSA]. This licence must be submitted to the organisers when submitting an entry for the event.		

DB 6	DRIVER'S / RIDERS BRIEFING
	It is compulsory for all competitors to attend a Drivers/Riders Briefing. Failure to do so may lead to exclusion from competition, the day's racing or a penalty as determined by the Clerk of the Course.
DB 7	CONDUCT
	All competitors plus crew are to conduct themselves in an orderly manner. Any disorderly conduct or failure to obey official instructions or any breach of these regulations by entrants or their assistants, shall make the entrant concerned liable to a penalty and/or fine. If the offence occurs during a race, the entrant will face disqualification.
DB 8	FAMILY AND FRIENDS
	Family and friends are not permitted on the start-line. This area is restricted! The only people allowed to be on the start line are the racing competitors, 1 crew member each and start line marshals/officials. Two crew members are permitted only in the case of a vehicle equipped with a parachute. Remember that every time the track is closed, it delays proceedings that aggravate the organisers, competitors and public who are there to watch the racing. Please note that the minimum age for pit crew members allowed on the start line at an event is 16 years.
DB 9	DIAL-INS (HANDICAP)
	Each driver / rider nominates his or her own handicap or dial in time. However, no driver/rider may dial-in slower than his / her quickest qualifying time of the day. This is usually done by making two runs during official qualifying to see how slippery or sticky the track surface is at the start line and to see how much power the engine is pumping. Suppose a competitor runs a 14.4 and 14.2, knowing that if he beats his "Nominated Time" or "Handicap Time" even by one thousandth of a second, he will be disqualified. It would be stupid to dial in at 14.4. It would be just as dangerous to dial in at 14.2 because any improvement in the conditions such as traction, wind, and temperature or engine power could result in a better run being recorded, and disqualification. So, the safe thing to do is to give himself a safety margin of approximately one tenth of a second (depending on what type of vehicle and / or driver consistency, and / or track conditions, and / or vehicle consistency). Therefore nominate 14.2 less 0.1 = 14.1 seconds as a "Dial-in" time.
DB 10	NOMINATION OF COMPETITION CLASS
	For Championship events the handicap start system will not be used. Championship events will be run heads up based on the competition classes. Each driver / rider nominates his or her competition class upon entering an event. If during official qualifying the driver / rider records two or more runs quicker than minimum ET of the class nominated, the competitor will be automatically moved into the faster class.
DB 11	WHY ONE COMPETITOR LEAVES THE START LINE BEFORE ANOTHER?
	Let's say one competitor dialed in a 12.2, the other a 14.2. If they are matched against each other in a handicap start race, the slower competitor will get a two second head start. This is built into the control of the Christmas tree by the Control Tower officials. If they each run according to their dial-in times, there should be a dead heat at the end. This of course, rarely happens as one competitor could go faster than his handicap and get disqualified, or one launches too early and receives a Red Light, or one has a better reaction time than his opponent.
DB 12	PENALTIES
	All penalties imposed by the Clerk of the Course under this article are subject to the competitor's right of protest to the Stewards of the Meeting, as per MSA GCR Part IX
	A competitor may be subject to penalties, including fines or exclusion, by the Clerk of the Course, subject to a hearing in terms of GCR 175
	12.1 Failing to report to the start line on time.
	12.2 Crossing the center line.
	12.3 A Red-Light start.
	12.4 Breaking out of his/her bracket.
	12.5 Failure to attend Driver's/Rider's Briefing.
	12.6 Depositing foreign matter including debris or oil onto the strip or staging lanes, except in the case where an accident has occurred.
	12.7 Unsportsmanlike behavior.
	12.8 Behavior that causes a safety hazard to other competitors and/or spectators.
	12.9 Driving dangerously. (This includes crew vehicles).
	12.10 Driving excessively fast on the 'return road' and pit area. This includes crew vehicles. (Speed limit 30Km/h)
	12.11 Behaving in a manner that could prejudice MSA.
	12.12 Disregarding a specific instruction from an official.
	12.13 Starting the run before the "Amber Light" sequence has started.
	12.14 Failing to report to the Race Control in respect of a vehicle breakdown before the start of main racing.
	12.15 Failure to sign attendance register after drivers/riders briefing.
	12.16 Driver/rider leaving car/bike unattended in the pit lanes or Line-up area.
	12.17 Depositing foreign matter including debris or oil onto the strip, staging lanes or pits, except in the case where an accident has occurred.

	12.18	Being suspected or seen to be consuming alcohol, regardless of the amount before or during the event. (Alcohol tests may be requested by Officials as/when required to do so.) (Refer to GCR118 and GCR122.vii, GCR 282 and MSA Anti-Doping Code)
DB13	THE TIMING EQUIPMENT	
	13.1	<p>This has been constructed to ensure reaction and elapsed times to a thousandth of a second and terminal speed to a tenth of a KPH. The start will be by light sequence provided by Christmas tree format with the following specifications:</p> <ul style="list-style-type: none"> - Approach - Pre-stage - Stage - Countdown - Go - Red Light <p>Approach, pre-stage, and track lights are controlled by the vehicle. Once in stage, the countdown will start, will start running down from 30 seconds. If the countdown has begun and the adjacent lane has not staged, the sequence lights will commence running down. The standard sequence will be 3 AMBER LIGHTS with a variable delay of between 0.3 and 0.5 seconds between lights.</p> <p>GREEN IS FOR GO! A Red light is caused by either rolling forwards from stage during the sequence lights. This is referred to as "Amber Gambling", i.e., trying to leave the line too early. However, when a Red Light is displayed, the run must be completed. THERE IS NO RECALL ON RED LIGHT, JUMP START OR FAILURE TO LEAVE ON THE GREEN LIGHT.</p>
	13.2	MSA drag racing rules do not permit rolling starts. To lay claim to any recorded time, the organiser(s) must comply with the rule.
DB14	DRAG RACING DISTANCE	
	All street racing venues, MUST run 1/8 mile. On application venues who wish to run longer distances will be considered, considering elements of safety and track conditions and design. All circuit racing venues can be run either on 1/8 mile or ¼ mile. MSA reserve the right to restrict circuit racing venues to a 1/8 mile if stopping distances, width and the condition of fences or barriers poses a safety risk.	

CLUB AND REGIONAL CHAMPIONSHIP DRAG RACING CATEGORIES AND CLASSES

INTERPRETATION OF REGULATIONS AND SPECIFICATIONS

In interpreting Motorsport regulations and specifications "what is not specifically permitted is disallowed" is the normal concept in keeping with the French regulations on which all motor sporting regulations are based. (Refer GCR 226)

CONTROLLERS OF THE CHAMPIONSHIP

The Controllers of the Championship will be the MSA Drag Racing Working Group, under the authority of Motorsport South Africa and in compliance with the MSA General Competition Rules and these Standing Supplementary Regulations.

- A. Championship and Challenge competitions will be based on Elapsed Time (ET) classes. These classes will have a minimum and maximum permissible ET. Vehicles on the other hand will fall into a category, which will govern the applicable construction and safety requirements of that vehicle. Therefore, vehicles from multiple categories will be permitted to enter any Championship and will compete in classes based on the ET run during dial-in / qualifying sessions.
- B. The following Regional Championships, can be run under approved SSRs:

Regional Championships

- ☞ Eastern Province (EP) - Regional Drag Racing Championship
- Kwa-Zulu Natal (KZN) - Regional Drag Racing Championship
- Gauteng (GP) – Regional Drag Racing Championship
- ☞ Western Province (WP) – Regional Drag Racing Championship

Any MSA Affiliated club or promoter can organise and run a Club Championship, by compiling a set of SSRs which must be submitted to MSA for approval.

Please note that all competitors wanting to participate in any, Regional and Club Championship must be in possession of the appropriate and valid Motorsport South Africa Drag Racing Competition Licence.

C. Each venue hosting events for, Regional and Club Championships must have timing equipment suitable for 1/8 mile and ¼ mile racing in order for these categories to work. It is optional for the venue to have timing equipment capable timing handicap style racing.

D. Any MSA affiliated organisation can apply for approval via the respective MSA Drag Racing Working Group or relevant Regional Committee to host Regional and/or Club Drag Racing Championships. The competitions will have to be run under the standardised Regional and Club Championship Standing Supplementary Regulations. At any given time only one affiliated club/organisation per MSA Region may host or convene a Regional Championship. The aforementioned club/organization may elect to host the Regional Championship at multiple MSA accredited circuits of their choosing, subject to approval by the MSA Drag Racing Working Group and relevant MSA Regional Committee.

1. MINIMUM ROUNDS AND STARTERS CARS AND BIKES

With reference to GCR 230 of the MSA GCRs the following criteria will apply in respect of the Championship categories.

- 1.1 All MSA Regional and Club Drag Racing Championships for cars and motorcycles will consist of a minimum of four (4) rounds and six (6) starters per class each, with all events to count, subject to meeting the minimum requirements.
- 1.2 For Regional and Club Championships, refer to the relevant Regional and Club SSRs.
- 1.3 To be classified as a finisher, the competitor must have:
 - Completed official qualifying
 - Completed the elimination rounds of the respective Championship irrespective of whether the competitor finished in the points position or
 - Completed at least three (3) timed runs in a Championship based on best ET. Jump starts (JS) and Did Not Finish (DNF) timed runs are not regarded as a completed / finished run.
- 1.4 To be classified as a class or overall Championship winner, the competitor must have participated in at least fifty percent (50%) of the events of the respective, Regional and Club Championships.

1.4.1 Vehicle Substitutions – In all, Regional and Club Championships

A competitor is allowed a vehicle substitution at an event on the following terms and conditions:

- i. Up to the end of qualifying
- ii. The competitor must apply with the Stewards, for a vehicle substitution
- iii. The substituted vehicle must be scrutineered and passed by the Scrutineer prior to be allowed to participate
- iv. A vehicle cannot be substituted at an event after the completion of qualifying i.e., a competitor cannot pass scrutineering or participate in official qualifying, have a vehicle problem, and then apply for a substitution.
- v. Vehicle substitutions will only be considered if the vehicle that was used at the event was damaged or broken to an extent that it is no longer safe to operate or cannot be practically repaired prior to the completion of official qualifying.
- vi. The substituted vehicle must compete in the same class as the original vehicle
- vii. All previous event times for vehicles to be replaced are voided and vehicle may be restricted
- viii. Changes must be made and driver / rider must enter and re-qualify during the normal schedule as posted for the event provided the vehicle is suitable for class as the one that is replaced
- ix. Qualifying run points will only be awarded for number of runs done with replacement vehicle and ranking points awarded for E.T.'s recorded with the replacement vehicle

2. CLASSES

2.1 Cars

Competition Classes are purely for grouping vehicles into a bracket for competition purposes. These classes have no bearing in terms of the safety features required in a vehicle. For example, you can have a True Street Car and a Modified Car compete in class J (ET between 13.000 – 13.999 seconds). The safety equipment required for the modified car will be different to those of the street car.

2.1.1 Competition Format A – Time Brackets No Handicap - Any Car with a Quarter (¼) Mile

Class	Designation	ET ¼ mile	Max Allowed Handicap
Extreme Drag	ED	7.000 - 7.499 seconds	HEADS UP ONLY
Ultra Drag	UD	7.500 – 7.999 seconds	HEADS UP ONLY
Pro Competition	PC	8.000 – 8.499 seconds	HEADS UP ONLY
Super Competition	SC	8.500 – 8.999 seconds	HEADS UP ONLY

Pro Street A	PSA	9.000 – 9.499 seconds	HEADS UP ONLY
Pro Street B	PSB	9.500 – 9.999 seconds	HEADS UP ONLY
Pro Street C	PSC	10.000 – 10.499 seconds	HEADS UP ONLY
Super Street A	SSA	10.500 – 10.999 seconds	HEADS UP ONLY
Super Street B	SSB	11.000 – 11.499 seconds	HEADS UP ONLY
Super Street C	SSC	11.500 – 11.999 seconds	HEADS UP ONLY
Sportsman A	SMA	12.000 – 12.499 seconds	HEADS UP ONLY
Sportsman B	SMA	12.500 – 12.999 seconds	HEADS UP ONLY
Sportsman C	SMB	13.000 – 13.500 seconds	HEADS UP ONLY

2.1.2 Competition Format B – Time Brackets with Handicap - Any Car with a Quarter (¼) Mile ET

Class	Designation	ET ¼ mile	Max Allowed Handicap
Extreme Drag	ED	6.600 – 7.499 seconds	0.500 seconds
Ultra Drag	UD	7.500 – 8.499 seconds	0.750 seconds
Pro Competition	PC	8.250 – 9.500 seconds	1.000 seconds
Super Competition	SC	9.250 – 11.000 seconds	1.250 seconds
Pro Street	PS	8.500 – 10.000 seconds	1.000 seconds
Super Street	SS	9.750 – 11.500 seconds	1.250 seconds
Sportsman	SM	11.000 – 14.500 seconds	1.500 seconds

2.1.3 Competition Format A – Time Brackets No Handicap Any Car with an Eighth (1/8) Mile ET

Class	Designation	ET ¼ mile	ET 1/8 Mile
Extreme Drag	ED	7.000 - 7.499 seconds	4.370 – 4.690 seconds
Ultra Drag	UD	7.500 – 7.999 seconds	4.690 – 5.020 seconds
Pro Competition	PC	8.000 – 8.499 seconds	5.020 – 5.350 seconds
Super Competition	SC	8.500 – 8.999 seconds	5.351 – 5.670 seconds
Pro Street	PS	9.000 – 9.499 seconds	5.671 – 6.000 seconds
Super Street	SS	9.500 – 9.999 seconds	6.001 – 6.330 seconds

**If the circuit is not suitable, the following classes of vehicles will be restricted to solo runs over a quarter (1/4) mile and can only race heads-up over an eighth (1/8) mile. The determination of whether vehicles in class SS – ED will run heads up or solo over an eighth (1/8) and quarter (1/4) mile will be made by the respective circuit based on the ET above and terminal/exit speed of the vehicle and specified in the respective, regional or club SSRs. These determinations are subject to approval by the MSA Safety Panel.

*** All grade B and C and D drag racing venues or street venues will limit all vehicles depending on the venue as prescribed by the Safety Panel after venue inspections and consultation with the MSA Drag Racing Working Group and MSA ManCom. The above permission may be changed at any time during the season should the MSA Safety Panel deem the venue unsafe on a matter.

2.2 Bikes

2.2.1 Competition Format A – Time Brackets No Handicap - Any Bike with a Quarter (¼) Mile ET

Class	Designation	ET ¼ mile	Max Allowed Handicap
Ultra Bike	UB	7.500 – 9.000 seconds	HEADS UP ONLY

2.2.2 Competition Format B – Time Brackets with Handicap - Any Bike with a Quarter (¼) Mile ET

Class	ET ¼ Mile	Dial In	Maximum Allowed Handicap
Pro Bike	PB	7.500 – 9.000 seconds	1.500 seconds
Street Bike	SB	8.800 – 11.000 seconds	2.000 seconds

2.3 Dial Ins – Competition Format B

Class Car	Minimum	Maximum
Extreme Drag	6.600 seconds	7.499 seconds
Ultra Drag	7.500 seconds	8.499 seconds
Pro Competition	8.250 seconds	9.500 seconds
Super Competition	9.250 seconds	11.000 seconds
Pro Street	8.500 seconds	10.000 seconds
Super Street	9.750 seconds	11.500 seconds
Sportsman	11.000 seconds	14.500 seconds
Class Bike	Minimum	Maximum
Ultra Bike	7.500 seconds	9.000 seconds
Pro Bike	7.500 seconds	9.000 seconds
Street Bikes	8.800 seconds	11.000 seconds

2.3.1. Note for safety reasons and excessive speeds attained, maximum handicap will apply as follow:

2.3.2. The quickest vehicle's dial-in will be accepted and slowest vehicle in the category may not dial-in slower than 0.5 second from quickest dial-in time.

- Extreme Drag – A maximum handicap of 0.500 second will be applied.
- Ultra Drag - A maximum handicap of 0.750 second will be applied.
- Pro Comp - A maximum handicap of 1.000 second will be applied.
- Super Comp - A maximum handicap of 1.250 seconds will be applied.
- Pro Street - A maximum handicap of 1.000 seconds will be applied.
- Super Street A - A maximum handicap of 1.250 seconds will be applied.
- Sportsman - A maximum handicap of 1.500 seconds will be applied.
- Pro Bike - A maximum handicap of 1.500 seconds will be applied.
- Street Bike - A maximum handicap of 2.000 seconds will be applied.

2.3.3. Competitors are allowed to dial a Maximum time of 1% slower than their best qualifying run.(No limit for dialling quicker)

2.3.4. Maximum time of 30 minutes in each class will be allowed for dial-in times to be entered by all competitors after their final qualifying run in that specific category. Failure to do so will result in a competitor being dialled in automatically by 1% quicker than their best qualifying run.

3. CAR CATEGORIES

3.1 The following are car categories for Regional and Club Championships events to be held at venues graded and approved for Regional and Club Championship events.

Vehicle categories will have no bearing or limitation in terms of the class that a vehicle will be permitted to compete in. Vehicle categories will only be used to impose the minimum safety requirements. For example, a Pro Street Category vehicle can run in the same class as a Altered Car Category vehicle, i.e. ET between 13.000 – 15.999 but the vehicle safety requirements for the altered-vehicle and Pro Street vehicle will vary as per the category requirements. ET and exit speed of a vehicle irrespective of class will determine the requirement for a parachute as per CR53.

3.1.1 Cars

Category	Designation
Pro Street	<p>This category will apply to all foreign and domestic Original Equipment Manufacturer (OEM) production type automobiles, and SUVs and LDVs. All vehicles must be street driven and drivers must carry a valid South African vehicle registration and licensing certificate (disc). For a vehicle to be categorized in the Pro Street Car Category, the vehicle must pass all stipulations of the South African National Road Traffic Act 93 of 1996 and retain all OEM safety features, therefore making it legal to operate on a public road.</p> <p>The Pro Street Category makes provision for all fully OEM cars and cars with bolt on modifications, provided that no cutting or sectioning of the chassis is done</p>

	<p>This category will restrict the Elapsed Time (ET) of participating true street vehicles as follows:</p> <ul style="list-style-type: none"> - 2014 – Current OEM model-year production (EURO NCAP 5 RATED) enclosed vehicles are permitted to run no quicker than 9.000 second-quarter mile (*5.65 eighth mile) and/or faster than 240 kph, without the need for a roll-cage. - 2008 – 2013 OEM model-year production (EURO NCAP 5 RATED) enclosed vehicles are permitted to run no quicker than a 10.000 second-quarter mile (*6.40 eighth mile) and/or no faster than 216 kph, without the need for a roll-cage. - Pre 2008 OEM model-year production enclosed vehicles are permitted to run no quicker than a 12.000 second-quarter mile (*7.70 eighth mile) and/or no faster than 190 kph, without the need for a roll-cage. - Convertibles quicker than 13.499 seconds-quarter mile (*8.25 eighth mile) and T-tops quicker than a 11.499 second-quarter mile (*7.35 eighth mile) must meet the rollbar and roll-cage requirements. <p>All vehicles older than 2008 irrespective of whether they are in full OEM trim or not that are capable of running quicker than 12.000 second-quarter mile (*7.70 eighth mile) and/or faster than 190 kph, must have a full roll cage installed.</p>
Altered Car	<p>This category will apply to all four wheeled cars altered / modified for drag racing. Where a vehicle has been cut or sectioned, this will be considered as altered.</p> <p>For altered / modified production bodies the basic standard appearance is maintained, engine, driveline, chassis etc., may be altered, modified, as outlined in the category requirements. These vehicles would typically not be able to pass all stipulations of the South African National Road Traffic Act 93 of 1996 and would not retain all OEM safety features, thus would not be legal to drive on a public road.</p>

3. BIKES CATEGORIES

4.1 The following are bike categories for Regional and Club Championship events to be held at venues graded and approved for Regional and Club Championship events.

4.1.1 Motorcycles

Category	Designation
Street Bikes	<p>This category will apply to all foreign and domestic Original Equipment Manufacturer (OEM) production type motorcycles. All motorcycles must be street driven and riders must carry a valid South African vehicle registration and licensing certificate (disc). For a motorcycle to be categorized in the Street Bike Category, the motorcycle must pass all stipulations of the South African National Road Traffic Act 93 of 1996 and retain all OEM safety features, therefore making it legal to operate on a public road.</p>
Pro Bikes	<p>This category will apply to all two wheeled moderately, and highly modified production model vehicles and professionally modified vehicles designed only for drag racing. For modified production bodies the basic standard appearance is maintained, engine, driveline, chassis etc., may be altered, modified, as outlined in the category requirements. These motorcycles would typically not be able to pass all stipulations of the South African National Road Traffic Act 93 of 1996 and would not retain all OEM safety features, thus would not be legal to drive on a public road.</p>

CHAMPIONSHIP FORMAT AND POINT SCORING

All Championships / Competitions / Challenges will award points to competitors finishing 1st to 4th in all of the respective classes.

1. CHAMPIONSHIP FORMAT

Regional and Club Championships will comprise of a minimum four (4) events / rounds.

Each event / round will consist of 6 sessions:

- 2 x Qualifying sessions
- 4 x Competition sessions

Competition Format A (Time Brackets No Handicap)

Session 1 – Qualifying – Heads-up per class

Session 2 – Qualifying – Heads-up per class

PAIRING – Competitors will be ranked by best ET from Session 1 and Session 2 using the Sportsman's ladder

Session 3 – Eliminations - Heads-up per class

PAIRING – Winners will advance to the next round. Based on the size of the field the appropriate sportsman's ladder will be used until 8 competitors remain.

Session 4 – Quarter Final – Heads Up Racing for top 8 winners of Session 3

PAIRING – Winners from Session 4 advance to the Semi-Final

Session 5 – Semi-Final – Heads Up Racing for top 4 winners of Session 4

PAIRING – Winners from Session 5 advance to the Final and Losers from Session 5 will compete for 3rd place

Session 6 – Finals – Heads Up Racing for top 2 winners of Session 5 for 1st and 2nd place and losing semi-finalists for 3rd place

Competition Format B (Time Brackets With Handicap)

Session 1 – Qualifying – Heads-up per class

Session 2 – Qualifying – Heads-up per class

PAIRING – Competitors will be ranked by best ET from Session 1 and Session 2 (Even field). All odd numbers out

Session 3 – Eliminations – HANDICAP racing for ALL Qualifiers evenly paired

PAIRING – Winners from Session 3 (6 / 8 (max) competitors advances to session 4)

Or Winners from Session 3 (TOP 4 competitors advances to session 5)

Session 4 – Quarter Final – HANDICAP racing for top 6/8 winners of Session 3

PAIRING – Winners from Session 3 or 4 (TOP 4)

Session 5 – Semi-Final – HANDICAP racing top 4 ALL CLASSES

PAIRING – Winners from Session 5 together for 1st and 2nd PLACE , Losers from Session 5 together for 3rd PLACE

Session 6 – Finals – HANDICAP racing for TOP 3 IN CLASS

2. AWARDING OF POINTS

Points will be awarded from 1st place to 4th place. When points are awarded from 1st to 4th place it will be in any Championship or competition when eliminations are done, i.e. quarter finals, semifinals and a final, points will be awarded from 1st to 4th.

In all Regional and Club Championships using elimination rounds to determine a winner in the respective class, points will be awarded as follows:

Semi-final and Finals Points

In the Semi-final and finals of each round, the winning competitor in each class will score 25 points, 2nd place 20 points, 3rd place 15 points and 4th place 10 points.

Position/Place	Points
1 st Place	25
2 nd Place	20
3 rd Place	15
4 th Place	10

The winner of the final will finish in 1st place, and the losing finalist will finish in 2nd place. The two losing semi-finalists will race heads up to determine 3rd and 4th place. The winner of this tie will finish 3rd, and the loser will finish in 4th position/place.

2.1 Bonus Points

As an incentive to grow participation in regional events, participation points will be awarded as follows:

2.1.1 Attendance Points - 5 (Five) attendance points will be awarded for a competitor that has attempted to start a run and/or burnout in the burnout box in the qualifying session

2.1.2 Completed Qualifying Run Points – Points will be awarded for each completed qualifying run, without penalty:

Qualifying Runs	Points
1 Run	1
2 or more Runs	3

2.1.3. Qualifying Ranking Points

Qualifying Ranking	Points	Qualifying Ranking
Top Qualifier	8	Top Qualifier
2 nd Qualifier	7	2 nd Qualifier
3 rd Qualifier	6	3 rd Qualifier
4 th Qualifier	5	4 th Qualifier
5 th and 6 th Qualifier	4	5 th and 6 th Qualifier
7 th and 8 th Qualifier	3	7 th and 8 th Qualifier
9 th to 12 th Qualifier	2	9 th to 12 th Qualifier
13 th to 16 th Qualifier	1	13 th to 16 th Qualifier

2.1.4 Elimination Session Points

Elimination Points	Points
First elimination session losers, without penalty	5

Second elimination session losers, without penalty	8
--	---

Illustration / example of points:

The maximum number of points awarded for a single round in the Regional and Club Championships will be as follows:

Event Points Breakdown	Points
Attendance Points	5
Completed Qualifying Runs (all sessions) Points	3
Qualifying Ranking Points (top qualifier)	8
1 st Place Points	25
Total Points Awarded	41

**NO Points will be awarded for a “No Show” in the Elimination Rounds.

***Points will be awarded for “Breakdown” losers, but the vehicle must have appeared in the Pre-Race Line-Up area.

3. REGIONAL AND CLUB CHAMPIONS AND CLASS WINNERS

- I. Competitors will accumulate points from each round of the Regional or Club Championships in the respective classes that they participate in. A competitor can accumulate points in multiple classes in the season. If the competitor competes in multiple classes over the season the points will not be added together. Points attained in different classes will be recorded separately but not added together.
- II. The competitor with the most points in a specific class at the end of the season will be deemed the overall winner of the class, the competitor with the second most points and third most points will be placed second (2nd) and third (3rd) in class respectively. 4th
- III. In case of a draw at the end of the final round of the Championship, the following will apply:
 - o Most Event Wins
 - o IF (i) above still equal, Most Runner-Up wins
 - o IF (ii) above still equal, Most 3rd place wins

3.1.1 Regional and Club Champions will be declared as follows:

Cars

- o Regional /Club Champion – Extreme Drag (ED)
- o Regional /Club Champion – Ultra Drag (UD)
- o Regional /Club Champion – Pro Competition (PC)
- o Regional /Club Champion – Super Competition (SC)
- o Regional /Club Champion – Super Street (SS)
- o Regional /Club Champion – Sportsman (SM)

Motorcycles

- o Regional /Club Champion - Ultra Bike (UB)
- o Regional /Club Champion - Pro Bike (PB)
- o Regional /Club Champion - Street Bike (SB)

- In determining the Regional and Club Champions the competitor with the most points in the respective class will be declared the Champion.
- The minimum number of starters in a class will be six (6) vehicles. If there are less than six (6) vehicles in any specific class, that class will not qualify for a Regional Championship but will qualify for class winners.

2.1.3 Number of Events to Count

In terms of GCR 234 (ii) “For the Championship to be concluded and Regional Champions declared, at least 50% (rounded up) plus one of the events originally inscribed on the respective regional calendars must have taken place and been scored”

Therefore in the context of the Regional Championship should less than three (3) rounds be held and scored of any of the Regional Championships during the season, the Championship, may be declared null and void by the Controllers.

4. MULTIPLE ENTRIES

A competitor may not enter more than one vehicle in any Championship or competition, in the same class

5. MINIMUM CRITERIA OF AWARDING A ROUND LOSER

Will be if both competitors appeared on the line with their vehicles and were able to take the light under their own power, and / or vehicles breaking down during start-up to approach the start line / burnout area.

6. SEPARATION OF TIES

If at the conclusion of the season if a tie exists (for the top 3), it shall be resolved as follows. If after step one is followed a tie still remains, additional steps are to be followed until a tie is broken:

6.1 Driver / Rider with most event (with same status where tie exists) wins. (Depending in which class the points are tied.)

6.2 Driver / Rider with most Runner-ups (with same status where tie exists) finishes. (Depending in which class the points are tied.)

6.3 Driver / Rider with most 3rd place (with same status where tie exists) finishes. (Depending in which class the points are tied.)

6.4. Should the tie still exist, the driver / rider with the best overall reaction time for the season. (Depending in which class the points are tied.)

6.5 Should the tie still exist, the driver / rider with the best average reaction time, calculated by averaging the driver's / rider's best reaction time from each round that wins the title. (Depending in which class the points are tied.)

7. EVENT CANCELLATIONS (RAIN AND/OR OTHER REASONS)

7.1 Should it so happen that any event is cancelled completely, no points will be awarded to any competitor.

7.2 Should an event be started and not be completed and without running on a Re-Scheduled rain date, each category will score points up to successful completion of an elimination round by all competitors in each individual category. (Re: some categories may have progressed further than other categories.)

7.3 Should any event get Re-Scheduled to a "Rain Date"; no points will be awarded to any competitor for the date that gets Re-Scheduled. Points will only be awarded for the Re-Scheduled event on the rain date.

DRAG RACING RULES, REGULATIONS AND SPECIFICATIONS

DR 1 VEHICLES – GENERAL

- 1.1 All vehicles must satisfy the Scrutineers of the meetings as to their suitability for Racing, considering all details of their design and construction. In addition, it must be evident, both from a static examination from its behavior on the track, that a vehicle will present no hazard to the driver / rider or to the other competitors or to spectators.
- 1.2 **Appearance:** Vehicles participating in Drag Racing events must be presentable in appearance at all times. At any sanctioned event, the Scrutineers may reject vehicles that are considered improperly prepared.
- 1.3 The appearance of personnel attending contestant vehicles is equally important and each member of a participant crew must be fully attired including shoes when present in the staging, starting and competition areas of the racetrack. It is the Chief Start Line Marshal's responsibility to police the appearance of crewmembers that venture into the abovementioned areas.
- 1.4 **Component Substitution:** Any component of a vehicle may be replaced (except the chassis) during competition provided that the new components are inspected and passed by the scrutineer if liable to alter that vehicle's class or affect its safety. The onus is on the competitor to be ready on time for each run. The vehicle must still comply with regulations of its originally entered class at that event.

- 1.5 **Ground Clearance:** All vehicles competing are required to maintain a minimum of 75mm ground clearance, measured from the front of the vehicle to 300mm behind the center line of front axle and 50mm for the remainder of the car. Wheelie bars are exempt. All vehicles will be checked for correct ground clearance during scrutineering. Subsequently, any staging problems should be the fault of the start line equipment and if a problem occurs, both vehicles should be backed out and the fault investigated. If the fault is found to be with one of the vehicles, it will be excluded immediately.
- 1.6 **Front Overhang:** The maximum front overhang, measured from the center of the front axle to the furthest edge of the front bumper, inclusive of any extension plates (see note below), spoilers, lips, etc. Modified, Funny cars, Dragsters, Competition Altered, and all other open wheeled vehicles (cars) will have a maximum of 40" (1016mm) and all door cars 45" (1143mm)
NOTE: Extension plate will be permitted and have a maximum length of 4" (102mm). Extension plates must form part of the bumper/body, it must be of a permanent nature (RE: Not easily removable or interchangeable), non-adjustable and have a rigid construction preventing flex.
- a) Front end body/fenders may be extended on Altered class only.
 - b) Extension plates allowed on Altered and Pro Street class cars only.

DR 2 RACING: GENERAL REGULATIONS APPLICABLE TO ALL COMPETITORS

- 2.1 In the interest of safety, before a vehicle proceeds onto the strip, a check shall be made that the scrutineers have passed it.
- 2.2 Only the entrant shall drive a vehicle onto the strip during pre-race practice and the racing, except with the specific permission of the Clerk of the Course.
- 2.3 No vehicle may be driven or pushed in any direction, other than in the direction of the course, either during unofficial or official practice sessions or during a race meeting. Vehicles may be reversed (backed up) after a burnout.
- 2.4 Any driver / rider stopping on the strip or its verges, whether voluntarily or involuntarily (such as through stalling the vehicle), shall remain there until it is safe to move as directed by an official.
- 2.5 Any driver / rider who refuses to voluntarily reduce speed or stop in the event of his/her vehicle not handling properly (i.e., excessive drifting of the vehicle towards the centre or edge of the track), or any driver/rider who "fishtails" or weaves with undue regard to the safety of himself/herself, other competitors and/or spectators renders himself/herself liable to disciplinary action.
- 2.6 If any vehicle at any event spills a foreign substance on the track, that requires clean-up and takes longer than 15 minutes, the competitor will be liable for a fine of R2500-00. If the delay is 1 hour and longer or the track is closed, a fine of R5000-00 will be imposed on the competitor.

DR 3 BURNOUTS

- 3.1 A maximum of two burnouts is allowed. Only vehicles equipped with racing slick-type Tyres are permitted to cross the start line. Maximum time for this will be two minutes, of which the period starts when the first burnout to be performed by either competitor commences.
- 3.2 At the end of the two-minute period or once a vehicle is staged, the remaining vehicle will have a maximum of 30 seconds to stage. It will be the Chief Start line Marshal's responsibility to enforce these requirements unless by prior arrangement with the parties involved.
- 3.3 Burnouts must be of an UNASSISTED NATURE, i.e., no holding of vehicles under any circumstances at any track. It will be the Chief Start line Marshal's responsibility to police the burnout procedure and to halt any handling of vehicles.
- 3.4 Crossing the centre line during a burnout is not an automatic exclusion unless such action is deemed by the start line officials to be careless or hazardous to the vehicle in the opposite lane.

DR 4 ALTERNATES

- 4.1 In order to ensure paired competition during all elimination series, the following rules shall apply. Where an elimination bracket needs to be filled, an alternate or alternates shall be drawn from non-qualifiers in order of their qualifying times. The use of alternates is restricted to the first round of Racing, and no substitutes will be brought in after the first round of racing.
- 4.2 If an elimination contestant is unable to complete the following round, they must notify race control as soon as possible so that seeding sheets can be adjusted accordingly and ensure paired runs continue.

DR 5 STAGING

- 5.1 Once a vehicle reaches the front of the staging lanes for a run it must be prepared to fire and race. The onus is on the competitor to make sure both he and his opponent are ready for each new run. If a competitor is on the start line and his opponent does not appear within the prescribed two minutes that competitor must then make use of the 30-second rule.
- 5.2 If a competitor notifies both his opponent and race control that he is not ready, the pairing can be slotted in at the bottom of the present elimination's round. However, if all races have been completed in the respective elimination round, a bye run, directly after the last pairing is required by the racer who is ready, and his missing opponent is eliminated.

- 5.3 In order to be a legitimate race winner, a contestant's vehicle must start and self-stage. This rule also applies to BYE runs. It is not allowed to push start a vehicle or to push stage a vehicle. Staging must be done under the vehicle's own engine power in the direction of the Racing.

DR 6 THE DIFFERENCE BETWEEN BYE RUNS AND SOLO RUNS

- 6.1 Bye runs
- (a) Bye runs are compulsory and are awarded in progressive order, e.g., if a field produces three Bye runs, the Top Qualifier will receive the first Bye, the No. 2, the second, and the No. 3, the third. On an uneven field, the Top Qualifier always receives a Bye run.
 - (b) The breakout rule does not apply during a Bye Run.
 - (c) A driver/rider that gets a red light with any Bye Run will be excluded, however, if a situation arises where there are three competitors in a semi-final and the competitor that has the Bye-Run awarded for that round of competition gets a Red Light, he will be awarded 2nd Place and the winner of the other run in the same semi-final will be awarded 1st Place and the loser of the same run, 3rd Place.
 - (d) If a competitor crosses the boundary line on a Bye-Run run, the elapsed time is voided for lane choice determination.
- 6.2 Solo Runs
- (a) If one competitor fails to report to the start line, the other competitor will perform a solo run. This is not a Bye Run; merely the result of a "no show" and the breakout and red-light rule will apply.
 - (b) If a competitor crosses the boundary line on a solo run, the elapsed time is voided for lane choice determination.
- 6.3 No Shows
- The onus is on the competitors to ensure they are ready for each new run. If a competitor is on the start line and his opponent does not appear within the prescribed two minutes, that competitor must then make use of the 30-second board.
- 6.4 Crossing the Centre Line
- (a) In case of any competition (not qualifying) run and two vehicles competing, crossing the centre line will result in immediate disqualification. If both crosses the centre line, the 1st or worst rule applies
 - (b) During a BYE or SOLO run, crossing the centre line does not constitute an infraction or elimination from competition.
 - (c) During a BYE run or SOLO run and crossing the centre line will be subject to the following:
 - o Competitor is to correct the vehicle and revert back to and complete the run at finish line in the same lane as run was started.
 - o Elapsed time is voided for lane choice determination for next round of competition.
- It should be noted that during a BYE or SOLO run, crossing the centre line does not constitute an infraction. However, if this occurs, i.e., if the competitor started out in the left-hand lane and crosses the centre line, the competitor must correct the vehicle and revert back to and complete the run in the left-hand lane before the finish line. In qualifying, crossing or touching the centre line, the run becomes null and void
- 6.5 Re-runs
- (a) A Re-run will only be awarded to a competitor in extreme circumstances such as timing equipment malfunction and/or race control error and/or if time permits and/or foul by opponent resulting in no result on the same run
 - (b) The Clerk of the Course reserves the right to issue a re-run to 2 (two) competitors in the event of a race control error or equipment malfunction due to various reasons, i.e. power failures, etc.
 - (c) If a dial-in error was made by the Tower and was the cause of the competitor losing with the incorrect dial-in time, both competitors can agree on a re-run, or if both competitors don't agree to a re-run, the winner will be determined by means of a calculation, utilizing correct dial-in times, the difference in handicap, the reaction times and the ET's to establish who was first over the line.
 - (d) A re-run/calculation will only be agreed to if the competitor concerned has reported the error immediately after the run, before the field progresses to the next round.

DR 7 BREAKOUT RULE

- 7.1 To prevent competitors from nominating a “soft” dial-in time and then running quicker in competition, a breakout rule is enforced which eliminates a racer running below their nomination. If both competitor’s breakout the racer who infringes by the largest margin is the loser and the one who infringes by the least is the winner. Points/remuneration will be allotted as if both competitors legitimately won/lost the race concerned.

DR 8 EXCLUSION – EXAMPLES OF GROUNDS FOR EXCLUSION

If a driver / rider is excluded for any reason, he/she cannot be reinstated at any time during the event and will only gain points/remuneration up until the round of exclusion.

8.1 “First” or “Worst” Rule

The ideal outcome of any race is to have one winner and one loser. In cases where both competitors are guilty of an infraction during the same elimination race, the ‘First or Worst’ rule will apply. This rule applies in all circumstances such as in the case where competitor red lights, then their opponent break out. The red light would be classified as the worst infraction.

The ‘First’ ruling applies when both competitors are guilty of an equal/same infraction. The ‘First’ offender will be excluded. (This ruling does not apply to breakouts - Refer to breakout rule – DR 7.)

The ‘Worst’ ruling applies when both competitors are guilty of a different infraction, then the following order of infractions will apply. The ‘Worst’ offender will be excluded, starting from Number 8.1.1.

Order of Infraction:

- 8.1.1 Failing to report to the Start line on time.
- 8.1.2 Failing to stage the vehicle
- 8.1.3 Starting the run before the “Amber Light” sequence has started. (Refer to DB 3.1.4)
- 8.1.4 Crossing or touching the strip centre or boundary lines other than leaving the strip intentionally. (In all instances the run is to be aborted and no E.T. or speed will be recorded).
- 8.1.5 A red light start
- 8.1.6 Failure to complete the run.
- 8.1.7 Breaking out of the dial-in nomination where applicable.

DR 9 PASSENGERS

A passenger may be carried in a Drag Racing vehicle, for exhibition purposes only, subject to the following conditions:

- 9.1 Approval shall be at the discretion of the Clerk of the Course.
- 9.2 The vehicle must be of a sedan (or truck) type nature.
- 9.3 The passenger must sign a form indemnifying the respective track and MSA from any misfortune.
- 9.4 The passenger must be afforded the same measure of protection as is afforded the driver for the class of vehicle in question, i.e., helmet, driving suit, multi-point harness, seat, etc.
- 9.5 Restricted to solo passes only.

DR10 PROTESTS AND APPEALS

Refer to Part IX of the MSA GCRs

DR11 START PROCEDURE

- 11.1 Full Tree
 - 11.1.1 Approach, pre-stage, and stage lights are controlled by the racer’s vehicle.
 - 11.1.2 The standard arrangement of lights will be three amber lights, one green and a red light at the bottom of the Christmas tree.
 - 11.1.3 The timing sequence is variable from 0.3 seconds between lights to 0.5 seconds. This sequence is adjustable from the tower and once established at the start of official practice cannot be varied.
 - 11.1.4 The green light coming on is the signal to “GO”.
 - 11.1.5 A red light may be caused to light by either rolling forwards from the stage position during the start sequence of lights or trying to leave the line too early so as to gain an advantage on an opponent.
 - 11.1.6 This technique is usually referred to as “AMBER GAMBLING”. If a red light is shown in either lane, the race must be completed.
 - 11.1.7 There are no re-run-on red light starts.
- 11.2 Pro-Tree
 - 11.2.1 The call up, pre-stage and stage light operation remains the same.
 - 11.2.2 The start sequence is limited to one amber light and the green light start.
 - 11.2.3 The only allowable time sequence between lights is 0.4 seconds.
 - 11.2.4 This format is optional depending on the Drag meet organisers.
 - 11.2.5 If the meet organisers choose the Pro-tree for eliminators for the entire meeting, this fact must be made clearly known to the racers at the drivers / riders briefing.
- 11.3 Lane Choice
 - 11.3.1 It is not for Race Control to decide lane choice.
 - 11.3.2 Lane choice is determined by elapsed time. The driver / rider with the better qualifying position gets first-round lane choice, and in subsequent rounds, the lane choice goes to the driver / rider

with the lowest elapsed time (in relation to his/her dial in.) from the previous round. If there is a tie to the thousandth, speed is not the determining factor – the first contestant posting the time will take precedence.

DR12 NATIONAL DRAG RACING RECORDS

- 12.1 The standard of excellence of performance in South African Drag Racing is the National Record. In a sport where records play such a vital role, every effort will be made to maintain their accuracy and validity.
- 12.2 With major changes to class regulations for various categories taking effect on 1 January 2023, all present records held by vehicles fitting into the new classes will be carried over to the new class.
- 12.3 Elapsed Time records will be recorded to the thousandth of a second while Terminal Speed records will be recorded to the hundredth of a kilometer-per-hour.
- 12.4 If a lower class of the same type and aspiration has a National ET record quicker than its equivalent higher class, then those classes without a record or those with a slower ET record will become "Minimum's" utilizing the figure posted by the lower class (i.e. C/S ET record is quicker than B/S record), then the B/S ET record becomes a "minimum" using the same ET record set in C/S).
- 12.5 All competitors who officially set or break National Records, both Elapsed Times and Terminal Speeds, will be presented with a National Record Certificate. Once the record ratification has been finalised the National Record Certificate will be forwarded to the competitor's mailing address as well as held on file at the MSA Head Office.
- 12.6 Official National Drag Racing records may ONLY be set at National Championship status events classification events or meetings designated by MSA in writing as a record setting event provided that:
 - 12.6.1 The track has been accredited by MSA to host drag racing events.
 - 12.6.2 A MSA Official is in attendance.
 - 12.6.3 The competitor holds a current Drag Racing competition license.
 - 12.6.4 In order to ensure their validity, all new records must be backed up with another run within (1%) ONE PERCENT during the periods eligible for record setting at that event. A run that is faster or quicker but outside the one percent can be used as a backup for a record. The record then becomes the slower figure.
 - 12.6.5 Records may be set or broken during racing ONLY and until a driver/rider is eliminated from further competition. A competitor will be allowed to do one back-up run if he/she is eliminated from competition and if time permits it.
 - 12.6.6 Previous runs allowable as one-percent backup.
 - 12.6.7 Separate records will be recognized for ET and KPH performances.
 - 12.6.8 Records will only be issued in the class entered on the day, i.e., competitors may not enter in one class and claim a record in another.
 - 12.6.9 Before any backup run and immediately after a record setting performance, a fuel and weight check will be required as well as a cubic capacity certification after the vehicle's last run-in competition. Failure to report to the Clerk of the Course for post-race checks will be considered an admission of illegality and will be grounds for immediate exclusion from the event.
 - 12.6.11 Any vehicles running as exhibition vehicles (i.e., Top Fuel, Funny Car, Jet Dragster, etc.) will be awarded unofficial records only with one run being completed; however, official records may be claimed if a backup run is being made as per all other classes.
 - 12.6.12 Competitors who claim records must fill out forms.

TRACK AND SAFETY REGULATIONS

TR 1 TRACK REQUIREMENTS AND REGULATIONS

- 1.1 Permanent Facilities:

The plan of the strip is to be submitted to MSA when applying for a track inspection and shall be to a scale of not less than 1:500 and shall indicate position of:

 - 1.1.1 Start and Finish Lines
 - 1.1.2 All enclosures and entrances
 - 1.1.3 All protective Barriers
 - 1.1.4 Race Control
 - 1.1.5 Assembly for grid starts
 - 1.1.6 Type of surface
 - 1.1.7 Length of strip
 - 1.1.8 Grandstand
 - 1.1.9 Car parks for officials/competitors
 - 1.1.10 Entry to and exit from the Parc Ferme for technical inspections
 - 1.1.11 Width of track showing maximum and minimum

- 1.1.12 Ambulance positions
- 1.1.13 Scrutineering Bay / Weighing / Welding areas
- 1.1.14 Timekeepers and Lap scorers
- 1.1.15 Secretarial Control and Notice Boards
- 1.1.16 Toilet facilities
- 1.1.17 Refreshment areas
- 1.2 Obligatory Track Inspection and Installation
 - 1.2.1 All tracks will be inspected and approved by the Track Inspector appointed by the MSA Safety Panel, which will include a Medical and FACET Representative appointed by MSA.
 - 1.2.2 The timekeeping, scoring, public address, and secretarial areas to be covered.
 - 1.2.3 The paddock, weighing, scrutineering areas to be cemented surfaces or hard standing.
 - 1.2.4 Parking facilities for competitors and officials to be close to the track.
 - 1.2.5 Toilet facilities for males and females.
 - 1.2.6 Parc Ferme area to be capable of closure.
 - 1.2.7 Welding area away from paddock and any area where fuel is held.

TR 2 GRADING OF TRACK FACILITIES

2.1 GRADE A FACILITIES – FIA Homologated venues only

GRADE B FACILITIES

- 2.1.1 Timed Distance
Timed distance, from the Start Line to the Finish Line is 1320 feet (402.336 meters). The speed trap extends 20.13 meters either side of the Finish Line, to measure the Terminal speed of vehicles at that point. In some cases, the speed trap utilizes the 20.13m distance before the finish line.
- 2.1.2 Burnout
 - (a) A suitable area is required before the Start line for staging and pre-race preparations.
 - (b) This area where possible should be in direct line with the Racing surface and provide for vehicles up to ten meters in overall length.
- 2.1.3 Braking Area
 - (a) Primary: From the finish line the primary braking area should extend another 500m. These sections of the track should be the same width as the Racing surface.
 - (b) Emergency: In addition to the Primary braking area a further clear area of 300m should be available.
- 2.1.4 Surface
 - (a) Timed Distance
Smooth flat surface of recognized road base construction hot mix, concrete or approved sealed bitumen surface.
Shoulders and irregular joints are not permitted. All edges must be satisfactorily blended.
 - (b) Primary Braking Area:
Should be a continuation of the surface used for the Timed Distance but must comply at least with minimum specification for that.
 - (c) Emergency Braking:
Sealed surface.
 - (d) Width
The width of the track and braking area should not be less than 15.2m.
New facilities should not be less than 18.5m.
Should the Drag strip widen or narrow the transition should be made as gradually as possible (not less than 1:20)
- 2.1.5 Surface Tolerance
 - (a) The aim should be plus or minus a maximum of 6mm in any 10m distance, for the Time Distance and the Primary Braking Area.
- 2.1.6 Levels Variation
 - (a) Timed distance: Rise or fall should not exceed 1%.
 - (b) Primary Braking Area: A fall exceeding 1% from the Finish Line will require approval from MSA subject to any additional length being available.
 - (c) A rise is acceptable, but consideration should be given to exits so that delays in the clearing of the track may be avoided.
- 2.1.7 Crossfalls
 - (a) For drainage purposes, a one-way cross fall of no more than 1% of equivalent camber, is acceptable.
- 2.1.8 Return Road/Turnoffs
 - (a) The Return Road should be a minimum of 3 meters in width, with suitable access to Pit and Staging Lane areas. It should be sealed so that all vehicles may use it at all times.
- 2.1.9 Safety Barriers

- (a) Due to variations necessary through individual requirements, the following details are to be considered a general indication of what will be accepted.
 - (b) The primary crash barrier must be located between the track edge, and a point of no closer than 6.0m in front of the spectator fence. Track edge location is preferred. Crash barriers are mandatory for each side of the track or part thereof, where spectators are permitted.
- 2.1.10 Barrier Construction
Within two meters of the track edge.
- (a) Concrete wall as per the FIA Specifications for Drag Racing. This is the only barrier method permitted for a new venue being built from 2026 onwards.
- 2.1.11 Return Road Protection
- (a) Where a minimum of triple row Armco railing guardrail is located between the track edge and the return road.
 - (b) Otherwise, the return road must be at least 30 meters from the track edge, with some alternative approved line of protection.
- 2.1.12 Spectator Fence
All spectator and pit areas must be enclosed with a minimum 1.2 meters high fence of chain link construction. Security and/or fencing must be provided in any area of potential danger (Staging Lines, Braking Area) to prevent public access.
- (a) All public areas should be maintained to ensure a safe Environment for the general public.
 - (b) All spectator areas, including the pit area, must be separated from the restricted areas by fencing (minimum 1.2m in height). Positive barriers are further required where deemed necessary for reasonable protection of spectators and participants.
 - (c) All spectator areas, including the pit area, must be a minimum of 15.2m from positive barriers. If spectator areas are located down track more than 200m from the starting line, and if spectator areas are not a minimum of 15.2m from positive barriers, the track must have a debris fence in this area. The top of the debris fence must be a minimum of 2.44m in height and must incorporate at least 2 strands of 10mm steel cable evenly spaced and securely anchored at each end.
 - (d) All grandstands must be in compliance with State and Municipal regulations.
 - (e) All spectators must be warned throughout the event not to place or allow children to sit or lie in the footboard area. Special emphasis in the warning should be addressed to parents monitoring their children at all times.
 - (f) Further signage re-emphasizing this warning must be posted prominently at every entrance to the facility.
- 2.1.13 Pit Area
Tracks intending to host National Championship events should provide facilities for 150 competitors. Pit Area should be rendered dust free (grassed, sealed) and suitable access should be provided between this area, the Staging Lines, and the Return Road.
- 2.1.14 Staging Lines
Minimum of four lines 3.0m wide sealed surface leading into the burnout area.
- 2.1.15 Tender/Trailer Park
An area reasonably accessible from the Pits must be available for parking/storage of trailers and vehicles.
- 2.1.16 Weighing Facilities
Equipment must be available to weigh those vehicles subject to weight/capacity, or minimum weight regulations. Vehicles may be weighed one axle at a time, and the area over which the weighing takes place should be flat over a suitable distance for weighing of the longest vehicles.
- 2.1.17 Scrutineering Facilities
At least one drive through bay 20 feet square (6 meters), with a sealed floor, must be provided for Scrutineering/Classification purposes. A roofed double bay, closed on the prevailing weather side is recommended.
- 2.1.18 Timing Equipment
- (a) A full electronic timing system is required at all events.
 - (b) The timing equipment should be constructed in such a manner as to measure Reaction Time, Elapsed Time (to one thousandth of a second) and Terminal Speed (to one hundredth of a kph).
 - (c) Foul starts must be indicated by a red light at the bottom of the Christmas Tree should in the lane in which they first occur, triggered by the timing system if the timers start before the green light shows.
- 2.1.19 Christmas Tree

The Start line display referred to as the Christmas tree should be clearly visible to vehicles in the staging/Start line area of each lane. A “Pro-Start” facility must be available.

- (a) Handicaps
Handicap facilities, accurate to 0,001 seconds are required.
- (b) Pre-Stage Beam
Located (200mm) before the Stage beam in each lane. Its only purpose is to show the competitor that the vehicle's front wheel is approaching the Stage Beam by illuminating a Pre-stage light at the top of the Christmas tree.
- (c) Stage Beam
Located (405mm) before the Guard Beam in each lane, it indicated that the vehicle is in the correct position for the start. The Stage Light at the top of the Christmas tree should activate when the leading edge of the vehicle's front wheel breaks the Stage Beam. The Stage Beam also serves to start the ET timers as the wheel clears the beam, and activates the red “foul” light in the event of the wheel clearing that beam prior to the green light showing
- (d) Guard Beam
Located at the start of the Timed Distance the Guard Beam ensures that no vehicle has an excessive amount of roll-out (movement required to leave the Stage Beam). If the Guard Beam is broken at the same time as the Stage Beam and the starting sequence has been initiated, the timers, and the red “foul” light will be activated if the green light is not showing.
- (e) Finish Line Beam
The Elapsed Time Beam is located at the Finish Line in each lane, 1320 feet (402.336m) from the Guard Beam. It indicates which competitor reached the Finish Line first and stops the timers. Elapsed times must be available to competitors in written or printed form.
- (f) Speed Traps
These are located adjacent to the Finish Line, using photocells at a distance of either 166 or 132 feet (20.1m or 40.2m) to measure the Terminal Speed of the vehicle in each lane, independently of the Elapsed Time. Terminal speeds must be available to competitors in written or printed form.
- (g) Photocell Heights
Ideally, all light sources, sensors and reflectors should be mounted as close as possible to the level of the track surface with the filament in the vertical position the roll-out at the Start Line should be parallel. Apart from the start line, all fittings on the Racing or breaking surfaces should be of the “breakaway type”.

- 2.1.20 Strip Markings
The track boundaries and the centerline must be clearly marked with a white line, at least 100mm in width. The speed traps should be clearly marked on the track surface with diagonal lines, before and after the finish line.
- 2.1.21 Track Officials
The track management will provide and supervise such trained Officials as are deemed to be necessary for the safe and efficient conduct of all Drag Racing events. All Officials in areas beyond the start line should be located in protected positions.
- 2.1.22 Medical Facilities
To conform to 2026 Appendix “L”
- 2.1.23 Fire Equipment
Fire and Rescue Intervention Vehicle to conform to 2026 Appendix “L”
- 2.1.24 Bridges
A minimum of 6m clearance at the lowest point of bridge to roadway.

2.2 GRADE C FACILITIES

- 2.2.1 Width: Minimum 9.0m
- 2.2.2 Length: Minimum 800m
- 2.2.3 Level Variation: As per Grade B
- 2.2.4 Return Road/Turnoffs: As per Grade B
- 2.2.5 Safety Barriers: Three-tiered Armco railing, utilizing the FIA specification.
- 2.2.6 Spectator Fence: As per Grade B
- 2.2.7 Strip Marking: As per Grade B
- 2.2.8 Timing Equipment: As per Grade B

2.2.9	Track Officials:	As per Grade B
2.2.10	Medical Facilities:	2026 Appendix "L"
2.2.11	Fire and Rescue Facilities:	2026 Appendix "L"

2.3 OTHER FACILITIES

Street Drags

2.3.1 Limited Competition Drag Strips:

Other venues, apart from public roads such as airports and circuit Racing venues, can be sanctioned by MSA for either regular or individual Drag Racing events. Due to the varied nature and track length of these venues, the types of vehicles, which can compete at sanctioned meetings, will be determined on a case-by-case basis. MSA may allow certain classes to compete at specific venues after an inspection/s have been carried out by the MSA Safety Panel member/s and approved.

2.4 DRAG RACING EVENTS ON PUBLIC ROADS

Drag Racing events may be sanctioned on public roads specifically closed for the purpose for either regular or individual events with the following minimum criteria being applicable.

- 2.4.1 The roads to be utilized must be officially closed for the purpose by the controlling local authority.
- 2.4.2 The competition will be conducted under the Street Racing Rules and will only be permitted between vehicles complying with the Street Drag Racing Class Regulations.
- 2.4.3 The competition will be restricted to vehicles running not quicker than 11.00 seconds.
- 2.4.4 All other vehicles may be permitted to make single exhibition runs under certain criteria as set by MSA on a case-by-case basis.
- 2.4.5 Temporary Sites not using approved barriers must limit spectator access to defined areas extending diagonally away from the Start Line and Racing surface.
- 2.4.6 This criterion may be amended by MSA if adequate alternative safety measures exist at any site (such as natural banks, ditches, existing road barriers, etc.)
- 2.4.7 Prior to the first event being held on any street course, the MSA Safety Panel must inspect the areas and forward a report to MSA detailing the grounds under which the venue shall be approved or a recommendation not to approve the venue if it is not suitable. The final decision to approve all venues rests with MSA.

2.5 MAXIMUM PERMISSIBLE ELAPSED TIME AND SPEEDS

Due to the varied nature and track width & length of these venues, the types of vehicles, which can compete at sanctioned meetings, will be determined on a case-by-case basis. MSA may allow certain classes to compete at specific venues after an inspection/s have been carried out by the MSA Safety Panel member/s and approved.

With regards to facilities where the Drag Strip is less than 15.2 meters wide, no parachute cars may race heads up and only single runs may be done.

TR 3 OFFICIALS

The officials listed in sub-articles (b) to (q) hereof, are mandatory for all status events. They shall be present throughout practice and racing and shall be responsible for carrying out the duties defined.

- 3.1 MSA Steward: Shall be appointed by MSA and responsible to MSA. For any National Championship event, they must hold a Clerk of the Course licence for Drag racing.
- 3.2 Club Stewards: May be appointed by the organisers of each Drag race meeting to act with the appointed MSA Steward.
- 3.3 Powers and responsibilities of Stewards of meeting: Refer to GCR 152. Stewards of the meeting report: Refer to GCR 154.
- 3.4 Clerk of the Course: Must hold a license valid for the grade of the meeting.
Duties and powers of the Clerk of the Course: Refer to GCR 156.
- 3.5 Medical organization: As per 2026 MSA Appendix L
- 3.6 Scrutineers and assistants: Shall be licensed by MSA. Refer to GCR 166 for duties.
- 3.7 Chief Timekeeper: Refer to GCR 163.
- 3.8 Chief Scorer: With the aid of adequate assistance, shall record the results of each race.
- 3.9 Starter: To ensure that racers are correctly started and finished, and the proper signals given. Refer to GCR 160.
- 3.10 Chief Course Marshal: in accordance with GCR 171 shall be responsible:
 - 3.10.1 To ensure with the aid of at least four assistants, that the strip surface and marking and protective works are maintained in good order throughout the meeting.
 - 3.10.2 To ensure that the firefighting equipment is readily available and correctly sited and that his assistants and the Paddock Marshals are familiar with its operation.
 - 3.10.3 To ensure that the strip cleaning units are sited at suitable points.

- 3.10.4 To supervise the removal from the strip of any vehicle that may have stopped on the tarmac.
- 3.10.5 To see that all entrances to the strip proper are manned and that no unauthorized person comes within this area. Normally more than four assistants will be required, and if enclosures are not surrounded by unclimbable fencing there must be course marshals stationed at strategic points between all enclosures and the strip proper.
- 3.11 Chief Paddock Marshal: shall be responsible for:
- (a) To maintain orderly conduct in the paddock and/or pit area.
 - (b) To notify competitors to assemble on the dummy grid prior to each heat.
 - (c) To exclude any unauthorized persons from the paddock and/or pit area.
- 3.12 Secretary of the meeting: Duties as detailed in GCR 159.
- 3.13 General officials: To be present in a number adequate to control admission to all enclosures, to operate car parking, distribute programs, etc. All officials shall be suitably identified.
- 3.14 Technical Consultant: Refer to GCR 167 for duties. Is mandatory at National Championship events.

TR 4 FEES

Organiser/Promoter shall be responsible for payment to MSA of the fees prescribed from time to time by MSA, including but not limited to permit fees, public liability fees, trust fund levy. MSA reserves the right to withhold permits if fee invoices are in arrears.

TR 5 INSURANCE

Reserved

TR 6 RIGHTS AND DUTIES OF ORGANISERS

Refer to the applicable MSA GCRs and SSRs

TR 7 RESPONSIBILITIES OF ORGANISERS/PROMOTORS

Refer to Part VI of the 2026 GCRs.

TR 8 PENALTIES

Any breach of these regulations or the supplementary regulations for any competition, whether or not any penalty is specified therein, may be subject to the penalties laid down in the GCRs and the imposition of such conditions as MSA may deem appropriate.

TR 9 SCRUTINEERING

After an event, the Clerk of the Course or Stewards in the case of a protest may instruct those vehicles to be impounded for examination by the scrutineers and/or appointed technical consultant for examination by the scrutineers to determine if they comply with the regulations. Any vehicles failing to comply shall be excluded from the results of the event. Refusal to submit a vehicle for scrutiny as directed shall result in automatic exclusion and further disciplinary action. All nuts, bolts and component parts on each vehicle's suspension system, chassis and running gear must be secured with either lock nuts, lock washers or split pins. All nuts and bolts must have full thread engagement.

VEHICLE CONSTRUCTION AND GENERAL SAFETY REGULATIONS

In interpreting these construction and class regulations and specifications the principle of "what is not specifically permitted is disallowed" (GCR 226) shall apply. These construction rules apply to all categories. The category regulation may restrict these rules or permit further modifications. It follows that the category regulations are subject to these regulations unless specifically stated otherwise. They shall be viewed in the narrowest sense and in the interpretation of these regulations; officials shall have regard only to what is stated and not what is implied. Throughout the rules aluminum sheet of 1.6 mm may be utilized to replace metal plate with a thickness of 1 mm, provided the use of aluminum is not specifically excluded. Whenever reference is made to the weight of vehicles it shall include fuel and the competitor after completion of a run.

CR 1 AEROFOIL

A positive locking device to prevent movement is mandatory. No part of the rear foil to be within 150mm of tyres. Spring loaded spoilers, wings or canards prohibited. Adjustment of airfoils, wings or spoilers not permitted during runs. Front overhang for all vehicle spoilers is a maximum of 1016mm. All front overhangs are measured from centerline of front spindle to forward most point on vehicle.

CR 2 ALIGNMENT

Each car, regardless of class, must have sufficient adjustment of front alignment to ensure proper handling of the car at all speeds.

CR 3 ANTI-BLOWBACK DEVICE

This is mandatory for all vehicles in category "MODIFIED RACE". Brace or device must be installed that will prevent the clutch can or adaptor shield from being blown backwards in the event of a flywheel and/or clutch explosion. Minimum material requirement is OD .083" wall chrome moly tubing with 10mm fasteners. Ball lock pins prohibited!

CR 4 ARM RESTRAINTS

Arm restraints are mandatory for all Funny cars and open cockpit vehicles capable of running faster than 11.999 seconds. Restraints must be adjusted so that the driver's arms cannot extend beyond the confines of the roll cage, shoulder hoop, etc.

CR 5 AUTOMATIC TRANSMISSION PROTECTION

- 5.1 The following vehicles using OEM automatic transmissions must be fitted with an approved scatter blanket or a protective shield:
- 5.1.1 All Modified Street, Modified Race and open cockpit vehicles.
 - 5.1.2 All vehicles using transmission brakes.
 - 5.1.3 All supercharged vehicles (including nitrous) that run faster than 10.500 seconds over the quarter mile.
 - 5.1.4 All vehicles: regardless of category, that run faster than 9.000 seconds over the quarter mile.
- 5.2 The protective shield must be fabricated from a minimum of 3mm aluminum and must cover the main body of the gearbox, offering 180° of protection (pan rail to pan rail). It must be securely mounted with two steel straps passing under the transmission.
- 5.3 A 3mm aluminum flex plate shield covering the top 180° measuring 25mm either side of the front and rear of flex plate must be mounted securely to chassis, frame, or other suitable member to protect the driver from exploding fragments.
- 5.4 Alternatively, a 13mm thick piece of conveyer belting may be securely wrapped around the required areas or fastened permanently to the floor pan inside the vehicle.
- Note: Where other than original torque converters are used all mounting tabs and spacers must be suitably reinforced. All transmission lines must be high pressure-type hoses.

CR 6 AUTOMATIC TRANSMISSION GEAR SHIFTERS

Any non-OEM automatic floor mounted automatic transmission shifter (i.e., homemade) must be equipped with a spring-loaded positive lockout device to prevent the shifter from accidentally being put into reverse gear. A functional neutral safety switch is mandatory.

CR 7 BALLAST

Any material used for the purpose of adding to the vehicle's total mass must be permanently attached as part of the car's structure and must not extend behind the rear of the body or above the height of the rear tyres. Ballast carried in the boot, or the trunk will only be permitted if the class allows. No liquid other than the fuel being used to propel the vehicle is permitted behind the front firewall. A maximum of 100kgs removable mass, if class permits, may be added. Not more than 40kgs may be mounted as one single removable mass by at least two 12mm steel bolts or equally strong straps or clamps and must be purposely made weights. (If more than 40kgs is needed, more than one unit is required).

CR 8 BATTERIES

- 8.1 All wet cell car batteries must be located outside the driver or passenger compartment and must be securely mounted with metal hold-down straps and 10mm bolts if battery is relocated from stock or other than stock hold-downs are utilized.
- 8.2 In open cars where acid spillage over the driver can occur in an accident, some form of covering over the battery is required to prevent this situation.
- 8.3 A maximum of two batteries may be fitted provided their combined weight does not exceed 50kgs. Onus is on the competitor to prove their vehicle's combined battery weight is under the acceptable limit. If two batteries are fitted, it needs to be marked that way at the isolator switch, and both batteries need to be in the same compartment.
- 8.4 Any car with a battery fitted, running quicker than 9.99 seconds and any single purpose drag racing vehicle must incorporate a battery isolation switch capable of shutting of current flow and be operable from the exterior of the vehicle.
- 8.5 It is also recommended that sedan vehicles with trunk-mounted batteries have a trunk key permanently fitted to the lock. A cut-off switch must be connected to the positive side of the electrical system. The "ON" and "OFF" positions must be clearly indicated with the words "ON and OFF".

CR 9 BATTERY LOCATION MARKERS

A three-inch equilateral triangle, colored blue, is required on all vehicles fitted with a wet cell battery or batteries to accurately indicate the battery location. Should the colour of the marker not contrast sufficiently with the vehicle body colour, an additional white border, 2cm wide is required. If a vehicle incorporates a "Battery Cut-Out" switch, the location marker may be placed around the switch to indicate the position. Where more than one battery is fitted in different locations, a marker is required to indicate the position of both batteries.

CR 10 BRAKES

Brakes must be in good working order with two-wheel hydraulic brakes (rear wheels only) as a minimum requirement for vehicles under 910kg. Four-wheel hydraulic brakes are required where noted under category requirements. Lightening of backing plates, brake drums and/or brake shoes by cutting or trimming metal is not permitted. Cooling holes must be drilled in such a manner that they do not weaken the unit and must carry cooling scoops. The drilling of cooling holes in cast iron disc rotors is prohibited. If a hand brake is fitted, the brake handle must be inside of the body confines or driver's compartment. Front wheel drive vehicles may use rear brakes as staging brakes provided the vehicle is fitted with a

parachute as a back-up stopping device. Brake lines must be attached to chassis as per OEM style: No Tie-straps and must be routed inside the frame or body and be enclosed in a 45cm length of 3mm wall thickness steel tubing and securely mounted where the brake lines pass the flywheel/bell housing area. All brake lines on any rear-engine car must be routed inside of the approved steel tubing or be of braided steel construction where they pass the flywheel/bell housing area. A supplementary or back-up brake system is compulsory on all cars. All pedals must be covered with a non-slip material.

CR11 BURNOUTS

No person is permitted to hold or touch vehicles during burnouts (including motorcycles). Motorcycles are not permitted to do "U" turns after burnouts.

CR12 CLUTCH

All cars, except those fitted with a torque converter, must have a foot-operated clutch. All pedals must be covered with a non-slip material.

CR13 COOLING SYSTEM

If a cooling system is utilized, it must be installed in the stock location for the body style used. Front engine dragsters must have the system installed in front of the engine. In the event of a rear-engine dragster with a radiator mounted in front of the motor, a deflector must be installed from frame rail to frame rail and to the top of the roll cage. No anti-freeze may be used in drag-classes categories such as all vehicles running in ~~Top Eliminator, all Altered and~~ the Modified Category.

CR14 DEFLECTOR PLATE

All rear-engine vehicles must have a deflector plate to protect the driver from the engine. Plates must extend from top blower pulley to bottom pulley and be at least 25mm wider than each pulley for supercharged cars, whilst others must have plate covering from shoulder height to bottom of chassis. Minimum attachment for any plate is four 10mm high tensile bolts.

CR15 DELAY BOXES

Any electrical, pneumatic, mechanical, or other device attached to existing components that intentionally creates a delay between the driver releasing the clutch, trans brake, etc., and the forward movement of the vehicle will be considered a delay device and is prohibited.

CR16 DRIVELINES

16.1 On any car where the driver sits over or behind the engine, a suitable protective shield of 3mm minimum thickness steel plate must be installed over these units with universal joints securely mounted to the rear and center section and the gearbox tail housing. Couplings are highly recommended in place of U-joints wherever possible. For those units with straight couplings, the minimum requirement is 2mm thickness aluminum which must contain an inspection cover for the removal and inspection of the coupling and must be securely mounted or as noted in the Class Requirements.

16.2 In place of a cross member in the immediate vicinity of the front universal joint, all competition cars using open drive shafts must have a 360° retainer loop of 6mm thickness and 50mm width securely mounted and located within 150mm of the front and rear universal joints to support the drive shaft in the event of a U-joint failure. Open drivelines passing any part of the driver's body must be completely enclosed in a 3mm thickness steel plate securely mounted to the frame or frame structure. All cars using open Hotchkiss-type drivelines must have radius arms, traction bars, or some suitable pinion support to prevent rear end housing rotation. It is highly recommended that a torque tube be used to enclose all drivelines.

CR17 DRIVELINE ANTI-ROTATION DEVICE

An anti-rotation device is required in any vehicle where the driver sits over or behind the rear-end (differential).

CR18 DRIVER'S COMPARTMENT

All interior panels (firewalls, floors, wheel tubs, doors, etc.) within the driver's compartment of enclosed-cockpit vehicles where the driver is located behind the engine must be constructed of materials other than magnesium and/or non-flammable materials.

CR19 ENGINE

With the exception of exhibition vehicles, all engines used in the Drag Racing must be of automotive type origin. Crankshaft center lines may not exceed 600mm from the ground in any class.

CR20 ESCAPE HATCH (FUNNY CARS)

A working escape hatch must be installed in the roof of all Funny Car bodies that have enclosed side windows to permit easy driver exit. See through types are prohibited. Minimum size is 500mm x 500mm. Roof hatch must be permanently attached and hinged at the front and must have a release mechanism operable from both inside and outside the car.

CR21 EXHAUST

21.1 Each car, regardless of ~~class~~ category, must be equipped with exhaust pipes to direct the exhaust gasses out of the car body to the rear or side of the car away from the driver, fuel tank and strip surface. Individual exhaust stacks must incorporate a metal connecting strap to prevent loss of one or more stacks during competition. If an exhaust exits through the bonnet, it MUST be angled / re-directed away from the driver's side of the compartment /windscreen.

21.2 All Turbo charged vehicles with an open exhaust system must have a steel cross welded into the tailpiece of the exhaust system to contain any turbo debris in case of a turbo failure.

CR22 FIRE EXTINGUISHERS AND FIRE BLANKETS

22.1 An on-board fire extinguisher system is mandatory under certain class requirements.

- When required, a minimum 1,5kg capacity extinguisher securely mounted, with a steel bracket, consisting of at least 1 steel strap (no tie-straps) and within easy reach of the driver when he/she is wearing a safety harness.
- 22.2 Irrespective of whether the fire extinguisher or on-board extinguisher system is not fitted with a gauge or not, the recent inspection/service label must be displayed, service intervals of 12 months for fire extinguishers and 24 months for on-board extinguisher systems are mandatory. It is the responsibility of the competitor to weigh the extinguisher prior to each event.
- 22.3 Funny cars – All cars must be fitted with a manually controlled pull-type only, on-board fire extinguisher system with the primary nozzle(s) directed to protect the driver. Bottles and lines must be permanently mounted, i.e., no hose clamps or cable ties.
- 22.4 In the case of more than one bottle, each bottle must have its own steel distribution tubing and nozzles. Nozzle placement is extremely important. Two nozzles are placed at the front of the engine directed into the compartment on either bank of the exhaust headers whilst another nozzle or nozzles should be positioned into the drivers' compartment using an atomizing unit placed at the drivers' feet or near the steering column.
- 22.5 Upon activation of the system, the contents of the bottle(s) must be totally discharged. Partial discharge systems are not permitted. The bottles must be mounted in such a manner that should an explosion or failure of any mechanical component of the vehicle occur, the bottles will be protected from flying parts as well as being high enough to not come into contact with the track surface, following a loss of tyres or wheels.
- 22.6 Bottles should be protected from excessive temperature, and remote cables must be metallic without plastic coatings that will melt and jam the mechanism in cases of fire.
- 22.7 "Fire Windows" measuring no greater than 60 square centimeters on either side of the firewall in the vicinity of the valve covers to warn driver of fire are mandatory. Best results are obtained from laminated safety glass or fire-resistant plastics like Lexan or Plex 70.

CR23 FIRE BLANKET

Blankets may be fireproofed by immersing in a solution of 240 grams of Boric Acid dissolved in 5 liters of water. Hand-wring and hang to dry. Repeat after each wash. It is recommended that each entrant have a treated fire blanket on hand in the pit area.

CR24 FIREWALLS

Each car must be equipped with a flame proof and fuel proof firewall extending from the body sides and from the top of the engine compartment upper seal, i.e., hood, cowl, or deck, to the bottom of the floor and/or belly pan. The firewall must be constructed to provide a leak proof bulkhead between the engine and driver's compartment. All holes or openings must be sealed with metal or a fireproof material.

CR25 FLASH SHIELDS

Injector tubes may extend through individual holes in the hood/bonnet, but carburetors must not be openly exposed or uncovered. In place of a hood/bonnet, carburetors must be equipped with a metal flash shield or velocity stack that prevents fuel from being siphoned into the air stream or blown into the driver's face.

CR26 FLOORS

All cars without floors must be equipped with floor pans made of steel or aluminum that must extend the full length and width of the driver compartment to the rear of the driver's seat. Cars equipped with floors or belly pans made of fiberglass or other breakable material must have metal sub floors. In all cars with OEM fiberglass floors, a cross member (minimum 2 inches x 2 inches, .083-inch wall-thickness square tubing) must be installed between frame rails for proper driver's seat, seat belt, shoulder harness and crotch strap installation. Belly pans and sub floors enclosing engine or driver compartment must contain suitable drain holes so that liquids and foreign matter cannot collect, thus creating a fire hazard. Minimum .032-inch aluminum or .024-inch steel. In certain instances, a panel made of composite material may be substituted for steel or aluminum. Use of magnesium prohibited.

CR27 FLYWHEELS

All vehicles in competition with the exception of sedan vehicles known not to be capable of quarter-mile performances better than 11.999 seconds are required to be fitted with either a steel or alloy flywheel or an acceptable scatter shield as outlined in the following regulation. No excessively machined unit of cast iron or any other material will be accepted. Vehicles revving over 6000 rpm may not make use of any cast flywheels and/or cast-iron inertia rings attached to the flywheels. Inertia rings / weights MUST be made out of Steel.

CR28 FLYWHEEL SHIELDS (All "Modified" Vehicles)

- 28.1 All rear-wheel drive manual gearshift vehicles in category " Modified" must be equipped with a suitable shield made of 6mm minimum steel plate securely mounted to the frame or frame structure and completely surrounding the bell housing (full 360°) to protect frame, driver, and bystanders from fragments in case of clutch/flywheel disintegration.
- 28.2 Alternatively, a 13mm thick piece of conveyer belting may be securely wrapped around the required area or fastened permanently to the floor pan inside the vehicle. Any vehicle utilizing an aluminum bell housing, regardless of performance, must at minimum adhere to the conveyer belting regulation.
- 28.3 Shields must not be attached to the bell housing in any way. The flywheel shield must be constructed in such a manner that it covers the top, sides, and rear of the enclosed bell housing completely, shielding the transmission bell and mounting flange to stop fragments entering the driver's compartment.

- 28.4 The 6mm steel plate must at minimum extend forward to a point 25mm ahead of the flywheel and also another 25mm past the rear of the clutch and pressure plate.
- 28.5 An engine support strap either in the form of a 3mm steel motor plate, 6mm T6 aluminum motor plate or aircraft quality cable (chain is unacceptable) must support the rear of the engine in case of clutch or flywheel disintegration. This requirement is mandatory on all vehicles using a manual gearbox from Street Modified upwards unless it is evident that the headers, frame rails, etc., will prevent the engine from dropping to the surface of the track.
- 28.6 Vehicles using a conventional clutch/pressure plate/flywheel to drive an automatic gearbox must comply with the aforementioned flywheel shield rule.
- 28.7 A totally enclosed 360° one-piece bell housing/adaptor fabricated from 6mm steel plate and securely mounted using all available engine/transmission mounting points is acceptable in lieu of conventional shields and is recognized as a better alternative to the above method of concealing a clutch/flywheel explosion.
- 28.8 Flywheel shields are highly recommended on all vehicles including streetcars revving higher than 5000 RPM.
- 28.9 All Front Wheel drive or transverse mounted applications in category "Modified" using a clutch must be equipped with a flywheel shield made of 6mm thickness steel plate. This shield must surround the bellhousing completely except for area of bell-housing adjacent to the differential axle shaft. This shield may be multi-piece, with pieces bolted together using minimum 10mm or 3/8"8.8 grade high tensile bolts and must be attached to engine and bellhousing.

CR29 FLYWHEEL SHIELDS

Vehicles fitting category "Modified"-The use of a shield constructed to the following specifications is mandatory in all clutch-equipped vehicles running in the above classes over the 1/4 mile.

- 29.1 All existing bolt holes must be utilized to secure the flywheel shield.
- 29.2 Vent holes must be contained below the crankshaft center line and limited to a maximum 10cm.
- 29.3 A clutch inspection and maintenance hole may be cut on the back face of the housing. The hole may not be longer than an area covering 90° of the housing rear surface area.
- 29.4 No part of the rotating clutch assembly may extend past the forward edge of the inspection hole on housings with a radiused back.
- 29.5 A cover for the inspection-hole must be at least 6mm thick and be fastened with at least six 10mm high tensile bolts.
- 29.6 The abovementioned inspection-hole cover must incorporate a 6mm fillet welded precisely to fill the hole, so it is flush in the inside of the housing.
- 29.7 Starter motor pocket if utilized, must be of the same material and thickness as the bell housing.
- 29.8 Scalloping of bell housing flange is accepted if at least 6mm of material is maintained between the radius and edge of the flange.
- 29.9 Motor plate must be of 6mm aluminum T6 plate or 3mm steel for full coverage style with a minimum hole for crank flange to pass through.
- 29.10 A crower glide clutch-adjustment slot (one only) is accepted if made precisely to the specifications as outlined in the illustration using a 6mm steel cover.

CR30 FRAME/CHASSIS

All butt-welds must have visible reinforcement. Flush grinding of welds is not permitted. The use of materials other than steel is permitted providing it can be proven the material and welding thereof is stronger than its equivalent in steel. Refer also to roll cage regulations.

CR31 FUEL

- 31.1 Service station pump petrol, aviation fuel, racing fuel, ethanol and methanol as sold to the general public through normal retail outlets is permitted.
- 31.2 Approved International Fuels
 - (a) VP Racing Fuels:
As per Product Catalogue, revised from time to time
 - (b) Philips/Trick:
As per Product Catalogue, revised from time to time
 - (c) Sunoco:
As per Product Catalogue, revised from time to time
 - (d) Torco:
As per Product Catalogue, revised from time to time
 - (e) 76:
As per Product Catalogue, revised from time to time

WARNING: The current method to increase octane in both leaded and unleaded petrol is to increase the number of aromatic hydrocarbons such as benzene, toluene, xylene, and associated compounds. The higher the concentration of certain aromatic hydrocarbons, the higher the octane rating. These compounds cause cancer. The higher the concentration in petrol, the higher the risk of leukemia (blood cancer) and other cancers.

The use of Hydrazine or any other chemicals (other than nitro and alcohol blends) designed to alter volatility or chemical composition of the permitted fuel, is totally banned. Use or possession of such material at the Drag strip carries severe penalties.

- 31.3 The use of Nitromethane will only be permitted in "Exhibition" or "Top Fuel" classified vehicles.
- 31.4 The use of Methanol and 100% Ethanol fuel will only be permitted the Modified car Category. The use of "E85" will be permitted in the True Street Car Category. The use of Methanol in any concentration in the True Street Car Category is prohibited.
- 31.5 Any vehicle that uses Methanol / Ethanol, as fuel must indicate its use by displaying an orange circle of 100mm diameter with an M / E inside the circle.
Drivers are advised to study the safety requirements set out under CR 31.2 read with CR58.4 and CR 58.5.
Note: Refer to special MSA circular on approved fuels.

31.6 Random fuel sampling will be done at all championship events, Regional, National, Interprovincial and International at the discretion of the Clerk of the Course. Refer to GCR 240

CR32 FUEL SYSTEMS AND FUEL TANKS

- 32.1 Wherever permitted in category "Modified" regulations, fuel tanks and fuel lines should be located ahead of the engine. Fuel blocks, if used, must be mounted at least 150mm forward of the flywheel/bell housing area.
- 32.2 Fuel lines in the flywheel/bell housing area must be enclosed in a 3mm wall thickness; 450mm length of steel tubing securely mounted or alternatively re-routed outside the chassis or frame rails as a protection against fuel lines being severed in a clutch/flywheel explosion.
- 32.3 In the event of a fuel line passing the supercharger drive areas, a compulsory steel tube protection is required if braided steel line with suitable aircraft quality fittings is not utilized.
- 32.4 Fuel tanks located in front of the vehicle's grille and outside the protected areas of the body, frame, and wheels, must be protected against collision damage by some means of encasement, (i.e., steel bump bars).
- 32.5 All supercharged and/or fuel injected vehicles as well as vehicles using an altered fuel system (other than electric pumps), must have a quick action positive fuel shut-off valve of control within each reach of the driver and must be located in the main line between the fuel tank and carburetor(s) or injection unit.
- 32.6 It is mandatory that fuel pumps be located away from the flywheel area wherever possible.
- 32.7 Under no circumstances are any fuel tanks, lines, fuel pressure gauges or other units containing fuel permitted in the driver's compartment. All tanks must be completely isolated from the driver's compartment by a firewall completely sealed so as to prevent any fuel from entering. All vehicles where a fuel line passes the driver must be fitted with metal lines except for a maximum of 30cm of approved flexible fuel hose to allow for connection purposes only. Recognized steel braided flexible lines may be used in lieu of solid metal lines.
- 32.8 Top of fuel tank must be below top of vehicle's rear tyres. All fuel tanks must have a positive locking fuel cap and be vented to the outside of the body or have a built-in check valve.
- 32.9 When allowed by class requirements, all fuel cells must have a metal box protecting the part of the cell that would be outside bodylines or trunk floor. All fuel cells must have a pressure cap and be vented to the outside of the body or have a built-in check valve.
- 32.10 Where the fuel tank is located in front of the driver and engine in the rear (rear-engine Dragsters) fuel lines must be isolated from the driver's compartment with a sub-floor or by use of steel braided liens. The adding of fuel while an engine is running is strictly prohibited and is grounds for exclusion.

CR33 GOGGLES

Windproof, shatterproof goggles or visors must be worn by all drivers of vehicles not having windscreens. Fire resistant goggles and/or facemask material are mandatory for supercharged or nitro-burning vehicles.

CR34 HARMONIC BALANCERS

- 34.1 All sedan or bakkie type vehicles in category "Modified" and all Dragsters, Funny Cars, and vehicles where the engine is NOT enclosed must be fitted with either an explosion-proof harmonic balancer or a harmonic balancer scatter shield.
- 34.2 The harmonic balancer scatter shield must be constructed of 6mm thick steel plate securely fastened with at least two 10mm high tensile bolts in such a manner as to contain or deflect fragments should the balancer disintegrate. The width and circumference of the outer ring must be covered, and the front of the shield should extend down at least to the level of the rubber ring in order to retain fragments or to prevent the outer ring from coming forward. A 10mm diameter hole may be drilled in the shield for timing mark purposes. No other openings are allowed.
- 34.3 Vehicles using a steel outer ring do not require a shield, but the outer ring must have some positive means of preventing it from moving forward. This can be achieved by having a step on the back of the ring or a front retaining plate equal to the other diameter of the ring made from minimum 3m steel plate or 6mm alloy plate.
- 34.4 All pulleys/crank hubs/harmonic balancers must be positively fixed to the crankshaft by bolts or pins.

CR35 HEAD PROTECTION

In any car where a roll bar or roll cage is installed, a padded head protector must be provided at the back of the driver's head and constructed to prevent whiplash upon impact. The roll bar or cage must be padded wherever it touches the driver's helmet or other body contact area. A seat, which incorporates a correctly adjusted headrest to within 100mm of the back of the helmet, is acceptable.

CR36	HELMETS
36.1	All drivers/riders in all classes must wear a properly affixed SABS approved, or its equivalent, safety helmet while in practice or competition on the Drag strip.
36.2	Open-faced helmets or Off-Road motorcycle type helmets are permitted in closed cars provided it can be established that a face mask or respirator is necessary such as in FC vehicles and methanol burning sedans. However, full-face helmets with built-in respirators are the accepted norm for this purpose. Note: Helmets are inspected as an essential part of the vehicle's safety equipment. Helmet straps should be worn beneath the chin. Chin guards or other devices that prevent the proper location of helmet straps are prohibited. The helmet of any competitor involved in an accident, collision or upset must be surrendered to the MSA Steward at the event for inspection.
CR37	HYDRAZINE
	No Hydrazine is allowed in any class under any circumstances.
CR38	IGNITION SYSTEMS
38.1	Except for fuel injected vehicles with a mechanical fuel shut off, all vehicles must have a positive action on/off switch in good working order within easy reach of the driver and clearly marked "ON/OFF".
38.2	Each car in competition must have a positive action on/off switch, capable of de-energizing the entire ignition system, in good working order, located within easy reach of the driver. "Momentary contact" switch prohibited. Magneto "kill button"-type switches are prohibited. All ignition systems and/or components wiring harnesses and attachments must utilize those supplied by the ignition system manufacturer. The wiring harness must be used in an unaltered manner consistent with the manufacturer's installation and instruction books.
CR39	INTERCOOLERS
	There is no restriction on intercoolers but no external cooling by any liquids that may leak onto the track may be used on the pre-race line-up area or on the track.
CR40	INSPECTION
	Each vehicle, regardless of class, must complete and satisfactorily pass the inspection of the Technical Inspectors before being allowed a trial run or to participate in any Drag Racing event. All nuts, bolts and component parts on each vehicle's suspension system, chassis and running gear must be secured with lock nuts, lock washers, cotter pins or safety locking wire and must have at least one full thread showing through the nut.
CR41	JACK AND JACKSTANDS (TRESTLES)
	No work may be done under any vehicle in the pit area while it is supported by only one jack. Additional safety devices such as jack stands are required to ensure safety in the event of jack failure.
41.1	Engines may not be started while driving wheels are off the ground and not supported by adequate jack stands.
41.2	Failure to observe these jacks stand rules are grounds of instant exclusion.
CR42	LATCHES
	Where a body is of the "flip-top" type, the latch must be located in the centre of the front face of the body. All vehicles with left-off doors must have safety pins or locks fitted to the hinges.
CR43	LAUNCH CONTROL/TWO-STEP/TRANSBRAKE
	Driving wheels must be off the ground and on trestles with the driver inside the vehicle.
CR44	LIFTING DEVICES
	Any form of mechanical, hydraulic, or other leverage-type device for raising a vehicle's driving wheels and tyres off the strip surface in the starting area is prohibited.
CR45	LIQUID OVERFLOW/CATCH TANKS
	All machines with any type of liquid capable of dumping or spilling on the track surface, must have a "catch can" to recover the excess liquids. Minimum capacity for all vehicles is one liter. Overflow may be routed into headers on cars, which are supercharged or burn nitro or methanol.
CR46	MAGNAFLUX CERTIFICATES
	As protection against parts failure, each vehicle owner should voluntarily obtain a Magnaflux inspection certificate for altered or welded parts. Magnaflux certificates may be required by the scrutineer on any modified or welded parts.
CR47	NITROUS OXIDE SYSTEMS
47.1	Nitrous oxide bottles must be securely mounted in the boot or rear of the vehicle. Any such vehicle using a nitrous oxide system is required to have a leak-proof bulkhead between the boot of the vehicle and the driver's compartment.
47.2	Where no boot space exists in a vehicle (i.e., hatchbacks), the nitrous oxide bottle can be securely mounted (no hose clamps or cable ties) with steel brackets in the passenger's compartment.
47.3	All nitrous oxide systems not isolated from the driver by a leak-proof bulkhead must be equipped with a relief valve and be directly vented to the outside of the driver's compartment utilizing a flexible fuel line to disperse gas leakage into the atmosphere.
47.4	Where nitrous lines pass the converter or flywheel area, they must be encased in 3mm thickness steel tubing for 450mm or alternatively be re-routed outside the chassis or frame rails. All flexible nitrous lines must have a high-pressure rating of 1500psi as minimum.
47.5	The use of any agents other than nitrous oxide as part of or mixed with this pressurized fuel system is strictly prohibited.

	47.6	Bottle shut-off valves must be equipped with an on/off tap. Any bottles requiring a special key are not permitted. Only cylinders designed for the use and storage of nitrous oxide and that are equipped with a safety pressure valve are acceptable.
	47.7	All bottles must be securely mounted, stamped with minimum DOT-1800-pound rating, and identified as Nitrous Oxide. Nitrous Oxide bottle(s) located in the driver compartment must be equipped with a relief valve and vented outside of compartment. System must be commercially available and installed per manufacturers recommendations.
	47.8	External heating of bottle(s) with open flame is prohibited.
CR48	NIGHT LIGHTING	All vehicles racing at night are recommended to be fitted with an operative red taillight or reflective tape. (Refer to class regulations.)
CR49	NUTS AND BOLTS	The use of ultra-high tensile Allen and star head bolts of the type commonly referred to as "unbrace" in areas where lateral impact may be experienced is not permitted.
CR50	OCCUPANTS	No more than one person is permitted in any vehicle during its participating in qualifying and/or competition run-offs. Any time a vehicle is started, whether in the pits, staging lanes or anywhere else on the Racing facility, a competent driver must be in the driver's seat.
CR51	OIL CONTAINMENT DEVICE (ENGINE)	Engine diaper or catch-pan device to capture oil and debris in event of engine failure is highly recommended or mandatory for category "Modified" vehicles. (Refer to category regulations). If catch-pan device is used, the catch-pan must employ a lip of adequate height on all sides and must be curved inward, so as to contain oil.
CR52	OIL SYSTEM	Accu-sump, dry sump, oil filters, oil supply lines etc., are prohibited in the driver's compartment. Only an oil pressure gauge and line are permitted in the driver's compartment.
CR53	PARACHUTES	All parachutes to be manufactured by a recognized DRAG RACING EQUIPMENT MANUFACTURER and must be suitable sized and suitable mounted as per the manufacturer's instructions.
	53.1	(a) STOPPING DISTANCE EXCEEDING 600 METRES <ul style="list-style-type: none"> • Any car capable of exceeding 300km/h and with four-wheel brakes, <u>TWO</u> parachutes mandatory. • Any car capable of exceeding 280km/h and with two-wheel brakes, <u>TWO</u> parachutes mandatory. • Any car capable of exceeding 250km/h (and slower than 300km/h) and with four-wheel brakes, a minimum of <u>ONE</u> parachute mandatory. (Two parachutes recommended). • Any car capable of exceeding 230km/h (and slower than 280km/h) and with rear wheel brakes only, a minimum of <u>ONE</u> parachute mandatory. (Two parachutes recommended).
	53.1	(b) STOPPING DISTANCE LESS THAN 600 METRES (AND OVER 500 METRES) <ul style="list-style-type: none"> • Any car capable of exceeding 280km/h and with four-wheel brakes, <u>TWO</u> parachutes mandatory. • Any car capable of exceeding 260km/h and with two-wheel brakes, <u>TWO</u> parachutes mandatory. • Any car capable of exceeding 230km/h (and slower than 280km/h) and with four-wheel brakes, a minimum of <u>ONE</u> parachute mandatory. (Two parachutes recommended). • Any car capable of exceeding 220km/h (and slower than 260km/h) and with rear wheel brakes only, a minimum of <u>ONE</u> parachute mandatory. (Two parachutes recommended).
	53.1	(c) STOPPING DISTANCE LESS THAN 500 METRES <ul style="list-style-type: none"> • Any car capable of exceeding 260km/h and with four-wheel brakes, <u>TWO</u> parachutes mandatory. • Any car capable of exceeding 240km/h and with two-wheel brakes, <u>TWO</u> parachutes mandatory. • Any car capable of exceeding 230km/h (and slower than 260km/h) and with four-wheel brakes, a minimum of <u>ONE</u> parachute mandatory. (Two parachutes recommended). • Any car capable of exceeding 220km/h (and slower than 240km/h) and with rear wheel brakes only, a minimum of <u>ONE</u> parachute mandatory. (Two parachutes recommended).
	53.2	The Scrutineer should observe the proper operation of the chute/s and also inspect the same for worn or ragged pilot or drogue chutes.
	53.3	The parachute release cable should be mounted solidly to a frame tube or other suitable member, no further back than 25mm from the 'D' ring or release lever.
	53.4	Drag chutes must have their own independent mounting brackets and must not be mounted to the same bracket as the safety harness.
	53.5	If a safety release pin or hook is used, a clear indicator tag or flag must be attached to this item.
	53.6	Parachute deployment method: The parachute deployment mechanism shall be activated through the competitor exerting force on a lever device, which is linked directly via a cable to the parachute release system.
CR54	PARACHUTE RELEASE/RIP CORD	If the ripcord or release cable is attached to the frame or body and passes by the flywheel/clutch area, it must be enclosed in a protective steel pipe as explained in the section on BRAKES. (Article 10).

CR55 PARACHUTE USE

In all instances the 'chute' must be seen to be deployed by the end of the speed traps were considered necessary by stewards. Failure to deploy a 'chute' under competition conditions will be seen/treated as 'faulty' vehicle preparation and renders the driver liable to reprimand, or if failure continues, exclusion. The onus is on the driver to ensure the 'chute/s' is packed and maintained correctly. The Clerk of the Course may at his/her discretion ask for the parachute to be deployed during any run to satisfy himself that all parachutes are working correctly.

CR56 PINION SUPPORT

All vehicles using an open driveline must have radius arms, traction bars or some suitable pinion support to prevent rear-end housing rotation.

CR57 PROPYLENE OXIDE

The use of Propylene Oxide is prohibited in all classes/categories.

CR58 PROTECTIVE CLOTHING

- 58.1 All vehicles as per category regulations all vehicles category "Modified" together with vehicles which have fabricated or modified firewalls and/or floor (which includes wheel wells) require the driver to wear Nomex or wool one/two-piece driving suits as a minimum, plus non-flammable, balaclava, shoes and socks.
- 58.2 Vehicles in category "Pro Street", which have not been modified either in the firewall or floor areas require the driver to wear at minimum, a long-sleeved upper garment, long trousers, shoes, and socks. The wearing of short pants and/or short sleeve shirts is prohibited, and drivers are urged to wear a full overall that has been treated in the same manner as a fire blanket. (See FIRE extinguishers AND FIRE BLANKETS).
- 58.3 In both the above instances, drivers should note that "takkies" or any footwear capable of burning or melting are not permitted to be worn by any competitor while racing. No Nylon clothing is permitted under any circumstances.
- 58.4 Drivers of vehicles using Methanol as a fuel are required to wear a minimum two-layer fire resistant one piece overall or two-piece driving suit (pants and jacket). Nomex or wool socks and underwear, fire resistant boots, gloves and facemask (balaclava) are all mandatory. Onus of proof of compliance is on the entrant.
- 58.5 Drivers of vehicles using Pure Ethanol as a fuel are required to wear a minimum two-layer fire resistant one piece overall or two-piece driving suit (pants and jacket). Nomex or wool socks and underwear, fire resistant boots, gloves and facemask (balaclava) are all mandatory. Onus of proof of compliance is on the entrant.
- 58.6 Drivers of vehicles using Water Methanol Injection, irrespective of concentration are required to wear a minimum two-layer fire resistant one piece overall or two-piece driving suit (pants and jacket). Nomex or wool socks and underwear, fire resistant boots, gloves and facemask (balaclava) are all mandatory. Onus of proof of compliance is on the entrant.
- 58.7 Drivers of vehicles capable of times faster than 9.99 seconds and speeds faster than 230 kph plus all mechanically supercharged vehicles are required to wear a minimum two-layer fire resistant one piece overall or two-piece driving suit (pants and jacket). Nomex or wool socks and underwear, fire resistant boots, gloves and facemask (balaclava) are all mandatory. Onus of proof of compliance is on the entrant.

58.8 Safety Apparel & Equipment (Clothing)

Such fire-retardant clothing must be in a good condition and should ideally carry an FIA stamp of approval or one of the identification labels as listed below:-

Race Suits:

As from 2008 all local race suit manufacturers will include a permanent visible identification label on the back collar, to indicate compliance with the following approved fire-retardant fabrics and finishes:-

NOMEX	KERMAL
DIAMOND	TER
PYROVATEX	CARMYTH
AFLAMMIT	KARVIN
PROBAN	DELTA C

It's highly recommended that 100% Nomex sewing thread, or a similar flame-retardant thread is used in the manufacture of the garment for all stitching and box quilting.

LEVEL 1: Single layer one (1) piece race suit



LEVEL 2: Double layer one (1) piece race suit



LEVEL 3: Double layer one (1) piece race suit of which at least one (1) layer is comprised of Nomex / Diamond fabric



CR59 PUSH BARS

Tow or push starts not permitted. Each vehicle in competition should be equipped with a suitable bumper-height pushing attachment to facilitate emergency pushing. Push bars should be designed to prevent push car from riding up onto rear wheels of Dragster.

CR60 REAR-END

Welded spider gears in rear ends are prohibited in all categories

CR61 ROLL BAR/CAGE GENERAL REGULATIONS (refer to FIA Appendix J – Article 253)

The following regulations apply to all roll bars and roll cage specification requirements:

- 61.1 Steel tube shall be round in section and electrical resistance welded with full to penetration. Arc welding and in particular, TIG Heliarc welding preferred.
- 61.2 Welding must be free of slag and porosity whilst the process of flattening bars to necessitate joint welding is prohibited. All pipes must be notched to provide an acceptable joint where two bars meet.
- 61.3 No sleeving of roll bar/cage structure is permitted under any circumstances. All bending of pipes must be done with an approved process (e.g., Mandrel). Flush grinding of welds is prohibited.
- 61.4 All vehicles must have a 3mm sight hole drilled in relevant areas of the roll bar/cage structure to allow scrutineers to check wall thickness of tubing.
- 61.5 On enclosed vehicles (e.g., Sedans, Bakkies, Coupes, etc.) which are constructed in such a way that the body could separate from the chassis/roll cage in an accident, steel mesh or net of a maximum 75mm mesh is required to be fitted into the roll cage structure above the driver's head.
- 61.6 Threaded pipe or fittings, lap welded pipe, magnesium or aluminum pipe or tubing is not permitted.
- 61.7 On any vehicle where the standard flooring or any part of the standard structure has been removed, the roll cage must incorporate a rocker or sill bar to tie the front and rear of the cage together.
- 61.8 Any vehicle where standard flooring or any part of the standard structure has been removed or lightened (i.e., gutted), regardless of performance, must have a roll bar as a minimum requirement.
- 61.9 No material such as aluminum or copper will be allowed.

CR62 "ROLL BAR" STRUCTURAL REQUIREMENTS – ALL ENCLOSED VEHICLES

- 62.1 All enclosed OEM model-year production vehicles older than 2008 (i.e., Sedans, Bakkies, Coupes, etc.), in the True Street Car Category and Modified Car Category, capable of running faster than 12.000 seconds and slower than 10.500 seconds, or where the rear seats have been removed (refer to CR67.4), are required to fit a minimum three-point roll bar structure. All open vehicles, i.e., convertibles, sports cars, roadsters and the like, must have roll bar protection regardless of performance.
- 62.2 All roll bars must be a minimum of 42mm x 3mm wall thickness, mild steel, and be within 150mm of the rear of the driver's helmet. The main hoop must extend at least 75mm in height above the driver's helmet whilst in the normal driving position and be at least as wide as the driver's shoulders. Roll bars can be bolted together by minimum of a 10mm (GRADE 8.8) bolts with flanged supports plates.

- 62.3 The roll bar must be adequately supported to prevent forward or lateral collapse in case of a spin out, collision or upset. Braces must be of the same diameter and wall thickness as the roll bar and intersect at a point not more than 100mm from the top of the main hoop.
- 62.4 Roll bar mounting points must be securely fastened to frame or frame rails either by 10mm (8.8 grade) bolts and flanged supports or approved welding methods or by using a minimum 150mm x 150mm x 3mm steel plate on top and bottom of the floor securely bolted together with at least four 10mm or 3/8"8.8 grade high tensile bolts and nuts to sandwich the floor.
- 62.5 If the car has no frame structure, the roll bar must be fitted using a minimum 150mm x 150mm x 3mm steel plate as a foot to which each bar is welded then another steel plate of the same dimensions must be bolted under the body with at least 109mm nuts and bolts to sandwich the floor as an adequate anchorage.
- 62.6 No pop rivets or fastening bolts will be allowed for any structural support/fitting of roll bars unless it is FIA approved, or OEM fitted.

CR63 "ROLL CAGE" STRUCTURAL REQUIREMENTS – ALL ENCLOSED VEHICLES

63.1 PRO STREET CATEGORY

- 2014 – Current OEM model-year production enclosed vehicles (Euro NCAP 5 Star Rated) running quicker than 9.000 seconds are required to be fitted with a roll cage designed to protect from any angle (360°) and mounted at a minimum six points to the following minimum specifications.
- 2008 – 2013 OEM model-year production enclosed vehicles (Euro NCAP 5 Star Rated) running quicker than 10.000 seconds are required to be fitted with a roll cage designed to protect from any angle (360°) and mounted at a minimum six points to the following minimum specifications.
- Pre 2008 OEM model-year production enclosed vehicles running quicker than 10,500 seconds are required to be fitted with a roll cage designed to protect from any angle (360°) and mounted at a minimum six points to the following minimum specifications.

Convertibles running quicker than 13.499 seconds are required to be fitted with a roll cage designed to protect from any angle (360°) and mounted at a minimum six points to the following minimum specification

All vehicles older than 2008 irrespective of whether they are in full OEM trim or not that are capable of running quicker than 12.000 second-quarter mile (*7.70 eighth mile) and/or faster than 190 kph, must have a full roll cage installed refer to MSA GCR 239

ALTERED CATEGORY

- All vehicles in this category are required to be fitted with a roll cage designed to protect from any angle (360°) and mounted at a minimum six points to the following minimum specifications.

- 63.2 Main roll cage hoops – 38mm x 3mm wall thickness, mild steel, or alternatively 1 1/2" x 083" chrome moly.
- 63.3 Side/cross bars – 32mm x 2.6mm wall thickness, mild steel, or alternatively 1 1/4" x .065" chrome moly.
- 63.4 Roll cage mounting points must be securely fastened to frame or frame rails by approved welding methods, i.e., arc or preferably TIG Heliarc).
- 63.5 If the car has no frame structure the roll cage must be fitted using a minimum 150mm x 150mm x 3mm steel plate as a foot to which each bar is welded, then another steel plate of the same dimensions must be bolted under the body using at least four 10mm nuts and bolts to sandwich the floor as an adequate anchorage.

CR64 "ROLL CAGE" STRUCTURAL REQUIREMENTS – DRAGSTERS, FUNNY CARS, ETC.

- 64.1 For all Dragster, Funny car and open-wheel, space frame type vehicles, specifically designed for Drag Racing, regardless of performance, the following minimum specifications will apply to the driver's compartment.
- 64.2 Roll Cage: Vehicles weighing under 370kg may use minimum 34mm x 3mm wall thickness, mild steel, or 1 3/8 x .083" chrome moly. All vehicles over 370kg must use a minimum 38mm x 3mm wall thickness mild steel or alternatively 1 1/4 x .065" chrome moly for cage tubing. Cage must be attached to shoulder hoop at six points for Funny Cars or open wheelers and five points for Dragsters. Front of driver's helmet must be a minimum of 75mm behind the front roll cage hoop.
- 64.3 Shoulder Hoop, Top and Bottom Frame Rails, Uprights and Cross-members: A minimum 32mm x 3mm wall thickness, mild steel or alternatively 1 1/4" x .065" chrome moly.
- 64.4 Diagonals: A minimum of 19mm x 3mm wall thickness mild steel or alternatively 3/4 x .058" chrome moly.

CR65 SAFETY BELTS AND HARNESSSES

- 65.1 All vehicles regardless of performance or age must be fitted with a minimum lap/sash, three-point quick release driver's seat belt in good operating condition and complying with the South African road ordinance requirements for safety belts.
- 65.2 In all enclosed vehicle True Street Category vehicles older than 2008 (i.e., Sedans, Bakkies, Coupes, etc.) capable of running quicker than 12.00 and slower than 10.500 seconds it is advisable to have a minimum four-point safety belt/harness in good operating condition fitted for driver protection, unless a full roll cage is installed in which case a harness is mandatory.

- 65.3 All modified cars and/or all space frame vehicles specifically designed for Drag Racing, i.e., Dragsters, Funny Cars, Altered, etc., capable of running quicker than 10.500 seconds it is mandatory to have a minimum center locking, six (6) point "inverted V" type racing harness as described below.
- 65.4 In all circumstances, belts must be in good condition and securely fastened to the frame or a suitably reinforced mounting so that all fittings are in a direct line with the direction of pull. If a racing harness is installed, the applicable race seat must be installed. (refer to CR67.3)
- 65.5 If the belt mounting point requires reinforcement, a minimum 75mm x 75mm x 3mm plate must be used to adequately anchor the harness at each mounting point.
- 65.6 Under no circumstances are bolts to be inserted through belt webbing. In any vehicle requiring a roll bar as minimum structural protection, inertia reel belt/harness assemblies are not permitted.
- 65.7 All harnesses must be installed in such a manner that they will limit the travel of the driver's body, both upward and forward. Shoulder straps mounted behind the driver must be above a theoretical line of 40° down from horizontal, but not above the horizontal.
- 65.8 Protective plates are mandatory where belts wrap around any frame area exposed to potential abrasion, especially in an accident or in the event of wheel loss.
- 65.9 Belts to be worn and securely fastened at all times while the vehicle is driven and propelled by its own engine.
- 65.10 DEVICE SPECIFICS (Refer GCR 239.D)

(a) APPROVED SPECIFICATION

Only those harnesses which comply with one of the following standards will be approved by MSA for use in the specified categories:

- i 1. FIA
- ii 2. SFI

In all instances the relevant international standard / approval will be clearly indicated on the harness by means of an integral label.

FIA LABEL

The main label identifies the harness belt system and carries all information required by the FIA, i.e., Manufacturer, Last year of use and FIA homologation number. The label is sewn onto the harness belt portion permanently fixed to the buckle.

Content of the FIA homologation number

- "C" = harness restraint with 5 straps in contact with the body.
- "D" = harness restraint with 6 straps in contact with the body.
- Homologation number issued by the FIA, e.g., 136.
- "T" = for rotary buckle version (Turn)
- "P" = for push button buckle version (Push)

Digits representing the year of issue in respect to the standard the harness belt is homologated under. In terms of the above international standards only those harnesses with a minimum of 3" (approx. 75mm) shoulder straps with 2" (approx. 50mm) or 3" (approx. 75mm) waist straps are approved. In terms of the approved international standards safety harnesses with 3/4/5/6 mounting points are permitted, although it is recommended that an anti-submarine (crutch) strap be utilized. The only exception to the above specification is the combination 2" / 3" shoulder straps fitted to those FIA approved safety harnesses specifically intended for use in conjunction with the FHR head restraint system, in which case the relevant FIA label will clearly state "FOR FHR USE ONLY". It should be noted that approval of this particular harness is only valid should the product be used in conjunction with the FHR head restraint system which must be produced at scrutineering. The addition of shoulder pads is strongly recommended where the use thereof is practical within the specific application.

(b) NON-COMPLIANCE

The approval of safety harnesses that comply with the above international standards will be considered to have expired in the event of the following:

- 1. FIA approval - Date of expiry as indicated on label + 5 years
- 2. SFI approval - Date of expiry and/or manufacture as indicated on label (2years) + 2 years

The approval of safety harnesses that comply with the above international standards will no longer be approved in the event of the following: Excessive wear (fraying). or it is apparent that the safety harness has been modified from its original form or repaired in some manner. The individual safety harness components (shoulder straps / waist straps) are different colours.

(c) INSTALLATION

When installing a safety harness the manufacture installation instructions should be followed carefully so as to ensure that the performance of the product is optimized. All fittings, nuts, bolts, etc. used during the installation process must be suitable for the purpose of safety harness installation so as to allow the

harness to perform as intended. Annexure J, Article 253-42 of the FIA regulations clearly specify the correct installation procedure.

- Figure 1 shows the strap angles required for proper safety harness installation. In order to ensure correct anchorage and performance in the event of an incident it is important that these angles be met. Use of an improper anchorage or routing of any strap will reduce safety harness performance and increase the risk of serious injury or Death.

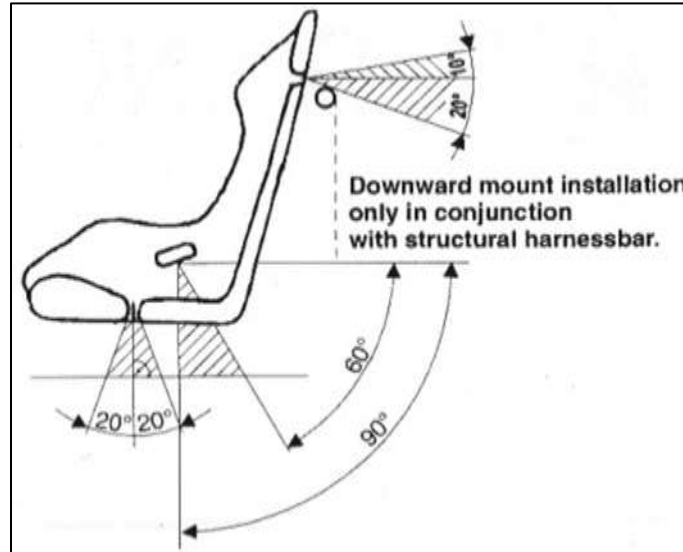

Never run the shoulder straps downwards from the backrest slots without a strap support bar which can withstand the load applied to it during a crash. The seat backrest is not designed to accommodate this load and may collapse in the event of an accident, thereby greatly increasing forward movement of the occupant which can cause serious injury or death.

An anti-submarine (crutch) strap routed towards the rear may cause serious injury during a crash as it is not designed to be a body restraint and is only intended to keep the lap belt in place during a crash so as to reduce the risk of "submarining". Similarly, the anti-submarine strap should never be run over the front line of the seat as such an installation will eliminate its intended function.

In those instances where the shoulder straps anchorage points are located more than 450mm from the rear of the backrest, it is important that the shoulder straps cross each other at the same level as that which the shoulder straps pass through the seat. Improperly installed shoulder straps may slip the shoulders during a crash and thereby increase the risk of severe head and neck injury or even death.

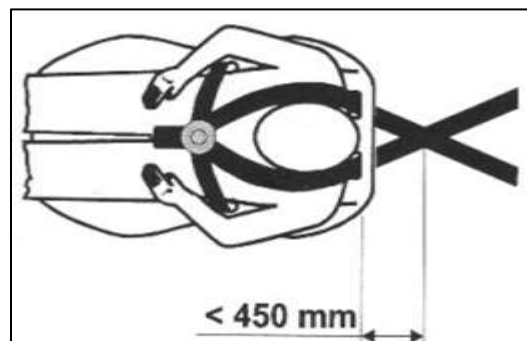

i. Eye-Bolt Installation (number)

The minimum length of an eyebolt used in the installation of a safety harness should be 25mm, ideally used in conjunction with a spring washer to secure the bolt from loosening. Always make sure that the eyebolt is positioned in the direction the belt will pull in a head on collision. Eyebolts should be tightened to a minimum torque of 40Nm using a reliable torque wrench.

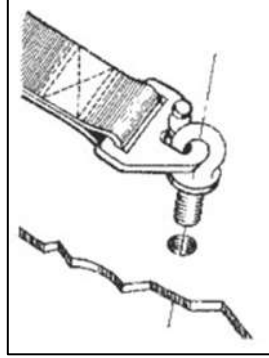

It is recommended that the anchorage points of the vehicle manufacturer be utilized wherever possible in respect to mounting of the safety harness. Any drilled anchor point must be properly reinforced to accept the load which will be applied thereto during a crash.

ii. Wrap-around Installation

Strap attachment to a weak roll cage can cause the bar to fail and result in serious injury or death. It is recommended that the roll cage manufacturer be contacted to ascertain crossbar strength and the ability thereof to withstand loads from the shoulder straps in the event of an accident.

Incorrect attachment of the strap to the adjuster can cause the belt to pull out of the adjuster in the event of an accident. Always follow the manufacturer installation instructions regarding the correct manner in which to run the strap through an adjuster when making use of a wrap-around installation.

The adjuster must be positioned as close as possible to the roll cage, and the shoulder straps should be threaded through the adjuster with the protruding strap at least 100mm long.

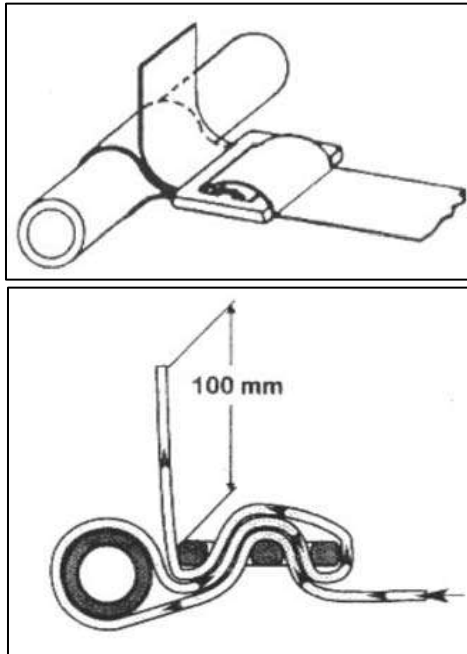

(d) NECK RESTRAINT

Neck brace is highly recommended compulsory for vehicles running quicker than 9.99 seconds. Is Highly recommended for vehicles running slower than 10.00 seconds.

CR66 SAFETY HUBS

- 66.1 All vehicles in competition, other than genuine streetcars with original engines, must be equipped with a satisfactory means of axle retention. A minimum of 3mm thick steel plate reinforcement for standard bearing retainers is required.
- 66.2 Whenever possible, approved aftermarket axles or internal safety hubs should be utilized in lieu of standard items.

- 66.3 In place of internal type safety hubs, a minimum of four hooks per driving wheel must be attached to the backing plate with a minimum of two 6mm high tensile bolts per hook.
- 66.4 Each hook must be made of 6mm minimum thickness steel plate at least 25mm width firmly mounted to retain the drum, hub, and wheel in the event of axle failure. The attention of competitors is drawn to the possibility of handling hazards in the event of an axle shaft breaking while the vehicle is fitted with a locked rear-end.

CR67 SEATING

- 67.1 The driver's seat in any vehicle in competition must be so constructed, braced, and mounted in such a way that it will give full back and shoulder protection to the driver in the event of a vehicle upset, spinout or collision.
- 67.2 The driver's seat must be supported on the bottom and back by a frame or cross member. Must not be bolted
- 67.3 Plastic kitchen-type and magnesium seats are not permitted, however, properly braced, framed, supported, and constructed seats of aluminum or fiberglass (accessory seats) are acceptable.
- 67.4 Rear seat may be removed if an approved three-point roll bar structure (half cage) is present in certain classes, or a Factory homologated seat delete kit has been installed.

CR68 SHOCK ABSORBERS

Each car in competition must be equipped with one operative shock absorber for each sprung wheel. Shocks must be either hydraulic or friction type, securely mounted and in good working order. (See class requirements).

CR69 STARTERS

All vehicles must be self-starting, other than those competing in Top Eliminator Cars or Bikes.

CR70 STEERING

- 70.1 Each vehicle's steering system will be inspected to determine its condition and must be considered safe by the scrutineer. Steering wheel "play" must be at a minimum. Drag link and tie rods must be secured and keyed. All altered or modified steering systems will be closely checked for insecure welds and faulty parts.
- 70.2 All rod ends must be a minimum 10mm shank diameter and must be installed with flat washers to prevent bearing pull out. Hollow rod ends are prohibited. All tubes into which rod ends are inserted must be drilled for thread engagement inspection.
- 70.3 The use of female Heim joints is not permitted except in the installation of rack and pinion steering where a Heim joint is used to replace the original ball joint, and no welding is involved. Any vehicle with rack and pinion steering and a beam or tube axle must have the steering mounted on the axle and incorporate a universal-joint steering shaft. The length of shaft forward of the joint must be equal to and travel through the same arc as the radius rods locating the axle.
- 70.4 All steering boxes, sectors and shafts must be mounted to the frame or suitable cross member and cannot be mounted in any case to the bell housing and/or bell housing adaptor shield.
- 70.5 On long wheelbase vehicles, a secondary steering shaft stop must be installed to prevent the long steering shaft from injuring the driver in case of frontal impact. A collar or U-joint pinned at cross member or bracket, etc. is acceptable.

CR71 STEERING WHEELS

- 71.1 A full steering wheel is required with a minimum of 300mm diameter.
- 71.2 Dragsters, Funny Cars and open-wheel, space frame vehicles designed specifically for Drag Racing may use a twin grip steering wheel having a minimum inside width of 180mm across the grips.
- 71.3 Commercially available quick-disconnect steering wheels are permitted, subject to approval by the "Scrutineers"

CR72 SUPERCHARGERS

- 72.1 All vehicles equipped with belt driven superchargers must have a guard fitted to prevent fuel line damage in the event of belt loss. This is not required where steel braided hose is used in conjunction with aircraft quality connections or where lines themselves are shielded.
- 72.2 All superchargers used in competition must be correctly set up for high performance use incorporating heavy-duty components applicable to Drag Racing requirements.
- 72.3 Types:
 - 72.3 Roots-type:
 - .1 Maximum size permitted 14-71; 482.6mm maximum rotor case length; 285.75mm maximum case width; 6.35mm minimum case thickness; 6.35mm minimum front plate thickness. 300 minimum rear plate thickness. Maximum rotor cavity diameter is 148.34mm. Rotor helix angle may not exceed that of a standard 71-series GM-type rotor (4° per 25.4mm). Maximum overdrive may not exceed 70%.
 - 72.3 Roots-type High Helix:
 - .2 Must adhere to the same maximum case dimensions and maximum rotor cavity diameter as standard Roots. Rotor helix angle may not exceed 6.5° per 25.4mm, (123.5° total over 482.60mm maximum rotor length). Maximum overdrive may not exceed 70%.
 - 72.3 Screw-Type:
 - .3 Must meet SF1 Spec 34.1. Maximum case length 406.40mm, maximum case width 406.40mm, minimum case and front plate thickness 6.35mm, minimum rear plate thickness 7.62mm. Manifold pressure release mechanism (in addition to burst panel in supercharger) plus supercharger restraint system is mandatory. Under no circumstances may a screw supercharger overdrive exceed the following overdrive limits:

ENGINE DISPLACEMENT	MAXIMUM OVERDRIVE	
	WHIPPLE	PSI
8194 CUBIC CENTIMETRES OR LARGER	1.60	2.25
7375 - 8193 CUBIC CENTIMETRES	1.52	2.15
LESS THAN 7375 CUBIC CENTIMETRES	1.44	2.04

72.3 Variable multi-speed supercharger devices are prohibited regardless of the supercharger type.

.4

72.3 Aluminum studs (supercharger to manifold) are mandatory on all superchargers.

.5

72.3 Supercharger restraint systems are mandatory.

.6

CR73 SUPERCHARGER RESTRAINTS

73.1 All belt-driven supercharger devices must have as a minimum, a supercharger restraint system in conjunction with aluminum shear bolts (strip studs) at all mounting points as mandatory to prevent the supercharger from being blown free of the engine.

73.2 All vehicles competing in Top Fuel, Top Fuel Funny Car or Top Fuel Competition Altered must be fitted with a ballistic supercharger protection device meeting SF1 specification 14.2.

CR74 SUSPENSION

74.1 All vehicles must have a full suspension of the type produced by automobile manufacturers, i.e., springs, torsion bars, etc.).

74.2 Rigid-mount front/rear axles are permitted when so indicated by class requirements. Where more than one pair of radius rods are used to locate a front axle, rods must be of the same length.

74.3 Traction bars or other devices used to transmit rear-axle torque to the frame, thus preventing violent rear-spring "wind-up" under acceleration or deceleration, are considered safety equipment, and are therefore accepted where category permits. Traction devices, if used, may not be longer in overall length than one-half of the wheelbase of the vehicle on which they are installed. No portion of any traction device may extend lower than the level of the lower edge of the rear rim.

74.4 All rod ends (steel minimum) incorporated into either a "ladder bar" or "four link" suspension system must have a minimum M20 shank diameter (chrome moly 16mm). Rod ends must thread a distance at least equal to 1.5 times the diameter of the shank into the bars they are inserted. Each bar must be drilled to allow for thread engagement inspection and either a strap or some other means of prevention must be attached at the front of both the "ladder bar" and/or "four link" system to stop them coming into contact with the track if the rod ends fail.

CR75 THREAD ENGAGEMENT INSPECTION HOLE

All bars which incorporate the use of rod ends must have a 3mm inspection hole drilled a minimum of 1.5 times the rod-end shank diameter along the bar to allow scrutineers to check for adequate thread engagement.

CR76 THROTTLE LINKAGE

Regardless of class, each vehicle must have a foot throttle incorporating a positive-acting return spring attached directly to the carburetor throttle arm. A positive stop or over-ride prevention must be used to keep linkage from passing over centre and sticking in an open position. In addition to return springs, some means of manually returning the throttle to a closed position by use of the foot must be installed on all vehicles using any other than standard or altered linkage system. All vehicles fitted with superchargers/blowers must have some means of returning the throttle to a closed position by use of the foot. Choke cables and brazed or welded fittings on steel cable are not allowed.

CR77 TOWING RING/HOOK

All cars must have some kind of towing ring, tow strap or hook affixed to the front of the vehicle so as to help reduce the time required to clear the track should a vehicle failure occur.

CR78 TOW VEHICLE

Any vehicle used as a tow car must have the competition number displayed prominently on the windscreen. Crew members must be inside the cab or completely inside the bed of the truck. Nobody is to be seated on the tailgate, standing on running boards or otherwise. They are all to be seated completely inside the vehicle.

CR79 TRACTION CONTROL

Is permitted

CR80 TRANSMISSION

80.1 All vehicles in competition must be equipped with reverse gear.

80.2 Air shifter bottles must be stamped with Dot-1800-pound rating (minimum) and be securely mounted, i.e., no tie-wraps or hose clamps.

CR81 TYRES

81.1 Tyres will be visually checked for condition, pressure, etc. and must be considered safe by the scrutineer prior to any runs by the vehicle. Implement tyres are prohibited and all street tyres must have a minimum of 1mm tread depth over 100% of the tread area at the completion of the day's racing.

81.2 All street tyres must be Dot approved with grooves made by the tyre manufacturer.

- 81.3 All vehicles capable of exceeding 260km/h are required to have front tyres specifically built for Drag Racing use, i.e., Goodyear or Mickey Thompson Front Runners etc.)
- 81.4 Any make or type of road tyre, racing tyre or drag slick (see class requirements) is permitted on vehicles slower than 260kph provided the speed rating of the tyre is adequate for that particular vehicle's performance.
- 81.5 Under no circumstances will re-threaded/remolded tyre be allowed on any vehicle.
- 81.6 Either steel or good condition rubber valve stem caps are required on all wheels and tyres.
- 81.7 Tyre pressure should be as per manufacturer's recommended pressure guidelines, but Street Tyres should not be below 1,5 bar.
- 81.8 Dot approved tyres with no grooves will be classified as slicks.
- 81.9 Tyre pressures below 1.0 bar (14.5 PSI) may only be permitted on a rim fitted with a bead lock.

CR82 VENT TUBES/BREATHERS

Mandatory on all Top Eliminator vehicles and accepted in all other classes. Where used, the tubes must terminate into an acceptable, permanently attached catch-tank with a capacity of four litres per engine. The catch-tank must be able to keep over-flow off the track, and a sight glass or tube is recommended to verify that tank is empty prior to each run.

CR83 WEIGHT

- 83.1 All weights are applicable after a vehicle has completed a run and must include driver.
- 83.2 All Drag Racing venues (when and where applicable) must have available for the duration of a race meeting, a suitable weighing facility in accordance with the requirements of the Drag Racing Commission.
 - 83.2.1 Current certification and/or assessment certificate(s) must be present with the promoters.
 - 83.2.2 Suitable test weigh/s must be available.
 - 83.2.3 The scale/s present on the day shall at the discretion of the Clerk of Course be deemed correct.
 - 83.2.4 The weighing and measuring devices used by the event officials shall be the standards that will determine a vehicle's compliance with the rules.
 - 83.2.5 It is the onus of the competitor to ensure that his/her vehicle is weighed by officials if/when applicable to ensure their vehicle complies with the correct weights as laid out in the MSA Drag Racing Handbook for the current year e.g.:
 - After every record-breaking run,
 - To class a vehicle, when necessary, prior to the start of the days racing and,
 - Prior to first round of eliminations if a competitor has dialed on the record.

83.3 MINIMUM WEIGHTS

83.3.1 SEDAN CARS (RE: MODIFIED STREET, MODIFIED RACE, STREET CARS, ETC.)

a. INTERNAL COMBUSTION ENGINES (excluding Rotaries)

i. Up to 2600cc Engine Capacity

FRONT WHEEL DRIVE

- Normally Aspirated - 730kg
- One Power Adder - 820kg
- Two Power Adders - 910kg

REAR WHEEL DRIVE

- Normally Aspirated - 840kg
- One Power Adder - 870kg
- Two Power Adders - 960kg

ALL WHEEL DRIVE

- Normally Aspirated - 840kg
- One Power Adder - 870kg
- Two Power Adders - 960kg

ii. Over 2600cc Engine Capacity

- ALL VEHICLES - 1000kg

b. ROTARY ENGINES

- Normally Aspirated - 840kg
- One Power Adder - 950kg
- Two Power Adders - 1000kg

iii. Light Weight Factory Manufactured

- All factory manufactured lightweight roadsters, such as a >730kg (subject to verification of OEM weight by the Scrutineers)

“Lotus 7, Atom are permitted in OEM production form, and it is understood that these vehicles will weigh under 730kg.

CR84 WEIGHT DISTRIBUTION

- 84.1 Each vehicle must have an adequate percentage of its weight carried on the front wheels to ensure proper handling ability at all times. Additional front-end weight will be required by the scrutineer on vehicles experiencing excessive wheel stands or carrying the front wheels during acceleration.
- 84.2 Weight Distribution on FWD vehicles
On FWD vehicles special notice needs to be taken of the weight distribution of the vehicle for safety reasons. On de-acceleration or braking, a vehicle that is very light in the rear can become unstable and/or lock the rear wheels during hard braking.
If the weight distribution (percentage) Front to Rear, of a vehicle falls into the range of (F) 70 (R) 30 to (F) 80 (R) 20, a Parachute is mandatory as a supplementary brake-system regardless of speed attained.
If the weight distribution Front to rear, is equal to or greater than (F) 80(R) 20, a parachute AND independently braked rear wheels are mandatory, regardless of speed attained.

CR85 WHEELBASE

Minimum wheelbase is 2.20 meters. Maximum wheelbase variation from left to right is 50mm. Refer to individual class requirements.

- 85.1 Cars
- All vehicles (except Factory Street) running under 11.999 and not quicker than 10.000, 2.2 meter minimum (Engine swap allowed).
 - All vehicles (except Factory Street) running 9.999 and quicker, 2.3 meter minimum (Engine swap allowed).

Note: Further restrictions and/or allowances may also apply, refer to individual category requirements.

CR86 WHEEL WELLS:

See Class Requirements.

CR87 WHEELS

- 87.1 All hubcaps must be removed. Scrutineers must check for loose lugs, cracked wheels, worn or oversize lug holds, spindles, axle nuts, cotter pins, etc. Snap-on hubcaps are not permitted on any class of vehicle during competition. Stock mag wheels may use lug nuts as supplied from the factory.
- 87.2 Each vehicle must be equipped with automotive-type wheels with a minimum diameter of 325mm unless class regulations state otherwise. Rim width for enclosed, i.e., Sedan, bakkie, Coupe, etc. vehicles must be a minimum of 75mm in width.
- 87.3 Motorcycle rims or lightweight automotive wire wheels acceptable on front of Dragster only, provided total weight of vehicle does not exceed 900kg including the driver. Each wire rim must be equipped with 3mm minimum diameter steel spokes properly cross-laced to provide maximum strength. All available spoke holes in rim and hub must be laced, and omissions to lighten wheels are not permitted.
- 87.4 Where it can be established that a “beam breaker” shield is required on wire rims, it is mandatory for a competitor to securely and permanently fit a device to clearly cut the start line staging beams before entering a competition.
- 87.5 Maximum rim width on any vehicle is 406mm.
- 87.6 No rear wheel discs or covers permitted in any category and the use of sports car or automotive wire wheels is restricted to vehicles to which they were originally fitted.
- 87.7 Either steel or good condition rubber valve stem caps are required on all wheels.

CR88 WHEEL STUDS

A wheel stud must protrude from the outer face of the wheel by a distance at least equal to the diameter of the stud. Scrutineers are required to check the fit by removing at least one lug nut on each rim if it is not readily recognizable that the stud extends through the rim far enough. The wheel nut may not be encapsulated.

CR89 WHEELIE BARS

Wheelie bars are permitted as per category regulations. Wheels must be non-metallic. Wheelie-bar wheels must turn freely at starting line; any preload is prohibited. Wheelie bars must be fixed. Hydraulics, pneumatics, electronics, etc. or any adjustment or movement during run is prohibited. Using wheelie-bar wheels as “fifth wheel” sensing device is prohibited.

CR90 WINDOW NETS

- 90.1 All enclosed vehicles with doors, i.e., Sedans, Bakkies, Coupes, etc.), requiring the use of a “roll cage” must be fitted with a driver-side ribbon-type window net with minimum dimensions of 450mm x 600mm or alternatively properly adjusted arm restraints.
- 90.2 Net must be attached to the inside of the roll cage top bar and also to the intrusion bar. The net must be permanently attached at the bottom either by hose clamping to the intrusion bar or some other acceptable method whilst the top must be clipped at each end to eyebolts or a seat belt-type fastener. Chief start line Marshall must

ensure competitors have net or restrains correctly fastened before going into stage. Rubber shock cords are not acceptable for mounting net.

CR91 WINDSCREENS AND WINDOWS

- 91.1 On open bodied vehicles, a metal, plastic, or Plexiglas deflector must be installed to divert wind, liquids, foreign matter, etc., over the driver's helmet. The wind deflector must be securely mounted and installed in such a manner that it does not in any way obstruct the driver's frontal view.
- 91.2 Windshields, when called for in class requirements, must be safety glass, Plexiglas, or other shatterproof material. The front screen must be clear, without tinting or coloring except factory-tinted safety glass.
- 91.3 Tinting of side windows cannot be such as to prevent visibility of driver through side windows at night events. Where Funny Cars have full side windows fitted, a 150mm diameter opening must be provided to facilitate access from the outside.

CR92 WHEEL TUBS

Wheel tubs are only permitted in Competition Altered vehicles

PRO STREET CAR

This category of drag racing vehicle is mainly for Championship drag racing events taking place at various venues such as graded tracks that are sanctioned by MSA and consist of timing equipment capable of running both with and without Handicap Racing.

The drag racing dynamic in South Africa is very different to other countries in that we do not have a wide range of purpose-built drag racing vehicles that compete in any of the regulated drag racing series and competition on a regular basis. Pro-mod, Altered and Competition Altered vehicles do exist but are a small percentage of the everyday racing scene. The fact of the matter is that there are simply not enough of these vehicles in every region to run a separate competition based on these vehicle category and class combinations.

The dominant category of vehicle at drag racing events is an OEM production type vehicle where engine upgrades have taken place, but the vehicle remains mostly "Street Legal". Over the years the term "Street Legal" has been stretched to the limit, and in line with the NHRA's dispensation for OEM production type vehicles in their revised 2023 Rule Book, Motor Sport South Africa has adopted the Streetcar guidelines.

This category is amended to cater for the "Street Legal" vehicles and is reserved for foreign and domestic OEM production type automobiles, and SUVs and LDVs. All vehicles must be street driven and drivers must carry a valid South African vehicle registration and licensing certificate (disc). For a vehicle to be categorized in the Pro Street Category, the vehicle must pass all stipulations of the South African National Road Traffic Act 93 of 1996 and retain all OEM safety features, therefore making it legal to operate on a public road. Engines component upgrades are permitted, but the swapping of engines to one that is different in specification to the unit supplied in the OEM production model is prohibited. The drivetrain, other mechanical components and tyres may be upgraded or strengthened in accordance with category requirements.

Bolt on modifications are allowed, including but not limited suspension, brakes, forced induction, exhaust, DOT Drag Radials and etc., but absolutely no cutting or sectioning of the chassis permitted, including but not limited to frame/unibody construction, including floors and firewall. All OEM safety-related systems must be functioning as per manufacturer's specifications.

This category will restrict the Elapsed Time (ET) of participating vehicles as follows:

- 2014 – Current OEM model-year production (EURO NCAP 5 RATED) enclosed vehicles are permitted to run no quicker than 9.000 second-quarter mile (*5.65 eighth mile) and/or faster than 240 kph, without the need for a roll-cage.
- 2008 – 2013 OEM model-year production (EURO NCAP 5 RATED) enclosed vehicles are permitted to run no quicker than a 10.000 second-quarter mile (*6.40 eighth mile) and/or no faster than 216 kph, without the need for a roll-cage;
- Pre 2008 OEM model-year production enclosed vehicles are permitted to run no quicker than a 12.000 second-quarter mile (*7.70 eighth mile) and/or no faster than 190 kph, without the need for a roll-cage.
- Convertibles quicker than 13.499 seconds-quarter mile (*8.25 eighth mile) and T-tops quicker than a 11.499 second-quarter mile (*7.35 eighth mile) must meet the rollbar and roll-cage requirements.
-

All vehicles older than 2008 irrespective of whether they are in full OEM trim or not that are capable of running quicker than 12.000 second-quarter mile (*7.70 eighth mile) and/or faster than 190 kph, must have a full roll cage installed, Refer to MSA GCR 239

PRO STREET CATEGORY consists of Street Legal 12,10,8,6,5,4,3-cylinder internal combustion engine vehicles, Electric Vehicles (EV) – Front wheel drive, Rear wheel drive and All wheel drive – Normally Aspirated, one form of supercharging and Rotary's.

MINIMUM WEIGHTS				
SEDAN CARS (RE: MODIFIED STREET, MODIFIED RACE, STREET CARS, ETC.)				
	a.	INTERNAL COMBUSTION ENGINES (excluding Rotaries)		
		i.	Up to 2600cc Engine Capacity	
			FRONT WHEEL DRIVE	
		-	Normally Aspirated	730kg
		-	One Power Adder	820kg
		-	Two Power Adders	910kg
			REAR WHEEL DRIVE	
		-	Normally Aspirated	840kg
		-	One Power Adder	870kg

		- Two Power Adders	-	960kg
		ALL WHEEL DRIVE		
		Normally Aspirated	-	840kg
		One Power Adder	-	870kg
		Two Power Adders	-	960kg
	ii.	<u>Over 2600cc Engine Capacity</u>		
		ALL VEHICLES	-	1000kg
	b.	<u>ROTARY ENGINES</u>		
		- Normally Aspirated	-	840kg
		- One Power Adder	-	950kg
		- Two Power Adders	-	1000kg
	iii.	<u>Light Weight Factory Manufactured</u>		
		All factory manufactured lightweight roadsters, such as a "Lotus 7, A are permitted in OEM production form, and it is understood that these vehicles will weigh under 730kg.		>730kg (subject to verification of OEM weight by the Scrutineers)

ALTERED CAR CATEGORY

This category is reserved for four wheeled, altered / modified production model vehicles, designed only for drag racing. For altered / modified production bodies the basic standard appearance is to be maintained, engine, driveline, chassis etc., may be altered, modified, as outlined in the category requirements.

These vehicles would typically not be able to pass all stipulations of the South African National Road Traffic Act 93 of 1996 and would not retain all OEM safety features, thus would not be legal to drive on a public road.

**If the circuit is not suitable, these classes of vehicles will be restricted to solo runs over a (1/4) quarter mile, but can race heads-up over an (1/8) eighth mile

MINIMUM WEIGHTS			
SEDAN CARS (RE: MODIFIED STREET, MODIFIED RACE, STREET CARS, ETC.)			
	a.	INTERNAL COMBUSTION ENGINES (excluding Rotaries)	
		i.	Up to 2600cc Engine Capacity
			FRONT WHEEL DRIVE
		-	Normally Aspirated - 730kg
		-	One Power Adder - 820kg
		-	Two Power Adders - 910kg
			REAR WHEEL DRIVE
		-	Normally Aspirated - 840kg
		-	One Power Adder - 870kg
		-	Two Power Adders - 960kg
			ALL WHEEL DRIVE
			Normally Aspirated - 840kg
			One Power Adder - 870kg
			Two Power Adders - 960kg
		ii.	Over 2600cc Engine Capacity
			ALL VEHICLES - 1000kg
	b.	ROTARY ENGINES	
		-	Normally Aspirated - 840kg
		-	One Power Adder - 950kg
		-	Two Power Adders - 1000kg
		iii.	Light Weight Factory Manufactured
			All factory manufactured lightweight roadsters, such as a "Lotus 7, A are permitted in OEM production form, and it is understood that these vehicles will weigh under 730kg.
			>730kg (subject to verification of OEM weight by the Scrutineers)

ARTICLE – ALTERED CAR (AC) – REQUIREMENTS AND SPECIFICATIONS

A – ENGINE	
MR 1	BATTERY: (Refer to the Safety Regulations)
MR 2	COOLING SYSTEM: (Refer to the Safety Regulations)
MR 3	ENGINE
	Must be of an internal combustion type, but capacity, make, model and year are free. Any modification may be made to the engine. Maximum engine set back must not exceed 10% of the wheelbase as measured from the front wheel centre line to the forward most spark plug position.
MR 4	ENGINE RELOCATION
	Relocation of the engine is not permitted; i.e. front engine cars may not be converted to rear engine cars and vice versa.
MR 5	EXHAUST: (Refer to the Safety Regulations)
	An open exhaust is permitted. Split manifolds, branches or individual pipes are permitted provided they are permanently and securely attached with a metal connecting strap to prevent loss.
MR 6	FUEL
	Any fuel complying with general regulations. Ethanol and Methanol is permitted. The use of professionally installed Water Methanol Injection systems is permitted. The use of Nitromethane as fuel or separate injection is strictly prohibited. (Refer to Safety Regulations)
MR 7	FUEL SYSTEM AND FUEL TANKS
	Accessory tanks may be fitted, and fuel blocks can be used. Any type of mechanical and/or electrical pumps may be used. (Refer to the Safety Regulations)
MR 8	LIQUID OVERFLOW/CATCH TANKS
	Catch tanks must be fitted and be completely leak-proof and must be securely mounted to a chassis member.
MR 9	NITROUS OXIDE
	The use of Nitrous oxide is permitted. (Refer to the Safety Regulations)
MR 10	OIL CONTAINMENT DEVICE: (Refer to Safety Regulations, CR 51)
MR 11	RADIATOR AND GRILLE
	The Radiator is optional. Grilles are required either in original, painted or fabricated form. The replacements must at least be as large as the original frontal area. Reduction in height or frontal area is not permitted.
B – DRIVETRAIN	
MR 12	DIFFERENTIAL
	Differential may be upgraded with performance components, such as limited slip differentials (LSD). Narrowed rear-ends are not acceptable and locked rear-ends are not permitted. (Refer to the Safety Regulations regarding “axle retention”). Front wheel drive cars (as per OEM) may not be converted to rear-wheel-drive cars and vice versa.
MR 13	FLYWHEEL/FLYWHEEL SHIELDS: (Refer to the Safety Regulations)
MR 14	REAR END
	Welded spider gears are not permitted. Front drive cars may be converted to conventional rear-wheel drive (Front Engine). Quick change, limited slip or spooled differential assemblies are permitted. The attention of competitors is drawn to the possibility of handling hazards in the event of an axle shaft breaking while the vehicle is fitted with a “locked” rear-end. Four-wheel drive is permitted. (Refer to the Safety Regulations)
MR 15	TRANSMISSION
	Aftermarket or production automobile transmissions of any year, make, model or ratio are permitted in all classes. Operative reverse gear is required. Transmission must remain in conventional location determined by the engine used. All gearshift levers (if used) must be topped with a ball or blunt handle. (Refer to the Safety Regulations)
C – BRAKES AND SUSPENSION	
MR 16	BRAKES
	All vehicles in this category must be equipped with four-wheel hydraulic brakes operated by a foot-mounted pedal in the conventional manner. Aftermarket performance brake rotors and pads may be used, as long as the size of the rotor is not smaller than the OEM specification. A back-up brake system is mandatory on all vehicles, i.e. handbrake. (Refer to Safety Regulations)
MR 17	SUSPENSION FRONT
	Full automotive-type front suspension is required. No solid axles allowed. Each point of suspension must be equipped with at least one effective shock absorber with a minimum of 25mm movement in each direction. Cutting or machining of suspension parts is prohibited. Raising or lowering permitted but attention must be taken of minimum ground clearance requirements. A minimum of one hydraulic or pneumatic shock absorber is required per wheel, and rear suspension must be operative automobile type.
MR 18	SUSPENSION REAR
	Aftermarket and/or fabricated four-link and/or ladder bar type suspension is permitted. Back halving is permitted. (Refer to the Safety Regulations)
MR 19	STEERING
	Properly fitted rack and pinion steering may be used in lieu of standard steering. Steering units may be relocated and/or substituted. (Refer to the Safety Regulations)
MR 20	WHEELIE BARS

	Wheelie bars are permitted. (Refer to the Safety Regulations)
MR 21	TRACTION BARS: (Refer to the Safety Regulations)
D – FRAME	
MR 22	BALLAST: (Refer to the Safety Regulations)
MR 23	CHASSIS
	The chassis from radiator to rear of vehicle may be totally or partially replaced. Any properly reinforced frame is accepted. Additional members may be added for strength and/or roll cage installation. (Refer to the Safety Regulations). The frame may be modified to fit any alternative engine/gearbox/differential units.
MR 24	ROLL BARS/ROLL CAGES: (Refer to the Safety Regulations)
	A roll cage is mandatory in this category irrespective of ET (Refer to the Safety Regulations)
MR 25	WHEELBASE
	Wheelbase must not be altered more than 5% from standard measurement. All vehicles in these classes may not have a wheelbase variance from left to right of more than 25mm measured from centre of front wheel to centre of rear wheel.
	25.1 All vehicles running 8.99. and quicker, 2.3 meter minimum.
	25.2 Wheelbase may not be shortened more than 1% from original.
	25.3 Wheelbase may not be extended more than 5% from original.
	25.4 Maximum wheelbase variance of 25mm from left to right (measured from centre of front wheel to centre of rear wheel).
MR 26	PARACHUTE: (Refer to the Safety Regulations)
D – TYRES AND WHEELS	
MR 27	WHEELS/TYRES
	All tyres must have sufficient clearance to allow for body movement and a minimum of 100mm all-round must be allowed for tyre growth. Magnesium and other alloy racing wheels are permitted. Any type of road tyre or slick is permitted providing the speed rating is adequate for the vehicle performance. (Refer to the Safety Regulations)
MR 28	WHEELS TUBS
	Wheel wells or tubs may be enlarged or replaced to allow use of larger rear tyres. If new wheel wells are constructed, they shall completely cover the inside and top 180° of the wheel and tyre and also completely isolate the driver compartment.
E – INTERIOR	
MR 29	INTERIOR TRIM
	The removal of trim panels, carpets, hood linings and all other OEM trim is permitted.
MR 30	INSTRUMENTS
	Dashboard instruments may be installed at the owner's discretion.
MR 31	SEATS: (Refer to the Safety Regulations)
MR 32	SAFETY HARNESS: (Refer to Safety Regulations)
MR 33	UPHOLSTERY
	Upholstery is optional but where used, must be of fireproof material.
F – BODY	
MR 34	AEROFOIL
	This must be securely mounted. If adjustable, a positive locking device must be used to prevent accidental movement.
MR35	BALLAST
	(Refer to the Safety Regulations)
MR 34	BODY
	34.1 Must be a production car body with at least two driver exit or entry points. Bodies may be altered in height to a maximum of 100mm but not in width, length, or contour. Streamlining must not change the outward appearance of the vehicle. Bumpers are not required. Sedan, coupe, convertibles, roadsters, panel vans and bakkies may all compete in this class providing all requirements are met.
	34.2 The use of fiberglass, carbon fibre or aluminum replacement panels is acceptable providing the vehicle's standard appearance is retained. Body set back must not exceed 10% of the original wheelbase as measured from rear axle to centre of the original wheel well location. Rear wheel wells may be altered for clearance to permit the use of larger tyres, but new edges must be adequately beaded.
	34.3 Replacement floors are permitted providing a cross member of a minimum 50mm x 3mm wall thickness is installed between the frame rails for adequate driver's seat and harness anchoring.
	34.4 In certain instances a steel or aluminum floorboard may be substituted with a Carbon Fibre or Kevlar panel, for example FWD vehicles with tubular rear sub-frame/suspension for coverage. Refer to CR18, 26.
	34.5 All vehicles are required to fit a bonnet of standard appearance through which bonnet scoops, injector tubes or superchargers are permitted to extend. Scoop must not exceed 300mm in height as measured from the base of the scoop.
MR 35	STREET EQUIPMENT
	Alternator, windshield, wipers, fans, fan belts, horns, etc., are optional. Headlights must be original size and in original location but need not be operative. Painted or simulated headlights are permitted however a minimum of one operative red taillight is required for night events.
MR 36	BUMPERS
	Bumpers may be removed. Fiberglass bumpers and lightweight mountings are permitted.

MR 37	FIREWALL
	Mandatory. (Refer to the Safety Regulations)
MR 38	WINDSCREENS AND WINDOWS
	38.1 A windscreen must be fitted on all vehicles. Minimum height of front screen is 125mm as measured vertically. All windscreens must be transparent, clear and in good condition. Other than factory tint, all front screens must be clear.
	38.2 Plexiglas, Lexan or Poly Carbonate may be used provided it is of sufficient thickness to not flex at speed, and it complies with the above conditions. The placing of advertising or other decals on either the front windscreen or front side windows must be restricted to a maximum of the top or bottom 10% of the area so as not to obstruct the visual passage of the driver.
G – ELECTRICAL	
MR 39	BATTERY
	(Refer to the Safety Regulations).
MR 40	ELECTRICAL
	Each vehicle in this section must have a full working wiring harness, but the harness may be safely modified from OEM specification. All lights and charging systems must be fully operational. Starter motor must be retained.
MR 41	IGNITION SYSTEM
	Any ignition may be used
MR 42	INSTRUMENTS
	Dashboard instruments may be installed at the owner's discretion.
MR 43	STARTERS
	Self-starting is required. Push starts are not permitted.
H – SUPPORT GROUP	
MR 44	FIRE EXTINGUISHER
	A minimum of 1,5kg capacity fire extinguisher is mandatory, securely mounted (no tie straps), and within easy reach of the driver when he/she is wearing a safety harness is mandatory. (Refer to Safety Regulations)
I – DRIVER	
MR 45	DRIVER
	The driver's body must be completely isolated from the driveline, differential and wheels by suitable non-flammable body panels. The seat may be relocated a maximum of 200mm back from the standard position and must be mounted either left or right of the centre line.
MR 46	HEAD PROTECTION: (Refer to the Safety Regulations)
MR 47	PROTECTIVE CLOTHING: (Refer to Safety Regulations)
MR 48	HELMETS: (Refer to Safety Regulations)
MR 49	GOGGLES: (Refer to Safety Regulations)

STREET TO STRIP DRAG RACING

This category of drag racing is solely for non-championship events, “Street to Strip” or “Illegal to Legal” drag racing events-taking place at various venues such as graded tracks that are sanctioned by MSA. This category is racing held to promote safety and encourage drivers/riders to bring their daily driven/ridden street vehicles to a circuit and discourage illegal street racing. The use of slick or drag radials are strictly prohibited. Category Modified vehicles will not be allowed in street to strip drag racing events due to safety reasons.

This category has been introduced to cater for basically stock vehicles strictly in full street trim, with street tyres. It is reserved for vehicles based on normal production models with a factory produced automotive-type engine. The body, drive train, chassis and other components may not be altered or modified. This category-must run heads up as individual classes. The minimum cut off in this category is 10.000 seconds and the maximum will be > 14.000 seconds over a (1/4) quarter mile. Any vehicle/s running quicker than 10.000 seconds, will be prohibited from any further runs due to safety reasons. Any circuit that is hosting street to strip events must have timing equipment capable of monitoring competitors to ensure that the 10.000 second ET cutoff is enforced and adhered to.

CLASSES: There are (25) twenty-five classes of competition determined as follows:	
8 CYLINDERS	
8A	Any 8-cylinder normally aspirated.
8B	Any 8-cylinder with one form of supercharging (i.e. turbo or nitrous or supercharger)
8C	Any 8-cylinder fitted with two forms of supercharging (i.e. turbo/nitrous, supercharger/nitrous).
8AWD	Any 8-cylinder [AWD] with one forms of supercharging (i.e. turbo/nitrous, supercharger/nitrous).
6 CYLINDERS FRONT AND REAR WHEEL DRIVE	
6AF	Any 6-cylinder [FWD] normally aspirated
6BF	Any 6-cylinder [FWD] with one form of supercharging (i.e. turbo or nitrous or supercharger)
6CF	Any 6-cylinder [FWD] with two forms of supercharging (i.e., turbo/nitrous, supercharger/nitrous).
6AR	Any 6-cylinder [RWD] normally aspirated
6BR	Any 6-cylinder [RWD] with one form of supercharging (i.e., turbo or nitrous or supercharger)
6CR	Any 6-cylinder [RWD] with two forms of supercharging (i.e., turbo/nitrous, supercharger/nitrous).
6AWD	Any 6-cylinder [AWD] with one forms of supercharging (i.e., turbo/nitrous, supercharger/nitrous).
5 CYLINDERS FRONT AND REAR WHEEL DRIVE	
5AF	Any 5-cylinder [FWD] normally aspirated
5BF	Any 5-cylinder [FWD] with one form of supercharging (i.e., turbo or nitrous or supercharger)
5CF	Any 5-cylinder [FWD] with two forms of supercharging (i.e., turbo/nitrous, supercharger/nitrous).
5AR	Any 5-cylinder [RWD] normally aspirated
5BR	Any 5-cylinder [RWD] with one form of supercharging (i.e., turbo or nitrous or supercharger)
5CR	Any 5-cylinder [RWD] with two forms of supercharging (i.e., turbo/nitrous, supercharger/nitrous).
5AWD	Any 5-cylinder [AWD] with one forms of supercharging (i.e., turbo/nitrous, supercharger/nitrous).
4 CYLINDERS FRONT AND REAR WHEEL DRIVE	
4AF	Any 4-cylinder [FWD] normally aspirated
4BF	Any 4-cylinder [FWD] with one form of supercharging (i.e., turbo or nitrous or supercharger)
4CF	Any 4-cylinder [FWD] with two forms of supercharging (i.e., turbo/nitrous, supercharger/nitrous).
4AR	Any 4-cylinder [RWD] normally aspirated
4BR	Any 4-cylinder [RWD] with one form of supercharging (i.e., turbo or nitrous or supercharger)
4CR	Any 4-cylinder [RWD] with two forms of supercharging (i.e., turbo/nitrous, supercharger/nitrous).
4AWD	Any 4-cylinder [AWD] with one forms of supercharging (i.e., turbo/nitrous, supercharger/nitrous).

JUNIOR REGULATIONS

JUNIOR CLASS CARS	
Status	Regional and Club Status
1.	<p>Age Restrictions and Junior Car Categories (Adapted from the NHRA Junior Drag Racing Regulations 2024)</p> <p>Intermediate and Advanced category may compete in Club and Regional Status events only.</p> <p>All Junior competitors must submit a certified birth certificate on all new licence applications. Subsequent renewals do not require resubmission of certified birth certificate. Willfully falsifying an MSA licence and/or participation documents for any reason including avoiding age restrictions will be grounds for denial of license, suspension or revocation of license, or other action deemed appropriate by MSA in MSA's sole and absolute discretion, including but not limited to exclusion from all MSA permitted events. Driver must be the minimum age for the Age Group class (i.e., to run in the 10-year-old class, the driver must have already celebrated his or her 10th birthday). Likewise, a driver can compete in a lower Age Group class if his or her birthday falls after Jan. 1 of the current year (i.e., a driver who turned 13 on July 1 can compete as a 12-year-old through the entire calendar year).</p>
2.	<p>INTERMEDIATE: ages 10 to 12; dial-in restricted to 8.900 seconds over the 1/8th mile and 13.92 seconds over the 1/4 mile or slower based on either an e.t. dial-your-own or heads-up basis; breakout rules apply. In qualified events, no competitor can qualify quicker than 8.900 or 13.920. Any competitor running quicker than 8.898 e.t. in the 1/8th mile and 14.050 in the 1/4 mile or at any time during an event will receive one warning unless the Clerk of The Course feels further action would be appropriate. If the same competitor runs quicker than 8.898 e.t. in the eighth mile or 14.050 in the 1/4 mile again at the same event, he or she will be disqualified for the remainder of the event and may face further action deemed appropriate by MSA in MSA's sole and absolute discretion. Any competitor running quicker than 8.800 e.t. in the eighth mile or 13.770 in the 1/4 mile at any time during an event will be immediately disqualified for the remainder of the event and may face further action deemed appropriate by MSA in MSA's sole and absolute discretion. Penalties will be imposed regardless of whether the infraction(s) occur during dial in, qualification or eliminations. Accepted aftermarket engines for Novice, Intermediate, Advanced and Master classes: Metro Racing flathead, McGee Racing flathead, Tecumseh flathead, LPW Racing Products monster racing block, JR Race Car flathead, Pure Power Racing flathead, M-1 Machine racing block, SR71 Racing Block by Soltz Racing, Huddleston Performance Sniper, R&S Machine Terminator, TRS block, and Briggs & Stratton 206 factory-sealed engine (with a red, blue or black slide valve) Chassis must be a purpose built junior dragster as per the images in section 14 and Appendix J</p>
3.	<p>ADVANCED: ages 13 to 15; dial-in restricted to 7.900 seconds over the 1/8th mile and 12.400 seconds over the 1/4 mile or slower based on either an e.t. dial-your-own or heads-up basis; breakout rules apply. In qualified events, no competitor can qualify quicker than 7.900. See also Breakout Rules in Race Procedures. Any competitor running quicker than 7.898 e.t. in the eighth mile or 12.390 over the 1/4 mile will be disqualified from the event. Any competitor running quicker than 7.800 e.t. in the eighth mile or 12.240 over the 1/4 mile at any time during dial in, qualification or eliminations will be disqualified from the event and will be subject to additional disciplinary action in the sole and absolute discretion of MSA. Any OEM engine not exceeding 1600cc. Chassis limited to Lotus 7 type chassis or similar or purpose-built junior dragster as per the images in section 14 and Appendix J</p>
4.	<p>MASTER: Ages 16 to 18; dial-in restricted to 7.250 seconds over the 1/8th mile and 11.400 seconds over the 1/4 mile or slower based on either an e.t. dial-your-own or heads-up basis; breakout rules apply. In qualified events, no competitor can qualify quicker than 7.248 seconds over the 1/8th mile and 11.398 seconds over the 1/4 mile. Any competitor running quicker than 7.150 e.t. in the eighth mile or 11.250 seconds over the 1/4 mile will be disqualified from the event. Any competitor running quicker than 7.150 e.t. in the eighth mile or 11.250 seconds over the 1/4 mile at any time during dial in, qualification or eliminations will be disqualified from the event and will be subject to additional disciplinary action in the sole and absolute discretion of MSA. Any OEM engine not exceeding 2000cc, no restriction on chassis</p>
5.	<p>Burnouts and Peel outs are permitted.</p>

6.	Only True Street Car, Modified Street Category Cars and purpose-built Junior Dragsters are permitted, and the proposed vehicle will be subject to a full scrutineering by a senior licensed Chief Scrutineer or Technical Consultant. Modified Race Category cars are strictly prohibited.
7.	All motors to be naturally aspirated. (No forced induction i.e. turbo charged, super charged or nitrous assisted)
8.	The numbers must have the letter "J" prefixed.
9.	Junior competitors can run heads up with any competitor as long as that car is 11.400 seconds or slower over a standing ¼ mile.
10.	At the discretion of the Clerk of the Course and the Safety Officer, junior competitors can be restricted to solo runs only depending on conditions of the circuit including but not limited to surface, run off area and etc.
11.	<p>Driver and Vehicle Evaluation</p> <p>All junior competitors must be formally evaluated in terms of their driving skill and ability, in the vehicle that has been passed for competitive use by the Chief Scrutineer or Technical Consultant, prior to the issuing of a junior license.</p> <p>The junior driver will be evaluated by any Grade A Drag Racing Clerk of the Course or drag racing driver with more than 5 years proven drag racing experience at a competitive level, approved by the MSA Drag Racing Working Group. Particular emphasis will be placed on the junior competitor's ability to launch the vehicle, perform gear shifts while maintaining full control and brake satisfactorily after the finish line, over a standing ¼ mile.</p>
12.	<p>Driver Evaluation Criteria:</p> <p>A minimum of 2 consecutive "successful ¼ mile passes" are required on the day of evaluation to be deemed competent. A successful ¼ pass is defined as follows:</p> <ul style="list-style-type: none"> - Launch the vehicle from the start line without stalling. - Change / engage every gear over the entire ¼ mile without missing a gear if the vehicle is equipment with a manual transmission. Not applicable if the vehicle is equipped with an automatic transmission - Keep the vehicle in a straight line over the entire ¼ mile. - Demonstrate the ability to release the safety harness and exit the vehicle in 10 seconds or less <p>Bring the vehicle to a complete stop before the end of the runoff area without locking or screeching the brakes.</p>
13.	Failure to execute the requirements in point 15 above will constitute a failure, but the competitor will be afforded two attempts of the above requirements on the day. If the competitor is unable to control the vehicle on the launch, the competitor moves side to side over the ¼ mile, fails to bring the vehicle to a complete stop or any combination as prescribed above, it will be deemed as an automatic failure. The regional working group representative must nominate

14.

14.1. Junior Dragster Front View – Trainee to Intermediate



14.2. Junior Dragster Side View – Trainee to Intermediate



14.3 Junior Dragster Option 2 - Side View – Advanced to Master



14.4 Junior Dragster Chassis – Detail

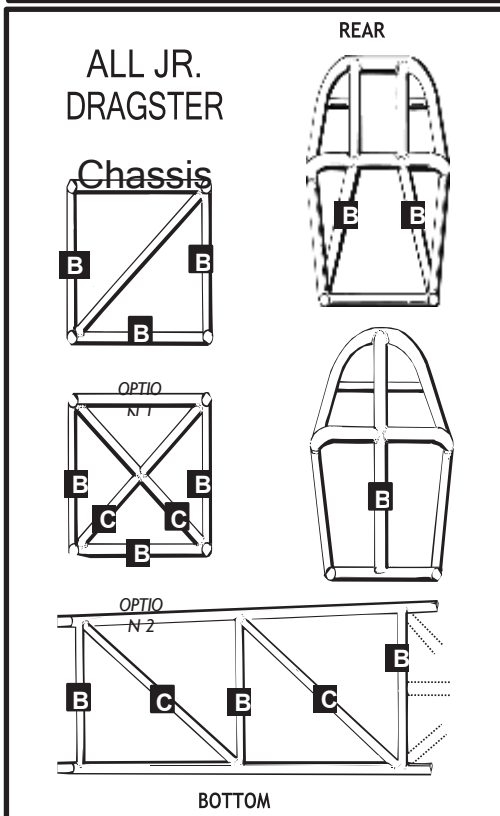
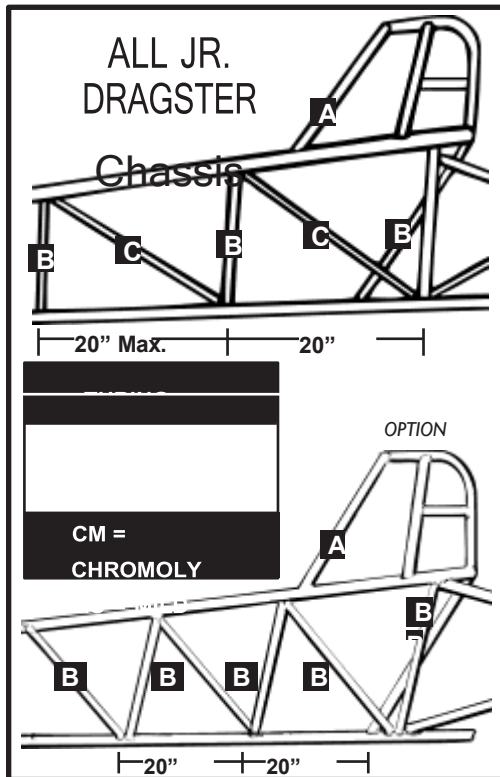

MOTORCYCLES

Regional/Club Motorcycle Drag Racing will consist of two (2) categories as listed below.

SB: Street Bike
PB: Pro Bike

Age limits for classes as per SSR 1 for circuit racing.

GENERAL RULES

1. **BATTERIES**
Must be securely mounted.
 2. **BREATHERS**
OEM or additional oil breather may be fitted.
 3. **CHAIN GUARD**
Full length chain guards are mandatory.
 4. **CLOTHING**
All riders will wear a full-face helmet with visor that meets SABS specification. All riders will wear a full leather race suit, one piece or two-piece, full leather gloves and leather boots which have ankle protection.
 5. **ENGINE**
Nitrous Oxide may not be used in conjunction with any turbocharged or supercharged entrants.
 6. **ENGINE CONTROL UNIT (ECU)**
Motorcycles with aftermarket ECU will be entered into Pro-street class by default.
 7. **FUEL SHUT OFF VALVES**
All motorcycles will have an electrical or mechanical fuel shut off system subject to "TC" approval.
 8. **HANDLEBARS**
Must be OEM or a registered aftermarket substitute.
 9. **IGNITION**
Positive kill switch must be fitted on the handlebars.
 10. **LIGHTS**
For night racing, motorcycles must have functional front and rear lights and must be clearly visible.
 11. **MIRRORS**
Must be removed.
 12. **MUDGUARDS**
Front mudguards must be fitted. Rear mudguards may be removed.
 13. **STEERING STOPS**
Minimum of 5 mm between thumb and tank at full lock.
 14. **THROTTLE**
Must be spring loaded to the closing position. No overrides are permitted.
 15. **TYRES**
Minimum of 1mm tread depth at the commencement of the race meeting.
 16. **WHEEL BASE**
Motorcycles exceeding class wheelbase limitations will be entered into Pro-street or Top bike class by default.
- OTHER
17. **NUMBER BOARDS**
The number board must be placed on the swing arm on both sides of the motorcycle. The letter size must be 40 mm high x 10 mm thick. The number size must be 80 mm high and 20 mm thick black on a white background. Number boards must be a minimum of 200 mm wide x 150 mm high. The number board must display the class designation and competitor's number. No white shoeshine numbers will be allowed at National events. All competitors must carry series sponsors on the number boards, should there be any. If series sponsors are not displayed on the number board the competitor will not be disqualified.
 18. **TECHNICAL INSPECTION**
All motorcycles entered must pass scrutineering and riders must comply with and pass an MSA race gear safety inspection.
THE USE OF NITROMETHANE IS STRICTLY PROHIBITED

STREET / SUPERBIKE

Whatever is not specifically allowed is disallowed.

Minimum Age: 16 years

Handicap and Heads-up racing Bracket Racing only

Normally Aspirated Only!

DIAL – IN

All competitors will enter a dial-in time within 1% of their best qualifying time. If a time is not entered the rider will be disqualified. The maximum dial-in time will be 13.50 seconds. Rider must qualify in both lanes.

Category designation "SB" followed by competitor's race number.

ARTICLE	
1	BRAKES OEM only. Pads and hoses may be replaced.
2	CHAIN GUARD Full length is mandatory.
3	CLUTCH OEM only. Plates and springs may be replaced.
4	ECU OEM ECU Flashing is allowed to optimize settings. Motorcycles with aftermarket ECU/ECMs will be entered into Pro Bike class by default.
5	ELECTRICAL OEM starters and complete charging system must be in place and functional and for night racing, motorcycles must have OEM headlight and taillight connected and functional during the event. OEM wiring harness to be used.
6	ENGINE Internal modifications only.
7	EXHAUST May be modified or replaced.
8	EXTERNAL GEAR RATIOS/GEARING No restrictions to sprockets and chain.
9	FAIRINGS OEM only. Fairings may not be altered or removed. Mirrors and indicators may be removed. Passenger seat pad may be removed and replaced with OEM cover. Fairings must be mounted in original mounting points.
10	FRAME No modification. Must have VIN plate. Rear number plate holder may be removed.
11	FUEL Must comply with MSA GCRs. Any commercially available 93 & 95 octane pump fuel are allowed (Shell, Sasol, Engen, Total), 97 octane VP Racing Fuels (MR9 and MR12 and M5), commercially available ethanol and methanol. THE USE OF NITROMETHANE IS STRICTLY PROHIBITED
12	FUEL TANK No modification. May be filled with Explosive Foam.
13	GEARBOX OEM only. No modifications. Undercutting of gears is allowed. No OTHER modification allowed.
14	GEARSHIFT SYSTEM May be modified for race pattern type gear change. Quick shifters allowed.
15	GROUND CLEARANCE Minimum of 50 mm with the rider seated on the motorcycle, feet on the foot pegs and a minimum of 0.7 bar pressure in each tyre.

- 16 **IGNITION SYSTEM**
No modifications. Must have OEM ignition with OEM ECU's and standard wiring harness. The use of "Power Commander" and "Wide Band" is allowed. No launch control or stutter boxes allowed, however, if OEM, it will be allowed (i.e., new Yamaha R1 and BMW S1000RR) If OEM wiring harness or ECU/ECM is not used motorcycle will be classified as Pro-street
- 17 **INDUCTION**
Internal modification to the throttle bodies is allowed. No aftermarket turbo or nitrous system allowed. Air filter may be replaced. Air box and intake pipes to remain as per the standard OEM motorcycle.
- 18 **REARSETS AND PEDALS**
May be modified or replaced. Passenger foot pegs and mounts may be removed.
- 19 **SUSPENSION**
May be modified. Weights and or strapping is allowed. Linkage may be modified or replaced. Solid struts not allowed. Aftermarket rear shocks allowed, e.g., Ohlin's.
- 20 **SWING ARM**
Motorcycles manufactured before 1990 may use an OEM swing arm from another model of the same manufacturer. Swing arms must be OEM and remain original specification for the make and model and year of motorcycles concerned.
- 21 **TYRES**
Only DOT approved road tyres allowed. No Slicks.
- 22 **WATER PUMPS:** External water pumps not allowed.
- 23 **WHEELS**
OEM only. Polishing and painting is permitted. Lightening or skimming of wheels is not allowed. Aftermarket allowed (manufacturer must be SABS/TUV/ISO approved).
- 24 **WHEELBASE**
Wheelbase must be OEM as per make and model of the motorcycle concerned. **Motorcycles exceeding class wheelbase limitations will be entered into Pro Bike class by default.**

PRO BIKES

Whatever is not specifically allowed is disallowed.

Minimum Age: 16 years

Handicap and Heads-up racing

Category designation "PS" followed by competitor's race number.

ARTICLE	
1	BRAKES OEM or better. Pads and hoses may be replaced. Subject to "TC" approval. Rear brake may be removed. 1 brake disc/rotor/caliper may be removed per wheel.
2	CATCH PAN (OPTIONAL) Must be equipped with a ballistic oil blanket or catch pan. The blanket or pan must cover the lower section of the engine. The catch pan must be able to hold all the oil from the engine.
3	CHAIN GUARD Full length is mandatory.
4	CLUTCH May be modified or replaced.
5	ELECTRICAL May be modified or replaced. Charging system must operate and may be assisted with external charging system. Engine must start with own OEM starter. Battery may be moved or replaced. For night racing, motorcycles must have operational front and rear lights with a minimum diameter of 40 mm. Front light to be white in colour, rear light to be red in colour and must clearly visible. OEM lights may be removed or replaced. Motorcycle must have hand strapped kill switch, maximum length of strap to be 500 mm. Use of control devices to prevent front wheel lift or launch control or 2-step system or stutter boxes are not allowed.
6	ENGINE Internal modifications only. Low profile oil sump may be utilized. Bore and Stroke are allowed to be 1 (one) oversize ONLY. Engine – current SSR refers to only 1 oversize allowed – does not specify inch/mm or maximum cc displacement. Recommend 3mm oversize for piston and + 7mm for stroke. Low profile oil sump may be utilized.
7	EXHAUST May be modified or replaced.
8	EXTERNAL GEAR RATIOS/GEARING No restrictions to sprockets and chain.
9	FAIRINGS May be modified or replaced. Seat and tail section may be modified or replaced and must be extended to cover the rear wheel. Original profile of the motorcycle to be retained.
10	FRAME OEM only. Modifications for strengthening the frame allowed. Accessory brackets may be removed or replaced. Frames may be polished. All modifications subject to "TC" approval.
11	FUEL Any commercially available 93 & 95 octane pump fuel are allowed (Shell, Sasol, Engen, Total), 97 octane VP Racing Fuels (MR9 and MR12 and M5), commercially available ethanol and methanol. THE USE OF NITROMETHANE IS STRICTLY PROHIBITED
12	FUEL TANK May be modified or replaced. Must retain original shape. Sloping at the rear of the tank is allowed.
13	GEARBOX May be modified or replaced. No automatic transmissions allowed. Air or electric shifters allowed.
14	GROUND CLEARANCE Minimum of 50 mm with the rider seated on the motorcycle, feet on the foot pegs and a minimum of 0.7 bar pressure in each tyre
15	IGNITION SYSTEM May be modified or replaced.
16	INDUCTION Turbo or supercharger or nitrous oxide system allowed.

- 17 **NITROUS OXIDE MOTORCYCLES**
Nitrous bottles to be fitted to nitrous motorcycles only and must be securely mounted within the frame rails and mechanically fastened. Hose clamps prohibited.
- 18 **REARSETS AND PEDALS**
May be modified or replaced. Passenger foot pegs and mounts may be removed.
- 19 **SUSPENSION**
Front forks may be modified. Rear suspension may be modified or replaced. Swingarm may be modified or replaced. Original mounting points must be used and may be enlarged. Solid struts or wheelie bars are not allowed. Ballast may be added.
- 20 **TURBO OR SUPERCHARGE MOTORCYCLES**
Turbo or Supercharged motorcycles may not have any nitrous oxide fitted to the motorcycle. Turbocharged or Supercharged entrants are prohibited from using nitrous as a cooling source.
- 21 **TYRES**
Front tyre must be DOT approved road tyre. Rear tyre must be DOT approved road tyre or maximum 7 inch wide slick.
- 22 **WATER INJECTION**
Competitors using water injection may only pressurize the water tank with air. The water tank must be mounted in a manner as to allow easy access for the "TC" to inspect its contents. No other substance other than water is allowed to be in the tank.
- 23 **WHEELS**
OEM and aftermarket allowed (manufacturer must be SABS/TUV/ISO approved). Polishing and painting is permitted. Lightening or skimming of wheels is not allowed.
- 24 **WHEELBASE**
Maximum 1803mm/71inches mm. Measured from centre front axle to centre rear axle.

QUALIFYING, PAIRINGS AND LADDERS

1. During the qualifying session, each competitor is required to complete at least one run in order to be paired for main eliminations. Qualifying is purely to gauge what times a vehicle is capable of running in order to set a dial-in time for main racing. Red Lighting does not disqualify a competitor from main racing. Failing to complete a run during this session does. Please note that practice runs do not count.
2. Race Control manually monitors each run during qualifying. The best time is taken and deducted from the class record. Ranking is then done sequentially, starting from the competitor who ran closest to the class record. With the exception of the SBS class who run on Pro-Ladders, all other classes are then paired on Sportsman's Ladders.
3. As previously stated in DR 6, [6.1], Bye Runs are compulsory and are awarded in progressive order, e.g., if a field produces three Bye Runs, the Top Qualifier will receive the first, the No. 2, the second and the No. 3, the third. On an uneven field, the Top Qualifier always receives a Bye Run. The breakout rule does not apply during a Bye Run, but Red Lighting does.
4. In order to set up a Sportsman's Ladder so that the Number 1 and 2 qualifiers meet in the final, a proposed conclusion needs to be arrived at. Assuming that the slowest qualifiers will fall away, the following example shows how to set up a 10 car/bike field.

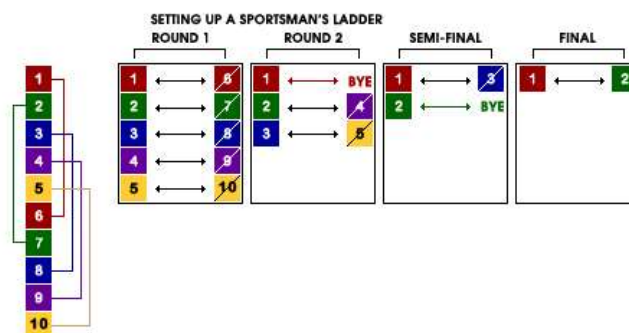

Working backwards from the final round, the ladder will appear as follows:

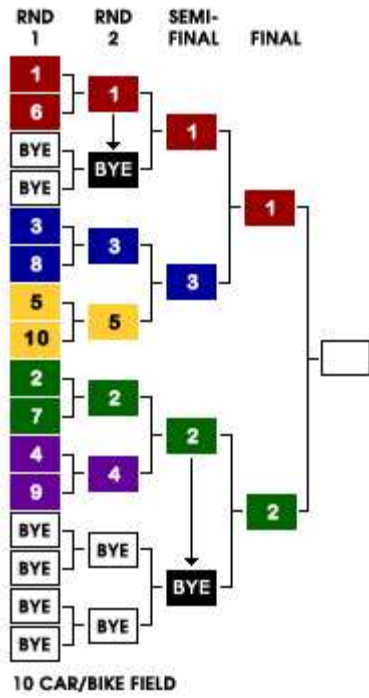

- 1 There are only four instances where the top qualifiers will not meet in the final. It is unavoidable and that occurs on Fields, 9, 18, 19 and 21.
- 2 In order to set up a Pro-Ladder, the same principle is applied, however, fastest is paired against slowest as per the following example.

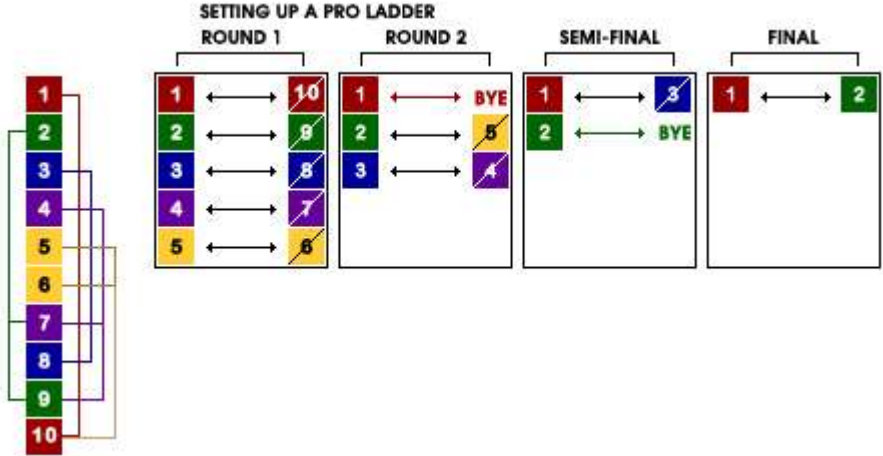

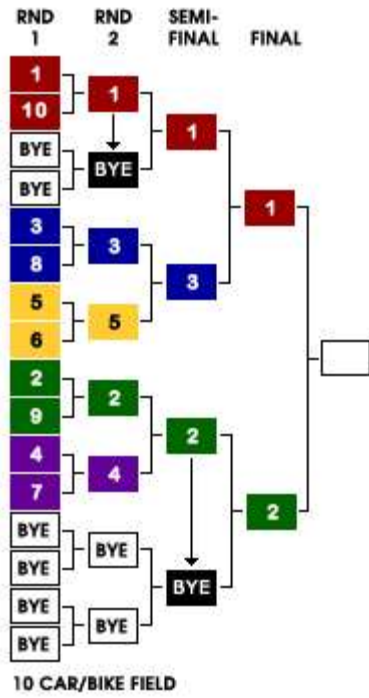

NOTE: This system is applied regardless of whether the competition has been set up for handicap or heads up racing. Dial-in times do not affect the ladders in any way.