



2026

**MSA NATIONAL STANDING
SUPPLEMENTARY REGULATIONS**

**NATIONAL ROTAX KARTING
CHAMPIONSHIP**



VERSION 2

9 APRIL 2026

WWW.MOTORSPORT.CO.ZA

REVIEW AND AMENDMENTS

Amendments and updates to the rules will be recorded in the Amendment Record, detailing the amendments, date applicable and a short summary of amendments.

AMENDMENT RECORD

<i>Modified SSR / ART</i>	<i>Date applicable</i>	<i>Date of Publication</i>	<i>Clarifications</i>
ART 4	2026.04.09	2026.04.09	FIXED NUMBERING

1. TABLE OF CONTENTS	
2. GENERAL	3
3. ADMINISTRATION	4
4. CHAMPIONSHIP OUTLINE	4
4.1. SA ROTAX MAX CHALLENGE NATIONAL CHAMPIONSHIP	4
4.2. ROTAX AFRICAN OPEN	5
5. CALENDAR	6
5.1. CIRCUIT CLOSURE	6
6. REGULATIONS	7
7. CATEGORIES, LICENCE, AGE AND WEIGHT	7
8. ELIGIBLE DRIVERS	9
9. QUALIFICATION FOR RMC GF	10
10. OTHER RULES	11
11. GENERAL UNDERTAKINGS	12
12. GENERAL CONDITIONS	12
13. RACING NUMBERS AND NAME OF THE DRIVER	12
14. OFFICIALS	13
15. ELIGIBLE KARTS AND EQUIPMENT	13
15.1. CHASSIS	13
15.2. ENGINE AND CLAIM SYSTEM	14
15.3. BRAKES	15
15.4. SAFETY EQUIPMENT	15
15.5. TYRES	15
15.6. FUEL	15
15.7. TRANSPONDER	16
15.8. ONBOARD CAMERA	16

16. SPORTING CHECKS AND SCRUTINEERING	17
17. BRIEFINGS	18
18. PARC FERME	18
19. SERVICING PARK	18
20. PRE-GRID	18
21. RACE EVENT	18
NON -QUALIFYING PRACTICE:	19
QUALIFYING PRACTICE	19
STARTING GRID	19
22. STARTING PROCEDURE	20
STOPPING / RESTARTING A RACE	21
RESUMING A RACE WITH “SLOW PROCESS”	23
RESTART PROCEDURE	23
23. DEAD HEATS BETWEEN DRIVERS	24
24. SCALE / WEIGHING PROCEDURE	24
25. FRONT FAIRING	25
26. EVENTS COUNTING TOWARDS THE SARMC AND POINT SCORING	26
27. COMBINING OF CLASSES	27
28. PODIUM CEREMONY	27
29. NOTIFICATIONS BY THE COC OR THE STEWARDS DECISIONS TO DRIVERS / ENTRANTS	27
30. HOW THE ROTAX GLOBAL APP WORKS	27
31. COMMUNICATION FLOW	28
32. INSTRUCTIONS AND COMMUNICATIONS TO COMPETITORS/ENTRANTS	28
33. FINES	28
34. PROTEST AND APPEALS	28
35. PADDOCK RULES	29
36. FIRE EXTINGUISHERS	29
37. CODE OF CONDUCT FOR DRIVERS	29
38. GENERAL SAFETY	30
39. PENALTY CATALOGUE	31
40. LICENSE PENALTY SYSTEM (LPS)	37
41. FLAGS	38

2. GENERAL

BRP-ROTAX GmbH & Co KG, Rotaxstr. 1, 4623 Gunskirchen, Austria and its authorised distributors / partners organize the ROTAX MAX Challenge Grand Finals (RMCGF), International ROTAX MAX Challenges (IRMC) and National ROTAX MAX Challenges (RMC).

ROTAX MAX Challenge

Describes the concept of the ROTAX MAX Challenge program and specifying the regulations for the national RMC's in various countries which are the basis for the qualification for the RMCGF.

All the parties concerned (FIA, CIK-FIA, ASN, organisers, entrants and circuits) undertake to apply and observe the rules governing the race events.

Any International RMC event shall be run in accordance with the RMC Series Sporting Regulations, the RMC Technical Regulations and the International Sporting Code

(«the FIA-Karting-International Sporting Code») and its Appendices, with the Karting Technical Regulations («the FIA Karting Technical Regulations») and with any international regulations including these, with the General Prescriptions applicable to FIA Karting International events («the FIA-CIK General Prescriptions»), as well as with any supplementary regulations drawn up by the ASN concerned.

Any changes or exemptions to the RMC Sporting regulations and RMC Technical regulations require the written approval of ROTAX following the agreement of the ASN presenting the series and or FIA Karting.

ANYTHING WHICH IS NOT EXPRESSLY ALLOWED IS FORBIDDEN

3. ADMINISTRATION

- a) South African Rotax Max Challenge (SARMC) Karting is administered under the provisions of the General Competition Rules of Motorsport SA (GCR's) and these SARMC Sporting Regulations (SARMC SSR's) the Global Rotax Technical Regulations, the SARMC Supplementary Technical Regulations and the Supplementary Regulations (SR's) published for each karting event.
- b) Where there is a contradiction between the GCR's and these SARMC SSR's the latter shall take precedence.
- c) Neither the MSA Karting SSR's nor the SSR's for circuit racing apply to SARMC events.
- d) Individual event SR's may not conflict with these SARMC SSR's
- e) Regional and club regulations may not be in conflict with these SARMC SSR's unless written authorization is obtained from the promoter. Where individual club or regional regulations are silent on this, and in the event of a dispute these SARMC SSR's will take precedence.

ANYTHING WHICH IS NOT EXPRESSLY ALLOWED IS FORBIDDEN.

4. CHAMPIONSHIP OUTLINE

4.1. SA ROTAX MAX CHALLENGE NATIONAL CHAMPIONSHIP

RACE CLASSES	STATUS	PRIZES
Bambino Minimum age: see 7.2 Minimum weight 74 Kg	SA National Championship	World Final Replica Suit
Micro Max Minimum age: see 7.2 Minimum weight 105 Kg	SA National Championship	World Final Invitation
Mini Max Minimum age: see 7.2 Minimum weight 115 Kg	SA National Championship	World Final Invitation
Junior Max Minimum age: see 7.2 Minimum weight 145 Kg	SA National Championship	World Final Invitation
Senior Max Minimum age: see 7.2 Minimum weight 162 Kg	SA National Championship	World Final Invitation

ROTAX DD2 Minimum age: see 7.2 Minimum weight 175 Kg	SA National Championship	World Final Invitation
DD2 Masters Minimum age: see 7.2 Minimum weight 180 Kg	SA National Championship	World Final Invitation
E10 BAMBINI/MINI	Club Class	TBA

Minimum average of 6 starters per class to declare a National Champion for 2026.

NB! To receive any prize including an invitation to the RMCGF it is mandatory to participate in the National Final.

4.2. ROTAX AFRICAN OPEN

RACE CLASSES	STATUS	PRIZES
Bambino Minimum age: see 7.2 Minimum weight 74 Kg	Africa Open	World Final Replica Suit
Micro Max Minimum age: see 7.2 Minimum weight 105 Kg	Africa Open	World Final Replica Suit or RMCGF Invitation if one becomes available
Mini Max Minimum age: see 7.2 Minimum weight 115 Kg	Africa Open	World Final Invitation
Junior Max Minimum age: see 7.2 Minimum weight 145 Kg	Africa Open	World Final Invitation
Senior Max Minimum age: see 7.2 Minimum weight 162 Kg	Africa Open	World Final Invitation
ROTAX DD2 Minimum age: see 7.2 Minimum weight 175 Kg	Africa Open	World Final Invitation
DD2 Masters Minimum age: see 7.2 Minimum weight 180 Kg	Africa Open	World Final Replica Suit or RMCGF Invitation if one becomes available.
E10 BAMBINI/MINI	Club Class	TBA

ROTAX AFRICAN OPEN

04.07.2026 Standalone event at Zwartkops, Final race of the day determines African Open winner.

- * If a driver wins the African Open and the National Championship, he/she will keep the ticket for the African Open and the runner up of the National Championship will receive the National ticket. In order to be eligible to qualify for a RMCGF ticket a driver must have held a licence for the territory in question from the first to the last round of the any National RMC. A driver cannot change his/her licence to become eligible to win a RMCGF ticket in another territory after the first round has been completed. Only African domiciled and licenced competitors are eligible to win tickets to the Grand Final.

5. CALENDAR

NATIONAL EVENTS

- 28.03.2026 Killarney 3 races
- 26.04.2026 iDube 3 races
- 14.06.2026 FK 3 races
- 29.08.2026 Zwartkops 4 races

NORTHERN REGIONS

- 28.02.2026 ZIKR
- 16.05.2026 FK
- 04.07.2026 ZIKR
- 01.08.2026 VKC

WESTERN PROVINCE

- 18.04.2026 Killarney
- 16.05.2026 Killarney
- 06.06.2026 Killarney
- 08.08.2026 Killarney

EASTERN CAPE

- 18.04.2026 Celso Scribante Circuit
- 23.05.2026 Celso Scribante Circuit
- 20.06.2026 Celso Scribante Circuit
- 25.07.2026 Celso Scribante Circuit

BORDER

- 21.03.2026 East London Kart Circuit
- 18.04.2026 East London Kart Circuit
- 16.05.2026 East London Kart Circuit
- 20.06.2026 East London Kart Circuit

KWA-ZULU NATAL

- 01.03.2026 Idube
- 12.04.2026 Idube
- 17.05.2026 Idube
- 25.07.2026 Idube

INFORMATION - THE CHAMPIONSHIP CO-ORDINATOR

Jennifer Verheul

Tel: +27 82 294 7485

Email: jennifer@kart.co.za

www.kart.co.za

5.1. CIRCUIT CLOSURE

Circuits will be closed to all national competitors, as well as the equipment to be used in the National Championship event from 17:00 on the Sunday, a minimum of 10 days prior to a National Championship event until 09:00 on the Thursday (or Friday where the final is on Sunday) of the event. Competitors caught transgressing this regulation will start each race from the back of the grid.

NB! Competitors participating in race events at the same circuit within one week prior to any SARMC National event will not be permitted to practice before official practice on Friday (or Saturday where the final is on Sunday). The circuit remains closed for these competitors from the end of the event until the start of official practice.

6. REGULATIONS

The Event shall be run in accordance with:

- the FIA Karting International Sporting Code and its appendices
- the FIA Karting official Bulletins
- the FIA Karting Technical Regulations
- the General Prescriptions applicable to FIA Karting International Events (Chapter 4.1 of the International Karting Regulations)
- the Global Rotax MAX Challenge Technical Regulations 2026
- the Global Rotax MAX Challenge Sporting Regulations 2026
- The General Competition Regulations (GCR's) of Motorsport South Africa (MSA)
- these South African Rotax MAX Challenge Sporting Regulations 2026
- the SARMC Supplementary Technical Regulations 2026 as approved by Rotax
- the Technical and Supplementary Sporting Regulations for Bambino
- the official bulletins

All drivers, entrants and officials participating in the SARMC 2026 undertake, on behalf of themselves, their employees and agents, to observe all these regulations.

Headings in this document are for ease of reference only and do not form part of these Sporting Regulations. Rotax reserves the right to amend this regulation.

7. CATEGORIES, LICENCE, AGE AND WEIGHT

CATEGORIES

The categories available for the SARMC 2026 are the following:

- Bambino *
- 125 Micro MAX
- 125 Mini MAX
- 125 Junior MAX
- 125 Senior MAX
- 125 MAX DD2
- 125 MAX DD2 Masters
- **E10 BAMBINI (Club Class)**
- **E10 MINI (Club Class)**

***BAMBINO Class utilises a Top Kart / Comer kart and as it is not a Rotax product, so the details of this class can be found in SARMC Bambino Supplementary Sporting and Technical Regulations 2026.**

7.1. LICENCES

All licences hereafter have to be issued by MSA which is a member of the FIA.

For SARMC National Championship events a national licence or international licence is required. For SARMC Regional Championship events a Regional, National licence or International licence grade is required.

For IRMC events an international licence grade G, E or F (depending on category) and an international entrant licence is required. International licences will be issued as per the 2026 FIA Karting Sporting Regulations.

7.1.1. COMPETITORS – ENTRANT REQUIREMENTS

The following regulations are supplementary to the General Competition Rules of MSA.

The provisions of GCR 22 notwithstanding, in karting should a parent or court-appointed legal guardian not be in a position to act as the entrant for his or her minor child, he or she may nominate another parent/legal guardian whose minor child is taking part in the same event/s or, alternatively, an adult competitor taking part in the same event, to act as his/her entrant by proxy. To be valid, any such proxy nomination must be submitted, in writing and signed by the parent/legal guardian appointing the proxy, to the Secretary of the meeting for the relevant event/s prior to the commencement of competition.

An adult competitor may appoint another adult competitor competing in the same event to act as his/her entrant. Subject to what is set out below in order for that appointment to be valid, that appointment must be submitted in writing recording the reasons for the appointment and signed by the adult competitor appointing another adult competitor to act on behalf of his/her behalf to the Secretary of the meeting for the relevant event prior to the commencement of the event.

For the purposes of this Regulation, an adult competitor excludes any person/s or body deemed to be a competitor (as envisaged in GCR 19) as a consequence of being an entrant in terms of GCR 22.

The Stewards and/or the Clerk of the Course shall be entitled to investigate the reasons why a parent/legal guardian and/or an adult competitor is not in a position to act either for himself/herself or for his/her minor child as an entrant. The Stewards and/or the Clerk of the Course shall in their sole and absolute discretion be entitled to accept and/or reject the appointment of either the third party nominated to act for a minor child or an adult competitor nominated to act for another adult competitor.

It is the entrant's responsibility to ensure that all persons concerned by his entry observe all the provisions of the code, the technical regulations, and the sporting regulations.

The person having charge of an entered kart during any part of an event is responsible jointly with the entrant and/or separately for ensuring that the provisions are observed.

Entrants must ensure that their karts comply with the conditions of conformity and safety throughout the event.

The presentation of a kart for scrutineering will be deemed an implicit statement of conformity.

Entrants, drivers, assistants, and guests must always wear the appropriate identification credentials which have been provided to them.

7.2. AGE LIMITS FOR RACING IN SOUTH AFRICA

Bambino

Age limits: the driver must have at least his/her 5th birthday during the year of the event and must have his/her 10th birthday after the year of the event

125 Micro MAX

Age limits: the driver must have his/her **7th** birthday during the year of the event and must have his/her **12th** birthday after the year of the event.

125 Mini MAX

Age limits: the driver must have his/her **9th** birthday during the year of the event and must have his/her **14th** birthday after the year of the event.

125 Junior MAX

Age limits: the driver must have his/her **12th*** birthday during the year of the event and must have his/her **15th**** birthday after the year of the event.

** To be eligible to race Junior Max before the year of the 12th birthday, the driver must be at least 11 years old (had his 11th birthday), weigh more than 40 kg or be taller than 1.5 meters. In this case it is understood that the driver is not eligible to compete at the Rotax Grand Finals.*

****** A driver (that is) 15 years old during the year of the event can participate in Junior MAX category at the RMCGF only if he/she is placed on the official FIA list for special licence cases to be able to hold a valid International G Karting Licence, according to Article 3.4.1 of the FIA INTERNATIONAL DRIVERS' LICENCES FOR KARTING DRIVERS & CODE OF DRIVING CONDUCT. Female competitors over the age of 15 may continue competing in Junior Max. While a 15-year-old or an older female driver can participate and win the National Championships in the Junior MAX category, they cannot compete at the RMCGF unless they possess the aforementioned licence.

125 Senior MAX

Minimum age: the driver must have his/her **14th birthday** during the year of the event.

125 MAX DD2

Minimum age: the driver must have his/her **15th** birthday during the year of the event.

125 MAX DD2 Masters

Minimum age: the driver must have his/her **32nd** birthday during the year of the event.

E10 BAMBINI

Age limits: the driver must have his/her **8th** birthday during the year of the event and must have his/her **12th** birthday after the year of the event.

E10 MINI

Age limits: the driver must have his/her **10th** birthday during the year of the event and must have his/her **14th** birthday after the year of the event.

7.3. SUMMARY AGE LIMITS FOR THE RMCGF AND INTERNATIONAL RMC

Each participant of the Rotax Max Challenge 2026 represents the nation whose ASN has issued him the licence regardless to which nationality he belongs or in which country he has qualified.

All drivers fulfilling these age limits and type of licences are eligible to qualify for the RMCGF 2026.

	MICRO/E10 BAMBINI	MINI/E10 MINI	JUNIOR	SENIOR	DD2	DD2 MAS- TERS
Age limit	8-11	10-13	12-14 *(15)	15+ *(14)	15+	32+
Age groups	2018-2015	2016-2013	2014-2012	from 2011 *(2012)	from 2011	from 1994

***... if the driver holds a Karting Licence, according to Article 3.4.1 (and is placed on the official ~~CK~~FIA list for special license case holders) and 3.4.2 of the FIA international driver's licences for karting drivers & code of driving conduct.**

7.4. MINIMUM WEIGHTS FOR SARMC

The minimum weight for the kart, including driver and all required safety equipment (helmet, overall, gloves, etc.) must always be:

Minimum Weights (KG)	MICRO	MINI	JUNIOR	SENIOR	DD2	DD2 MASTERS	E10 BAM	E10 MINI
	105	115	145	162	175	180	105	120

8. ELIGIBLE DRIVERS

RMCGF seats will be awarded by a qualification matrix executed by ROTAX. Responsible distributors may split up the granted seats among their territories. The number of seats per territory can change yearly.

ROTAX reserves the right to offer wild cards and driver packages to drivers according to criteria as it deems fit.

ROTAX also reserves the right not to accept an entry, without having to provide any justification. As per MSA GCR 99 (i) and 100.

ROTAX reserves the right to grant additional drivers from different classes to different countries under certain conditions to participate at the RMCGF.

The RMCGF 2026 is an international restricted event by invitations controlled by ROTAX (according to the FIA Karting International Sporting Code).

Expenses for the supplied karts, engines, tyres, petrol and entry fee for qualified drivers of the RMCGF 2026 is covered by ROTAX and its distributors. (Except E20 and E10 class)

Drivers can qualify via International or Nationals event providing the ROTAX MAX CHALLENGE Global sporting regulations 2026 and "ROTAX MAX CHALLENGE Global Technical regulations 2026 are followed in the RMC classes. With prior pre agreement ROTAX selected distributors can utilise the seat allocation to nominate loyal ROTAX customers to participate at the RMCGF 2026.

ROTAX reserves the rights to manage participation for Project E20 and E10 events as it sees fit.

9. QUALIFICATION FOR RMCGF

125 Micro Max, 125 Mini MAX, 125 Junior Max, 125 Senior MAX/Masters and 125 DD2 MAX/Masters class: The overall winner of each national RMC class with authorisation in writing from ROTAX may qualify.

E20 and E10 RMCGF tickets will be awarded to the Champions of E20 events or Championships as defined in the event specific regulations. The prize is non-transferable.

Additional drivers can qualify via international or National RMC.

The number of qualifying drivers must be defined in the sporting regulation of the respective race series.

DD2 MAX Masters: The overall winner of each national RMC, DD2 MAX Masters and/or Senior MAX-Masters class and/or the overall best placed master's driver (fulfilling the age limits for a Master's category following Rotax Global Sporting regulations 2026) of a national RMC in MAX or DD2 class with authorisation in writing from ROTAX may qualify.

At any time ROTAX reserves the right to offer wild cards or loyal ROTAX customer driver packages to drivers of all classes according to criteria as it deems fit.

In order to be eligible to qualify for a RMCGF ticket a driver must have held a licence for the territory in question from the first to the last round of the any National RMC.

A driver cannot change his/her licence to become eligible to win a RMCGFs ticket in another territory after the first round has been completed.

If a driver is not respecting the rules, under any doubt ROTAX reserves the right to refuse entry to the RMCGF.

A distributor may nominate a second placed driver from an RMC to the waiting list for RMCGF. If under any circumstances a qualified driver doesn't arrive at the RMCGF till the official registration is completed, Rotax reserves the rights to add a replacement driver from the top of the waiting list to take part at the event.

This rule applies until the start of the official non-qualifying practice at the RMCGFs.

ROTAX reserves the rights to manage qualification for Project E20 events as it sees fit.

If under any circumstances a qualified driver doesn't arrive at the RMCGF till the official registration is completed, Rotax reserves the rights to add a replacement driver from the top of the waiting list to take part at the event.

The driver/entrant must not be involved in ongoing court proceedings (ongoing sporting or civil lawsuits somehow related to the RMCGF 2026 which prohibits a result) after the registration deadline, neither as a prosecutor nor as a defendant, otherwise the next placed driver is allowed to register in his/her place.

10. OTHER RULES

A driver can only win one RMCGF ticket per year, this will be the first ticket the driver wins in the racing season defined by the date of the final.

If a driver competes in a higher ranked category the driver is eligible to qualify for the RMCGF in the higher ranked category. If this situation arises the lower ranked category ticket is passed down to the next eligible driver in the series / event it was awarded at.

Category Ranking is:

1. E20 Senior/E20 Master (depending on the age of the driver)
2. E20 Junior
3. DD2 MAX or DD2 MAX Master (depending on the age of the driver)
4. Senior Max or Senior Max Master (depending on the age of the driver)
5. Junior MAX
6. Mini MAX
7. Micro MAX

At any double qualification ROTAX reserves the right to decide which race series counts for the qualification to avoid any strategic behaviour of competitors.

Note*

It is strictly forbidden to offer RMCGFs tickets for sale, the RMCGFs tickets are offered as rewards for ROTAX drivers around the world.

*not applicable to the Project E20 and E10 category

Project E20

If a driver qualifies to race at the RMCGFs in one of the categories listed above and the Project E20 (no matter the date that he will get this ticket), the driver must notify ROTAX via email immediately after acquiring the second ticket which RMCGFs category, they wish to participate in.

Once this email is received and accepted in return by ROTAX the decision is final and cannot be reversed. (Email: Sara.Jernejc@brp.com)

The Qualification priority for E20 RMCGF 2026 tickers is as follows:

- Championship or Event winner
- Voucher winners.
- Drivers that drove, at least, one event in 2026 season in E20
- Open entry

All the remaining seats will be available on open registration following the requirements of these regulations.

ROTAX reserves the rights to manage E10 RMCGF qualification

11. GENERAL UNDERTAKINGS

Any special national / Continental (Zone) / International regulations must be submitted to the ASN / FIA Karting with the original application for inclusion of the RMC 2026 on the National / Continental (Zone) / International calendar. Only with the approval of the ASN / FIA Karting such special regulations can come into force.

The supplementary regulations of the RMC 2026 consist in standard regulations drafted in English and possibly translated into other languages.

The right to associate the name of a company, organisation or commercial make to the RMC 2026 is exclusively reserved to ROTAX. Unless there is a previous written agreement from ROTAX, no organiser or group of organisers may indicate or make believe that the said event is sponsored or financially helped either directly or indirectly by a commercial firm or organisation.

Only ROTAX is entitled to grant waivers to these sporting regulations, following the agreement of the ASN presenting the series and or the FIA Karting.

ANYTHING WHICH IS NOT STATED TO BE ALLOWED IS FORBIDDEN.

12. GENERAL CONDITIONS

It is the entrant's responsibility to ensure that all persons concerned by his entry observe all the provisions of the code, the technical regulations and the sporting regulations. If an entrant is unable to be present in person at the event he/she must nominate his representative in writing.

The person having charge of an entered kart during any part of an event is responsible jointly with the entrant and / or separately for ensuring that the provisions are observed.

Entrants must ensure that their karts comply with the conditions of conformity and safety throughout the Event.

The presentation of a kart for scrutineering will be deemed an implicit statement of conformity.

Entrants, drivers, assistants and guests must always wear the appropriate identification credentials which have been provided to them.

13. RACING NUMBERS AND NAME OF THE DRIVER

Racing numbers shall comply with provisions of the FIA Karting Technical Regulations or local ASN for National events.

The name of the Driver and nationality shall appear on each side of the lateral bodywork and be clearly legible, in accordance with Article 3.7 of the FIA Technical Regulations. At the RMCGF, it must also appear in large letters on the drivers race overall, at the top of his back and on each of his legs.

The flag of the Driver's nationality shall be that of the nationality of his licence.

All karts must have visible, at all time during the event, the four starting numbers (one on the back, one on the front, and one on each side of the kart).

Driver will not be allowed to enter the Servicing Park without all the racing numbers present on the kart in a good condition.

Racing numbers for each category are:

- Bambino 1 to 99 Black number yellow backing
- Micro MAX 601 to 699 Black number yellow backing
- Mini MAX 501 to 599 White number blue backing
- Junior MAX 401 to 499 White number green backing

must be from the same “Manufacturer” and “Model”.

15.2. ENGINE AND CLAIM SYSTEM

Engine and its accessories must be used in accordance with the RMC Global Technical Regulations 2026 and the MSA Comer CX52 Technical Regulations 2026

- Engine and cylinder numbers registered to South Africa can be checked here – <https://kart.co.za/tech-check>

Engine buy out - Karting is plagued with claims that you can import special tuned kart engines from exotic countries, rumours of extraordinary amounts of money being spent have been around in motorsport and karting for decades.

The engine claim system gives everyone peace of mind that the playing field is level and accessible.

ENGINE CLAIM PROCESS – APPLICABLE ONLY TO BAMBINO, MICRO, MINI AND JUNIOR MAX

- 15.2.1. By entering the SARMC Series everyone agrees to make their engine available for the claim system. Engines can only be claimed at one of the four SARMC National events and the Rotax African Open event.
- 15.2.2. Any refusal to comply with the claim system will lead to any points scored by the competitor in question in the national series being annulled.
- 15.2.3. No further entries will be accepted in any SARMC class from a competitor refusing to comply with the engine claim system.
- 15.2.4. An irrevocable offer to purchase the winner’s engine must be submitted via www.kart.co.za/engine-claim/ with the proof of payment by a claimant on race day before the start of the first race/heat. A maximum of three claims per class at any event will be accepted. The claims will be drawn from a hat to determine a ranking.
- 15.2.5. The Stewards will notify the claimants at the end of the last race if the winner’s engine has already been claimed. If there are multiple claims for an engine in a class and what the ranking of those claims is.
- 15.2.6. For Rotax engines, the claim price will be based on the current new price as published on www.kartstore.co.za plus (ten) 10%.

For Bambino engines, the claim price will be based on the current new price as published on www.kartstore.co.za plus R 4 000.00. The claimant must pay the price plus R 4 000.00 to the organisers.
- 15.2.7. At the end of the days racing once the 30 (thirty) -minute parc-ferme time period has expired or after any technical strip is concluded the motor will be impounded by the organisers.
 - In the event that the claimed engine is found to be illegal in the post-race technical strip, the second placed competitors engine automatically becomes the “winner’s claimed” engine and so on.
 - If the winner has used two engines on the day the claimant may choose one of the two engines used.
- 15.2.8. A competitor may only claim an engine once per season. Only the driver that claimed the engine will be allowed to use the claimed engine in SARMC events.
- 15.2.9. A competitor may only have his/her engine claimed once per season and may not race the engine claimed again in the same season.
- 15.2.10. If a winner’s engine is claimed and it happens to be someone whose engine has previously been claimed (as in 15.2.9. above) then the second placed competitors engine automatically becomes the “winner’s claimed” engine and so on. Note point 15.2.5. above.

- 15.2.11. If the competitor submitting the successful buyout claim is the winner of the day then the second placed competitors engine automatically becomes the “winner’s claimed” engine and so on. Note point 15.2.5 above.
- 15.2.12. The organisers are only the facilitator in the claim system and cannot be held responsible for the condition or eligibility of the engine and all the risk lies with the claimant. The claimant is advised to be present at every step of the process.
- 15.2.13. Once the claimant has paid to the satisfaction of the Organisers the seller will be issued with a certificate from Ed Murray Racing cc against which a new engine (as per claim) as well as the payment of the (ten) 10% into their nominated bank account will be made.

15.3. BRAKES

The brakes must be homologated by the FIA Karting and as specified in Rotax Global Technical Regulations 2026. In the case of chassis with a wheelbase of less than 950mm (Bambino, Micro and Mini) older karts fitted with original braking systems as approved by Italian Federation or similar are acceptable.

15.4. SAFETY EQUIPMENT

Helmets, gloves, rib protectors, boots, race overalls must all be approved under the FIA Karting Technical Regulations Article 7. MSA approval is also acceptable refer to GCR 239.

15.5. TYRES

Tyres as specified in the SARMC Supplementary Technical Regulations 2026 as approved by Rotax are the only tyres allowed for the SARMC 2026.

15.6. FUEL

Commercial quality petrol from a specified roadside petrol station only, maximum 95 Octane, mixed with XPS CASTOR RACING OIL 2T.

It is incumbent on the competitor to ensure that they purchase the correct fuel and mix it in the correct ratio as specified in the SR’s for the event so that when a pre-race check is conducted on the pre-race grid that the fuel meets the Digatron FT64 reading for the day.

The following test method will apply to all karting events and classes as approved by MSA, Club, Regional and Nationals.

The test instrument will be the Digatron FT64 which must be clearly identified by a serial number or identifying mark and will be the only instrument of the day to be used. Only MSA approved Technical Consultant/s (TC’s) may perform fuel testing.

The only calibration on the instrument of the day will be the reading from the mixed reference sample fuel that is kept by the fuel TC.

A clearly marked reference sample of every mix ratio (fuel: oil) will be kept by the fuel TC or COC.

The difference in reading between the reference sample that is applicable for each class and competitor fuel reading may not be more or less than (two) 2 points, this value may be changed by the Fuel TC of the event before qualifying. Fuel testing can be done at any time during the event.

The temperature difference between samples may not be more than (two) 2 degrees Fahrenheit. If the temperature and dielectric reading is not within limits the Fuel TC may insist that the competitor change to fuel that complies before being allowed to race. The COC or Fuel TC may at any time have competitors fuel replaced with organisers fuel. Refusal to do so will lead to exclusion without the possibility to protest.

The minimum amount of fuel in the tank at any time may not be less than 300ml, the fuel may be de-canted

into a suitable container for the necessary testing to be done.

It is the responsibility of the competitor to always be present when readings of the fuel are done and to check with the fuel TC that the fuel used by competitor is within the set parameters.

15.7. TRANSPONDER

The driver / entrant must have his own transponder, and it is his / her responsibility to ensure that it is charged and functioning at all times whenever he / she will be on the track. Transponders may be rented from the organisers or others, but the responsibility rests with the competitor/entrant to ensure the transponder is ~~have~~ a functioning and fitted from the start of the event i.e., from the start of official practice.

The use of the transponder is mandatory at all times from the first non-qualifying practice session of each ~~driver~~ competitor and until after the Final race of the event. It is the entrant / driver's responsibility to mount the transponder securely in the correct position.

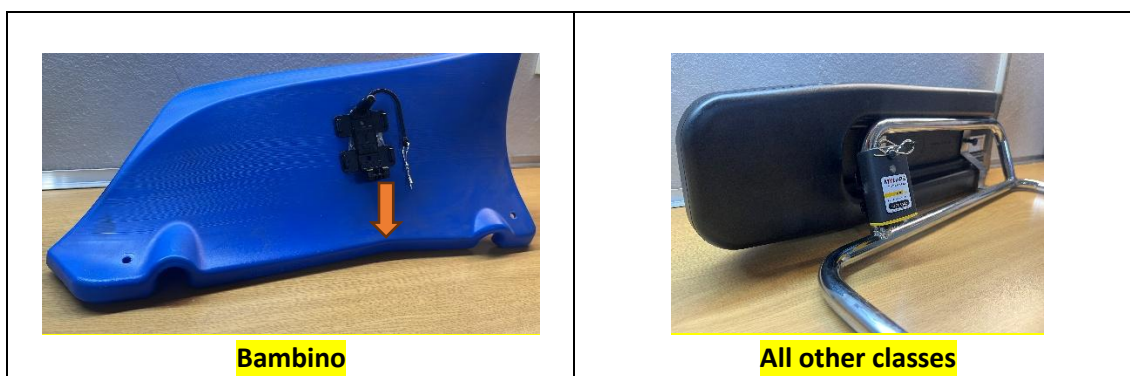

By determination of the Chief Scrutineer, under approval of the Clerk of the Course, the transponder positioning may be changed

15.8. ONBOARD CAMERA

The organiser reserves the right to equip Karts of drivers with an onboard camera system. Selected drivers must mount the onboard camera system in accordance to the series / event Supplementary regulations. The total weight of all components counts to the total weight of the kart. The driver cannot refuse to install the onboard camera on his / her kart.

To assist officials in enforcing fair and sporting driver conduct, the use of onboard camera systems is highly recommended and will become compulsory in the near future. The organisers recommend the use of an Insta360 camera or an equivalent 360° system, or alternatively, front- and rear-facing cameras.

15.8.1. Installation

- Fitting the camera to the radiator is recommended.

15.8.2. Noting/Forwarding Footage

- Competitors may forward footage of an incident they may have witnessed or been involved in.
- The footage must carry a date and time stamp corresponding to the session.
- The footage must be submitted via www.kart.co.za/submit-footage/.
- This footage may not always be viewed by an official during the event due to time constraints and any competitor who considers himself/herself sufficiently aggrieved and requires an issue to be formally investigated, is advised to rather lodge a formal protest/appeal as per the relevant GCR's within the stipulated time limits – www.kart.co.za/protest/.

15.8.3. Use of Footage and Privacy

- The sole purpose of the onboard footage is the control of driver conduct and enforcement of regulations by officials.

- The organisers/officials retain the right to use the footage for disciplinary, judicial or training purposes.
- Unauthorized publication or misuse of the footage by competitors may be considered a breach of sporting conduct as covered in 37.l. and 40.4.i.

16. SPORTING CHECKS AND SCRUTINEERING

- During the initial scrutineering and sporting checks, which will take place on the time and dates, and at the locations specified in the supplementary regulations of the event, each driver and each entrant must have all required documents and information available.
- Unless a waiver is granted by the Clerk of the Course in particular circumstances, drivers and entrants who do not keep to the time limits imposed will not be allowed to take part in the event.
- The Clerk of the Course and/or the Chief Medical officer may ask a driver (**or Entrant**) to undergo a medical examination or drug or alcohol test at any time during an event.
- All karts are checked by the Organizer in accordance with the SARMC Supplementary Technical Regulations and according to the RMC Global Technical Regulations 2026. However, if any kart is dismantled or modified in a way that might affect its safety or call into question its eligibility, or which is involved in an accident with similar consequences, must be re-presented for scrutineering approval.
- At any time during an event, the Scrutineers and/or Technical Consultant may:
 - check the eligibility of the kart or of the driver's equipment.
 - Require an entrant to supply them with such parts or samples as they may deem necessary.
 - The Clerk of the Course may require that any kart involved in an accident be stopped and checked.
- The Clerk of the Course will publish the findings of the scrutineers concerning all karts controlled and will place them at the disposal of other entrants on request. These findings will not include any specific figures except concerning fuel tests.
- Submitting a kart to scrutineering shall be considered as an implicit statement of conformity.
- Racing numbers are to be fitted front, rear and both sides, www.kart.co.za is to be fitted on front rear number plates and RMC South Africa logo prominently on the side face of each side fairing must be on the kart when the equipment is presented at scrutineering and must remain in place throughout the event.
- A driver is not allowed to change his / her equipment after it has been presented at scrutineering.
- Any contravention of the karting technical regulations or specifications will be deemed to afford an advantage, until the contrary is proven, and will generally result in automatic exclusion from the relevant race (in circumstances where it can reasonably be assumed that the contravention applied to the specific race only) or from the entire event/race meeting (in all other cases). The provisions of GCR 176 will only apply where, at the sole discretion of the appointed Technical Consultant (or alternate Official fulfilling a similar role), he/she refers the matter to the manufacturer of the relevant component/equipment manufacturer and said manufacturer confirms in writing that the referred contravention will not afford any performance advantage. Any such decision obtained from the applicable manufacturer shall be deemed to be final.
- Any component of a kart found not to comply with the technical regulations and specifications, must be impounded by the relevant Officials. The component may be returned to the competitor if the infringement is capable of being rectified (e.g. rear width of kart too wide) but only after an admission of guilt form has been filled in, signed by the competitor and submitted to, and accepted by, the Clerk of the Course. It is at the discretion of the Clerk of the Course to decide whether to return a non-compliant part, in consultation with the TC.
- A competitor removing a part/kart from parc fermé that is deemed to be the subject of a technical infringement, as pronounced by the relevant Race Officials without having signed an admission of guilt form, will automatically be excluded from the race/heat concerned (if it is clear that the infringement was only in respect of the particular race) or from the entire event (in all other instances). Any such exclusion shall be final, without the prospect of protest or appeal.

- m) In the event of a dispute concerning any item/component/part not covered in the relevant regulations or specification sheets, the Technical Consultant in consultation with the Rotax Technical Delegate/s (Ed Murray/Jan Habig) shall be empowered to make a ruling as to whether or not a contravention exists and, if found that one does, to recommend an appropriate penalty other than exclusion for imposition by the Clerk of the Course.

17. BRIEFINGS

Location of the competitors briefing/s will be published in the Supplementary Regulations.

The time of the briefing is defined in the programme of the event. The time stated is the beginning of the briefing. The meeting shall always be held before qualifying practice or the first qualifying heat.

Extra meetings may be organised if this is deemed necessary.

It is the Drivers / Entrants duty to enquire about time and place of the briefing and / or consecutive briefings. The time and location will be posted on the official Notice Board and available from the race office.

The presence of all concerned drivers/entrants is mandatory throughout the briefing

Any competitor/entrant failing to attend drivers briefing will be fined a **R 1 000,00** (one thousand) - or more which must be paid to MSA before he/she will be allowed to continue to compete in the event.

18. PARC FERME

- a) Only those Officials charged with the checks may enter the Parc Fermé. No intervention whatsoever may be carried out therein without the authorization of these Officials.
- b) As soon as the chequered flag is displayed (Finish), the Parc Fermé regulations will apply for the area between the Finish Line and the entrance to the Parc Fermé.
- c) The Parc Fermé shall be large and protected enough to ensure that no unauthorized person may have access to it.

19. SERVICING PARK

Only **ONE** driver per kart and **ONE** mechanic is allowed in "Servicing Parks" and only with proven passes. No karts/persons are allowed to enter "Servicing Park" with any liquids (except water in clear transparent plastic bottles, for drinking purposes).

20. PRE-GRID

- a) The pre-grid gate closes (three) **3-minutes** before race time. Any kart which has not taken its position on the pre-grid at that moment will not be allowed to do so, except under exceptional circumstances left to the discretion of the Clerk of the Course.
- b) Mechanics must clear the pre-grid immediately.
- c) Karts on the pre-grid must be ready to race, all further work and or adjustment/s (except for tyre pressure) to the kart on the pre-grid is strictly forbidden – **NO TOOLS – except tyre pressure gauge are allowed in this area**
- d) Any kart which needs mechanical assistance to start must do so at the rear of the grid and remain at the rear until after the race start irrespective of the number of formation laps.
- e) Karts on the pre-grid are prohibited to return to the service park before the start of the race.
- f) During qualifying, should a driver require assistant after the "30-second" signal has been given ~~in the~~ for timed qualification, his/her 2 best laps will be annulled.

21. RACE EVENT

Rotax Recommends the following format below.

NON -QUALIFYING PRACTICE:

The discipline applied in the Servicing Parks and on the track as well as the safety measures will be the same for all practice sessions as those applied for Qualifying Heats and the races of the final phase.

The time schedule of the event must provide a non-qualifying practice for each category. They are reserved for those drivers having passed the sporting checks and scrutineering. No Driver may take the start of qualifying and/or a Heat/Race without having participated in at least one Free Practice session. If there is a full grid of drivers, the drivers shall be divided into two series for odd and even numbers.

The use of transponders is mandatory from the beginning of the non-qualifying practice.

The number of non-qualifying sessions and time for each session will be defined by the organisers in the Supplementary Regulations.

The Clerk of the Course may interrupt Practice as often and for as long as he/she deems necessary for the clearance of the track or the removal of a kart. Further, if in the Clerk of the Courses opinion, the stop is deliberately caused by a Driver, the times he/she has achieved in that session may be cancelled, and he/she may be refused the authorisation to participate in any other Practice session. In the case of Free Practice only, the Clerk of the Course, may decide not to resume the Practice session after such an interruption.

Should one or several Practice sessions be interrupted in such manner, no protest relating to the possible effects of this interruption on the qualification of Drivers will be accepted.

QUALIFYING PRACTICE

A (ten)10-minute timed session for each class or a (three) 3- lap super pole.

Drivers must be on track (three) 3 min after Qualifying Practice started. If a driver is not on track after those (three) 3 min the driver will be disqualified from Qualifying Practice.

Any driver who has not participated in the Qualifying Practice may request in writing to the Clerk of the Course the authorization to continue in the race. The Clerk of the Course will decide according to the circumstances of the absence in the Qualifying Practice. There will be no protest allowed into the Clerk of the Courses decision.

STARTING GRID

At the end of the final Qualifying Practice session, the list of qualified Drivers as well as the starting grid positions will be officially published.

Only these Drivers will be allowed to take the start of the Qualifying Heats or Prefinal and/or of the final phase.

Any competitor whose kart(s) is (are) unable to take the start for any reason whatsoever or who has good reasons to believe that his/her kart(s) will not be ready to take the start must inform the Clerk of the Course.

The grids will be drawn up in accordance with the fastest time achieved by each Driver, taking into account the Qualifying Practice session(s). Should one or several Drivers achieve the same time, the tie will be settled on the basis of their second-best time, and so on.

The pole position Driver of each grid will have the choice of the pole position (on the left or right side of the track), providing that he advises the Clerk of the Course as soon as he reaches the "Pre-Grid". This choice will only modify the first row, to the exclusion of the others. Failing this, the pole position Driver of each grid will take the start of the Race from the grid position designated in the Supplementary Regulations of the event.

Access to the Pre-Grid area from the servicing park will end as stated in the official timetable. Any kart which has not taken its position on the "Pre-Grid" at that moment shall not be allowed to do so, except under exceptional circumstances left to the discretion of the Clerk of the Course

Any Driver present, with his/her kart, on the pre-grid within the time limit will be considered as a starter.

22. STARTING PROCEDURE

The start signal should be given by means of lights or MSA flag as per event SR's.

All categories will have rolling starts with the exception of E20 which will be standing start only.

The regulations for "Rolling start for karts with clutches and without gearbox" of the FIA Karting general regulations apply. The grid being constituted of two lines of karts.

Two (two) 2-meter-wide lanes bordered by white lines will be painted over the (one hundred and ten) 110 meters leading to the start line. A yellow line shall be painted (twenty-five) 25 m ahead of the start line.

Drivers may only restart themselves and no assistance may be given.

Any driver who is present, with his/her kart, on the grid within the time limit will be considered as a starter.

As soon as the Clerk of the Course indicates with the green flag that the karts may take the start, the drivers are «at the orders of the Clerk of the Course and may no longer receive any outside assistance. Any driver who has not placed himself/herself at the orders of the Clerk of the Course in time with his kart in working order will be allowed to leave the pre grid only at the orders of the Clerk of the Course or of the Official in charge of the pre grid area.

The number of formation laps for all categories to be defined in briefing.

According to the instructions given at the Briefing, karts will cover approximately (1) one Formation Lap before the start may be given. It is forbidden to overtake another Driver under pain of a penalty inflicted by the Stewards (10 (ten) seconds or disqualification from the Heat/Race).

If a driver stops for any reason during the formation lap, he/she will not be allowed to start again before he/she has been passed by the entire field. He/She shall start again from the back of the field . Should he/she try to start ahead of the field in the hope that the leading drivers overtake him/her, he/she will be shown the black flag and be excluded from that heat/race.

A driver who is delayed will have the possibility of regaining his grid position only if this manoeuvre does not impede other drivers, and in all cases before having reached the red line which will be marked on the track, equipped with a time keeping loop and indicated by the Clerk of the Course at the briefing. It is forbidden to use any course other than the track used during the race to regain his/her start position.

If the Clerk of the Course considers that a Driver has been immobilised as a result of another Driver's mistake, the Clerk of the Course may stop the Formation Lap and start the Starting Procedure again, on the basis of the original grid or allow the impeded Driver to regain his/her position.

As soon as Clerk of the Course is satisfied with the formation, he/she will give the start instruction by switching off the red lights. If he/she is not satisfied with the procedure, he/she will switch on the orange light, which means, that another Formation Lap must be covered.

At the end of the Formation Lap (number defined in supplementary regulations), Drivers will proceed ~~forward~~ at a reduced and constant speed towards the Starting Line, lined up in two lines of karts, and each line shall remain within the lanes marked on the track. A Driver crossing the lanes before the lights have been switched off, is liable to be sanctioned by the Stewards, on the basis of a time penalty of (three) 3 seconds for partly crossing the lanes and of (five) 5 seconds for completely getting out of the "corridor". When the karts

approach, the red lights will be on. No karts may accelerate before the red lights have been switched off. Karts must maintain their position until the start signal is given.

If the Clerk of the Course is satisfied with the formation, he will give the start by switching off the red lights. If he/she is not satisfied with the procedure, he/she will switch on the orange light, which means that an extra formation lap must be covered. Should the engine of a driver stop during formation lap, an Official or mechanic nominated to carry out that task may restart the competitor as soon as he/she has been passed by the entire field. The competitor may then re-join at the back of the formation and must not try to regain his grid position. If the kart cannot be started, then it must be removed from the track to a place of safety. Similarly, should a driver fall behind the entire field without stopping, he/she must remain at the rear for the field and must not attempt to regain his/her position.

In the case of repeated false starts or incidents during the formation lap(s), the Clerk of the Course, may stop the starting procedure by means of the Red flag and inform the Stewards, who will be entitled to impose a penalty on the offending driver/s according to the FIA Karting General Prescriptions. A new procedure will begin either immediately or within (thirty) 30 minutes, according to the circumstances. The starting grid will be the same as for the initial procedure. All the drivers present in the starting area or in the repair area before the procedure was stopped will be allowed to take the start of the new formation lap.

Any attempts to jump the start or delay it and any karts leaving the lane before the lights are switched off shall be sanctioned according to FIA Karting General Prescriptions.

A Jump Start will be deemed to have occurred when a driver crosses the start line ahead of his/her prescribed grid position at the start of the race. Officials will determine if a jump start has been committed. For the penalty, refer to the FIA Karting General Prescription.

As soon as the start has been given, racing conditions are applied and, irrelevant of the position of a kart on the track, it is forbidden to give it any assistance, except for placing it in a safe location when required.

The Stewards may use any video or electronic system likely to help them to take a decision. The Steward's decisions may supersede those taken by Judges of Fact. Any infringement to the provisions of the code or of these sporting regulations relating to the starting procedure may entail the exclusion of the competitor/s concerned from the race/heat or event.

Only MSA Officials will be allowed to give assistance.

START DELAYED.

If the Clerk of the Course considers for safety reasons that the start must be delayed, the following procedure will take place.

- a) A time will be given where change can be made.
- b) Entrants/drivers outside this time will not be able to start the race.
- c) By tyre change:
 - The width of the rear and front wheel may be adjusted but must conform to FIA Karting Technical Regulations.
 - No other modifications and/or changes are permitted.

STOPPING / RESTARTING A RACE

The procedure which will be used should it become dangerous to continue the race will be suspended by the showing of red flags and, if appropriate, resumed with a "SLOW" process as described in Article 22.1 below.

Note

No reserve karts are permitted in the Servicing Park.

The race classification will be the finishing order at the showing of the chequered flag at the end of the resumed race.

Should it become necessary to stop the race or practice because the circuit is blocked by an accident or because weather or other conditions make it dangerous to continue, the Clerk of the Course shall order a red flag to be shown on the start / finish line. Simultaneously, red flags will be shown at marshal's posts provided with these flags. The decision to stop the race or practice may be taken only by the Clerk of the Course (or, if he/she is busy with other matters, by his/her deputy).

If the signal to stop racing is given:

Case A: during practice, all karts shall immediately reduce speed and go back slowly to the post-race paddock and await further instructions from the Officials All karts abandoned on the track shall be removed.

Case B: during the qualifying heats, all karts will immediately reduce their speed and go to the post-race paddock and await further instructions from the officials or stop on the track at the place designated during the briefing, considering that:

The classification of the race will be the classification at the end of the lap prior to that during which the signal to stop was given –

Reason for a race stoppage could be and not limited to:

- karts or rescue vehicles may be on the track - the circuit may be totally blocked because of an accident
- the weather conditions may have made it impossible to drive at high speed on the circuit.

The procedure to be followed varies according to the number of laps completed by the race leader before the signal to race stoppage occurred:

- less than (seventy-five)75% of the race/heat distance scheduled for the race (rounded up to the nearest higher whole number of laps). If the race can be restarted, the article of the FIA Karting General Prescriptions will apply.
- (seventy-five)75% or more of the race/heat distance scheduled (rounded up to the nearest higher whole number of laps). The karts will proceed to the Park Fermé area, and the race will be considered as having stopped when the leading kart crossed the line at the end of the lap prior to that during which the race stoppage signal was given.

Case C: during a race of the final phase, all karts will immediately reduce their speed and go to the to the Park Fermé area or stop on the track at the place designated during the drivers briefing, considering that:

Reason for a race stoppage could be and not limited to:

- the classification of the race will be the classification at the end of the lap prior to that during which the race stoppage was given
- karts or rescue vehicles may be on the track
- the circuit may be totally blocked because of an accident

- the weather conditions may have made it impossible to drive on the circuit at racing speed.

The procedure to be followed varies according to the number of laps completed by the race leader before the signal to stop the race was given:

- Less than (two) 2 laps. No points will be awarded. If the race can be restarted, the article of FIA Karting General Prescriptions will apply.
- More than (two) 2 laps but less than (seventy-five) 75% of the distance scheduled for the race (rounded up to the nearest whole number of laps). If the race can be restarted, the article of FIA Karting General Prescriptions will apply. Should this not be possible, half the points will be awarded.
- (seventy-five) 75% or more of the race distance (rounded up to the nearest whole higher number of laps). The karts shall be sent directly to the Park Fermé, and the race will be deemed to have finished when the leading kart crossed the line at the end of the lap prior to that during which the race was stopped. Full points will be awarded.

Restarting a race (Qualifying heats or final races)

- Working on karts will be allowed only in the Repair Area; the only persons allowed to work on a kart are the Driver himself and his appointed Mechanic, holder of the appropriate pass. Refuelling will not be allowed.

All karts must be ready at the (three) 3 minutes board.

- After a suspending race stoppage situation, the delay will be kept as short as possible and as soon as resuming time is known, Drivers will be informed. In all cases at least a (ten) 10-minute warning will be given. Boards will be presented (ten) 10 minutes, (five) 5 minutes, (three) 3 minutes, (one) 1 minute and (thirty) 30 seconds before the resumption. Each signal will be accompanied by an audible warning.
- The Race or Heat will be resumed with the "SLOW" process and Article 2.20 (FIA Karting General Prescription). The length of the new race will be equal to the difference between the scheduled number of laps and the number of laps covered. The Drivers who have crossed the Finish Line at the end of the lap prior to that on which the race was stopped and those who were in the Repair Area when the Red flag was shown will be allowed to take the new start.
- Resuming start positions will be determined by the finishing order at the end of the lap before the one on which the race stoppage was signalled

RESUMING A RACE WITH "SLOW PROCESS"

If a Race is suspended, the resuming procedure will be conducted with the "SLOW" process.

At the order of the Clerk of the Course, Drivers will proceed to start in a neutralised situation for one or more laps. The Marshals' Posts will display "SLOW" boards with static yellow flags.

If the formation is satisfactory, the Clerk of the Course will signal the resuming of the Race by means of a waved green flag at the start line.

Overtaking will remain prohibited until the karts have crossed the start line.

On approaching the start line, where a green flag will be waived by the Starter or the Clerk of the Course, the Drivers may accelerate only after crossing the yellow line preceding the start line. The yellow flags and the "SLOW" boards at the Marshals' Posts will then be withdrawn and replaced by waved green flags. These flags will be displayed for a maximum of one (1) lap.

RESTART PROCEDURE

a) LESS THAN TWO LAPS

The original start will be deemed null and void and all competitors who are able to restart the race will do so in their original grid positions – a normal start procedure will be adopted. The length of the new race will be the full original race distance.

- b) MORE THAN 2 LAPS BUT LESS THAN 75% OF THE RACE DISTANCE** (Rounded up to the nearest higher whole number of laps)

If the Race can be resumed (at the discretion of the Clerk of the Course (or, if he had to leave, by his deputy). The single file grid will be determined by the finishing order when the leading kart crossed the start line at the end of the lap prior to that during which the Race was stopped. Only karts in the Repair Area at the time when the Race was stopped by the Red flag, will be allowed to take the restart. Should a restart of a race in the final phase not be possible, half Championship points will be awarded for this race.

- c) NO RESTART PROCEDURE**

75% OR MORE OF THE DISTANCE OF THE RACE (Rounded up to the nearest higher whole number of laps).

The race will be called complete – the classification of the Race will be the classification at the end of the lap prior to that during which the signal to stop the Race was given. In case of a race in the final phase, full Championship points will be awarded for this race.

23. DEAD HEATS BETWEEN DRIVERS

If two or more competitors finish the season with the same number of points, the highest place in the Karting Championship held over a series of Competitions (in either case) will be awarded to:

- a) the holder of the greatest number of first places in the national races for National Championship and regional races only for a Regional Championship.
- b) if the number of first places is the same, the holder of the greatest number of second places as above applies,
- c) if the number of second places is the same, the holder of the greatest number of third places and so on until a winner emerges.
- d) if there is still a dead heat, the better position in the final race of the last event will be decisive.

24. SCALE / WEIGHING PROCEDURE

- a) The official scale of the day will be located in the Parc Fermé area. This is the only scale that will be officially recognized and used for all measurements. This scale is the **ONLY** one which will be officially used and counted. The scale will be available from the first non-qualifying session.

After Qualifying Practice, the Qualifying Heats and the races of the final phase, each kart crossing the Line will be weighed. If the kart is unable to reach the Weighing Area by its own means it will be placed under the exclusive control of Marshals, who will take it there or have it taken there, and the Driver shall report to the Weighing Area before he/she returns to the pits so that his/her weight may be established.

- b) Competitors need to stand on the scale with all racing safety equipment.
- c) No solid, liquid or gaseous matter or substance of any nature whatsoever may be added to a kart, placed on it or removed from it before Weighing (except by a Scrutineer/TC within the framework of his official duties).
- d) Other than the competitor, only Scrutineers/TC and Officials may be in the Weighing Area. No intervention whatsoever is allowed in that this area, unless it has been authorised by these Officials.
- e) Neither the competitor or his/her kart allowed to leave the Weighing Area without the authorisation of the Technical Consultant (or Scrutineer).
- f) Any infringement to these provisions relating to the Weighing of karts may entail the imposition of a penalty on the competitor concerned.
- g) If the weight of a competitor and of his/her kart (combined) is under that specified in the Technical Regulations, the result will be communicated in writing to the entrant/competitor, and competitor will be excluded from the Qualifying Practice session or from the Qualifying Heat concerned or, in the case of a final phase Race, as a minimum classified last (Without allocation of any Championship points, if applicable).

- h) Drinking water from a clear plastic bottle is allowed in the servicing park after weighing (if approved by the TC however any driver pouring water over his/her head and race overall will be penalized with 1 (one) KG being deducted from the weight measured of the kart and competitor combined.

25. FRONT FAIRING

The use of a FIA Karting homologated Front Fairing and the FIA Karting homologated Front Fairing Mounting Kit of the bodywork of latest homologation period is mandatory, in accordance with CIK Specific Prescriptions, article 30 and FIA Karting homologated Technical Drawing No 2d. The provisions of FIA Karting homologated Specific Prescriptions, article 30 regarding mounting, installation, checking, reporting of breaches and application of penalties will be applied in full.

The front fairing must be in the correct position at all times during a competition according to the FIA Karting homologated technical regulations. If an official reports that the front fairing on one or more karts was no longer in the correct position when the “black and white chequered flag” was waved and the kart(s) concerned crossed the finish line, in all situations a time penalty of five (5) seconds (for heats and races) or a drop down of three positions in qualifying practice sessions will be imposed automatically on the driver(s) concerned. This time penalty is not susceptible to appeal (in application of Art. 12.2 ISC). When the official send the reports regarding the incorrect position of the front fairing, the Stewards will automatically apply the decisions. The stewards can also do a collected decision for the involved competitors in a session. The entrants/competitors concerned shall not be invited to sign the decision documents. Should a competitor or a third party be found/proved to have intentionally adjusted/replaced a front fairing which is not installed correctly during the last lap or after the “black and white checkered flag” was waved, this will lead to a disqualification.

DESSIN TECHNIQUE N°2.2

Kit de montage de carénage avant - Groupes 1 & 2

TECHNICAL DRAWING No. 2.2

Front fairing mounting kit - Groups 1 & 2

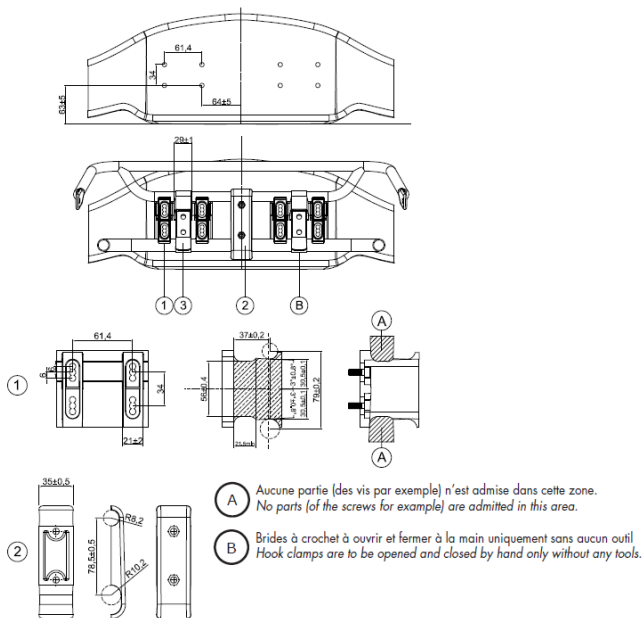

DESSIN TECHNIQUE N° 2.2.1

Installation correcte du «Carénage Avant» - Groupes 1 & 2

Position correcte / Correct position

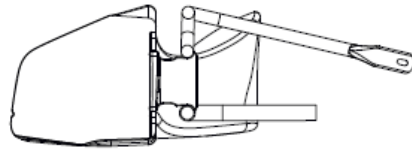

TECHNICAL DRAWING No. 2.2.1

Correct installation of the "Front Fairing" - Groups 1 & 2

Position acceptable / Acceptable position

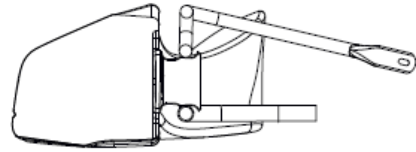

Position non acceptable si une quelconque partie des tubes du pare-chocs avant se trouve dans les zones marquées (A).

Not acceptable position if any part of the tubes of the front bumper are in the marked areas (A).

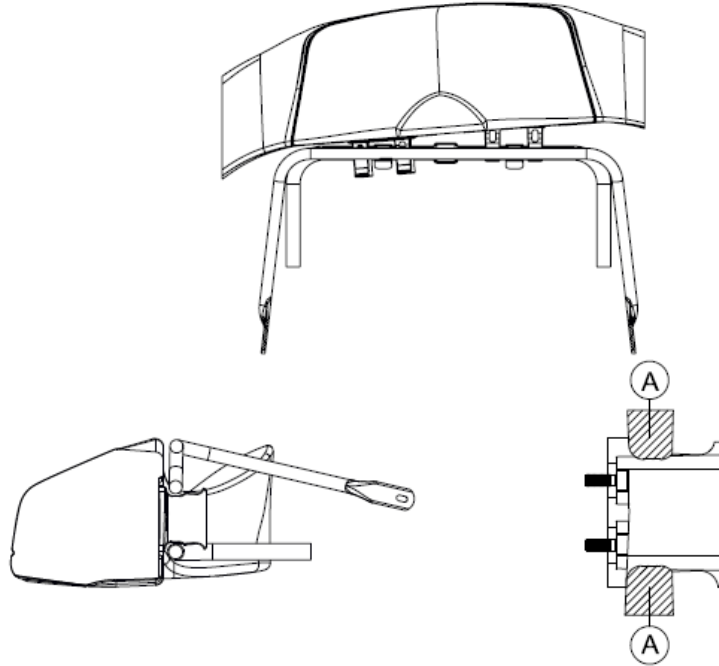

26. EVENTS COUNTING TOWARDS THE SARMC AND POINT SCORING

The SARMC series points are calculated by adding the regional participation bonus points to your national points with the following formula.

Regional Participation Bonus Points:

- A competitor will score participation points in the SARMC events in the region in which he/she resides. Nomination of a different region must be applied for and approved in writing by the Championship co-ordinator before the first SARMC point scoring event of the competitor concerned failing which the competitor will only score in the region in which he/she resides.
- Each region nominates four (4) rounds of their Regional Championship in agreement with the Championship co-ordinator as SARMC scoring events. **(Where a region does not hold regional championship status events, they may apply for four (4) of their Club Championship events to count)**
- Competitors who take part in SARMC Regional events will receive 1 (one) bonus point for each race started.

National Points:

- The first three (3) National rounds each have time trials and 3 (three) point scoring finals.
- The fourth and final National event has time trials and 4 (four) point scoring finals.
- The best 10 (ten) finals out of a possible 13 (thirteen) finals at National events count.

Important Note!

- k. Final(s)/ points: A starting grid of max. 34 (thirty-four) drivers and the race of min. 15 (fifteen) km or 15 (fifteen) minutes. Score-points 35, 32, 30, 29, 28..... to last placed finisher. Non-finish: minus 5 points off last finisher.
- l. Exclusions score zero points.
- m. Important Note about Apex Timing Software
The Apex Timing System shows “DSQ” when a driver is excluded. This does not mean they are disqualified. Only MSA or FIA can give a disqualification.

Final Classification

The Championship results as calculated above will determine the

- Rotax South African National Champions
- Competitors qualifying for invitations to the RMC

The points standings in the SARMC will be published on the www.motorsport.co.za and www.kart.co.za website.

Trophies will be awarded in each class for at least the first three (3) finishing competitors of the final of the SARMC 2026 events and series.

27. COMBINING OF CLASSES

- a) It is permitted to combine Rotax classes up or down according to the Rotax ranking so Micro Max combines with Mini Max; Junior Max with Senior Max DD2 with DD2 Masters. SARMC scoring races may not combine Rotax classes with non-Rotax classes.
- b) Regions are requested in 2026 to always run above combinations together in practice and racing.
- c) Under no circumstances ever, should Bambino class be combined with any other class.**
- d) Grid should be staggered with the higher ranked class starting first.
- e) The results will be scored by means of the “class within a class system” for DD2 and DD2 Masters as follows: All finishers are scored in the higher-ranking class first. The higher ranked class is then removed and the lower ranked rescored.
- f) If there is strong support in a region for both classes in a combined category, organisers may run these classes separately.
- g) These principles are applied to promote better value for both competitors and spectators. It also will assist to have more practice time and shorter race days.

28. PODIUM CEREMONY

The drivers classified 3rd, 2nd and 1st as determined in according with the Standing Supplementary Regulations (SSR’s) of each Championship shall climb on the podium one after the other.

The first 3 competitors must wear their overalls zipped up at prize giving ceremonies.

If caps are supplied by the organiser of the 2026 RMC, they must be worn by the competitors during the podium ceremony.

All competitors/entrants agree that ROTAX and its sponsors may use photographs or videos of RMC races (including names and photographs of drivers) for advertising, publicity and public relations purposes.

29. NOTIFICATIONS BY THE COC OR THE STEWARDS DECISIONS TO DRIVERS / ENTRANTS

Competitor / Entrant will be sent electronically to the Competitors / Entrant’s mobile phone using an application developed by ROTAX for this purpose, named ROTAX GLOBAL or relevant group, or will be published on the official notice board in the event of electronic communication problems (load shedding).

30. HOW THE ROTAX GLOBAL APP WORKS

The ROTAX GLOBAL APP is free of charge and is available for download for IOS and Android.

The ROTAX GLOBAL APP requires internet access.

During competitors' registration process, the competitor / entrant will get his own and unique QR code (also known as EDIT code). With this code, competitor / Entrant will register in his/her mobile phone and the system recognizes that those are the registered persons as the official receivers of the notifications.

It is the responsibility of competitor / Entrant to keep this code confidential.

This ROTAX GLOBAL APP will communicate with the EVA Event Management system (EMS).

The EMS is the communication platform used internally by the organizer and the stewards and it will record the time that all the information / notifications will be sent to competitor / Entrant and the time when the competitor / Entrant read the notification.

31. COMMUNICATION FLOW

The Clerk of the Course or Stewards will send the notification or decision via EMS to the competitor / Entrant and all the registered users will get this information immediately on their mobile phone.

When competitor or Entrant reads the notification, the EMS immediately records the time at which the notification was read, thus officially confirming the notification sent to the competitor / Entrant.

During competitor registration, the organizer will provide all the important information how to use the App and how to register.

At the competitor Registration, the competitor / Entrant will sign a document stating that he/she will be responsible to register in the ROTAX GLOBAL APP.

All starting numbers for which he/she is responsible as an Entrant must be checked with due diligence to ensure that he/she receives any notifications, and to guarantee that, during the event period, his/her mobile phone remains connected to the network.

The Competitor/ Entrant must register with the QR code given to them during the driver's administration.

In case of loss, damage or battery failure of the mobile phone, it is competitors/Entrant's responsibility to register with another mobile phone, in order to assure he/she will receive the notifications of the Clerk of the Course or Steward's decisions.

In the event of internet failure in the paddock area, the Entrant / competitor will be notified personally.

32. INSTRUCTIONS AND COMMUNICATIONS TO COMPETITORS/ENTRANTS

All classifications and results of qualifying practice, the qualifying heats and the race(s) of the final phase, as well as any decisions of the Officials of the event will be sent to the ROTAX GLOBAL APP and posted on the official WhatsApp notification board.

33. FINES

A fine may be inflicted on any entrant, competitor, assistant, organizer who does not respect the prescriptions of the Officials of the event.

Fines imposed by the Clerk of the Course or the Stewards must be paid to MSA as per the relevant GCR's.

34. PROTEST AND APPEALS

Incident Reports will not be accepted by the Officials and any competitor who considers himself/herself sufficiently aggrieved, and requires an issue to be formally investigated, is advised to rather lodge a formal protest/appeal as per the relevant GCR's within the stipulated time limits.

By entering events in the SARMC competitors agree that time is of the essence and that a protest will only be heard if they are submitted strictly in accordance as per MSA GCR Part IX. The protest must be accompanied by the appropriate fee.

35. PADDOCK RULES

A Paddock Observer will be appointed as a Judge of Fact in respect of the following paddock rules:

Starting of engines is only allowed in the designated area / Servicing Park and engines may only be run in the designated area / servicing park for a maximum of 5 seconds. A competitor and/or his/her crew or entrant starting an engine outside these areas, or exceeding the permitted running time, will be penalized with a fine of R 1 000.00 (one thousand). A second offence may lead to exclusion.

It is strictly forbidden to smoke or to use any device which risks provoking fire in the Paddock area, the Servicing Parks, the Parc Ferme, the Assembly Area, on the starting grid or on the track (along the course). Offenders, including Officials, will be penalized by a fine of **R 1 000. 00 (one thousand)** and may be asked to leave the venue. This includes the use of electric cigarettes / vaporisers.

It is forbidden to cook in the Paddock, except with a special authorization from the Organizer.

Children under the age of 7 (seven) years who are not permanently accompanied by a adult, will not be admitted in the Paddock Area.

It is forbidden to use motorized vehicles (except authorized by the Organizer) such as mini- motorcycles, scooters etc., in the Paddock Area under the pain of exclusion.

36. FIRE EXTINGUISHERS

For safety reasons the organizer will provide all the servicing park area and pre-grid with the necessary and sufficient quantity of fire extinguishers.

Every competitor must have a serviced fire extinguisher (with in the previous 12 (twelve) months) of at least 1.5 (one point five) Kg. These extinguishers must be presented at scrutineering and must be secured to the kart trolley.

37. CODE OF CONDUCT FOR DRIVERS

- a) All participants must play within the rules and respect race Officials and their decisions.
- b) All participants (Competitors, Entrants, Mechanics, Officials) must respect the rights, dignity and value of their fellow participants regardless of gender, sexual orientation, ability, physical appearance, race, skin colour, language, political opinion, family disability, cultural background or religion.

There is absolutely NO TOLERANCE for the manifestation of discrimination toward above mentioned.

- c) All participants must encourage and take responsibility for their actions at all times.
- d) All participants must ensure their equipment is safe and race worthy, prior to taking part in training, testing or race events. Only approved racewear (e.g.: helmet, gloves, race boots and suit) to be used by the driver, according to the regulations.
- e) It is the participants own responsibility to identify and measure his/her own skill level against his/her competitors, and take responsibility for the risks associated with training, testing and or racing. It should be noted that a basic level of competence is required.
- f) It is the participant's responsibility to declare, prior to any participation in training, testing or racing, of any medical condition or medication required that may be relevant in the event of an emergency.
- g) All participants are required to display courtesy and etiquette to other members and participants in training, testing and race events. Any disputes or problems that may arise during an event must be addressed in a respectful manner, to the correct person (Official) at the event.

- h) The safety of children within the sport is a priority. Knowledge of the code of ethics surrounding care of children in sports will be promoted and encouraged. It is the participant's own responsibility to ensure the safety of children at training, testing or racing events. Refer to the MSA Safeguarding Policy.
- i) When taking part in any event, it is the responsibility of the driver to take the time to read and fully understand the posted rules, regulations and conditions for said event prior to start time, thus eliminating unnecessary delays at the beginning of the event. Requests for clarification of these rules, regulations or conditions, should be asked in the drivers meeting held before each event.
- j) All participants must have respect for the environment and the surrounding inhabitants. Responsibility must be taken to reduce excessive noise and keep all areas that are used as clean and pollution free as possible.
- k) All participants must respect that drugs and alcohol are strictly prohibited at training, testing and races. It is an offence and will not be tolerated. Offenders will be excluded from the event and face further disciplinary action.
- l) Any abusive comments on social media (Facebook, Twitter etc.) between teams, competitors, officials, organizers, or any person associated with ROTAX, will be held responsible and liable for their actions.

38. GENERAL SAFETY

- a) It is strictly forbidden for Drivers competitors and/or officials to drive their karts/service vehicles in a direction opposite that of the race unless expression instruction to do so is given by the Clerk of the Course to do so.
- b) During Free Practice (according to the regulations of the Championships concerned), Qualifying Practice, the Qualifying Heats and the races of the final phase, competitors may use the track only and must at all times observe the dispositions of the Code relating to driving on circuits. The circuit is defined by the white lines on both sides of the track. Competitors are allowed to use the whole width of the track between these lines. If the four (4) wheels of a kart are outside these lines, the kart is considered as having left the track.
- c) During Free Practice (according to the regulations of the Championships concerned), Qualifying Practice, the Qualifying Heats and the races of the final phase, a kart that stops, it must be removed from the track as rapidly as possible in order for its presence not to constitute a danger or be an impediment for other competitors. If the competitor is unable to remove the kart from a dangerous position by driving it, it is the marshals' duty to help him/her; however, if the kart restarts as a result of such help, it will be disqualified from the classification of the Qualifying Practice or the race in which this help was provided. Except for medical or safety reasons, the competitor must stay close to his/her kart until the end of Free Practice, Qualifying Practice, the Qualifying Heat, or the races of the final phase. In the case of a Practice session run over two parts separated by an interval, all karts abandoned on the circuit during the first part must be taken back to Parc Ferme during the interval and may participate in the second part of Practice.
- d) Any repairs with tools are banned outside the "Repair Area ". It is forbidden to take any tools and/or spare parts on board the kart. The competitor can receive help only in the "Repair Area" determined by the event Supplementary Regulations (SR's) or during the competitors Briefing/s.
- e) If refuelling is authorised, it may be carried out only in an area provided for this purpose.
- f) Except in cases expressly provided for by the Regulations or by the Code, no one except the competitor is authorised to touch a stopped kart unless it is in the "Repair Area ".
- g) When the track is closed by the Clerk of the Course during and after Practice and after the finish until all concerned karts whether they are mobile or not, have arrived at the "Finish Park" or at the Parc Fermé, no one is allowed to access to the track, with the exception of marshals carrying out their duties and of competitors when they are driving.
- h) During Free Practice (according to the regulations of the Championships concerned), Qualifying Practice, the Qualifying Heats and the races of the final phase, the kart may be restarted only by the competitor himself/herself, except if he/she restarts from the "Repair Area ". The competitor may not receive any

outside help on the track during the running of a Competition, except in the “Repair Area”, which he may reach only by his own means. Pushers are not allowed to help Drivers once they have crossed the line drawn at the exit of the “Pre-Grid”.

- i) A speed limit may be imposed in the pit lane and in the “Repair Area” during Practice, races, and the Formation Laps. Any competitor breaking this speed limit will be imposed a penalty provided for in the Regulations, or at the discretion of the Stewards if a regulation is not specified in the event SR’s or via a Bulletin.
- j) If a competitor is faced with mechanical problems during Practice, the Qualifying Heats, or the Races of the final phase, he must evacuate the track as soon as possible for safety reasons.
- k) If a competitor is involved in a collision, he must not leave the circuit without the Stewards’ agreement.
- l) No competitor may leave the “Repair Area” without having been instructed to do so by the Marshals.
- m) Official instructions will be given to the competitor by means of the signals provided for in the Code, these regulations or Appendix H. Competitors crew must not use flags similar to these ones in any way whatsoever.
- n) Any competitor who intends to leave the track, to enter Parc Ferme, or to stop in the “Repair Area” shall demonstrate his/her intention by raising their hand in due time and shall ensure that he may do so safely.
- o) During the Competition and at the order of the Clerk of the Course, a competitor who breaches the Technical Regulations, except during the final lap, must stop in the “Repair Area” and rectify the breach before re-joining the track.
- p) When participating in Free Practice (according to the regulations of the Championships concerned) or Qualifying Practice, in the Qualifying Heats or the Races of the final phase, a competitor must at all times wear all the equipment as defined under Article 3 of the Technical Regulations.
- q) It is forbidden to circulate with motorbikes, scooters, or any other motorised devices in the Paddock. The starting up, running in, warming up or testing of kart engines in the Paddock as well as in the Reserved Areas (see Article 20 of the International Sporting Code) is strictly prohibited. Offenders will be penalised by a fine of minimum R 2 500.00 (two thousand five hundred) In the event of repeated breach, the stewards may disqualify the competitor/s concerned. In application of Article 12.2.3 of the Code, appeals against the stewards’ decisions have no suspensive effect when in the course of the same Competition, a further breach is committed justifying the disqualification of the same Competitor.
- r) The Organiser undertakes to have ~~on~~ at the track/venue all safety devices provided for meetings the Circuit Regulations, Part 2, from the beginning of Free Practice until the end of the event
- s) In the case of a «wet race» (conditions signalled by means of a panel by the race officials, the choice of tyres will be left to the appreciation of the Drivers, the Clerk of the Course reserving the right to use the black flag if he deems that a Driver’s kart is fitted with the wrong set of tyres and that the Driver is too slow and dangerous for other Drivers. The use of “slick” tyres is therefore mandatory in any other case.
- t) General Safety. FIA Karting International Karting Regulation, General Prescription Article 2.14
- u) The starting up, running in, warming up or testing of kart engines in the Paddock as well as in the Reserved Areas (see Article 20 of the International Sporting Code) is strictly prohibited. Offenders will be penalized by a fine of minimum R 2 500.00 (two thousand five hundred). In the event of repeated breach, the Stewards may disqualify the competitor concerned from the event. In application of Article 12.2.3 of the Code, appeals against the stewards’ decisions have no suspensive effect when in the course of the same Competition, a further breach is committed justifying the disqualification of the same Competitor.
- v) Kart Safety. FIA Karting International Karting Regulation, Technical Regulations Article 3
- w) Equipment Safety. FIA Karting International Karting Regulation, Technical Regulations Article 3 and 3.2

39. PENALTY CATALOGUE

Participants, who commit an irregularity, shall be punished with a penalty according to the below regulations as well as possible imposition of LPS points as per Article 35.

breaches and penalties below do not restrict the Clerk of the Course or the Steward (in the case of a protest) from imposing further penalties, in accordance with the general regulations, if they deem the incident justifies

it.

Leaving corridor: If a driver leaves the corridor (lines) before the start was given the following penalties will count:

Case A: 1 (one) to 2 (two) tyres out of corridor time penalty 3 (three) seconds

Case B: more than 2 (two) tyres out of corridor time penalty 5 (five) seconds

Time penalty 5 (five) seconds: In addition to the CIK-FIA General Prescriptions the Clerk of the Course has the power to decide a 5 (five) second penalty. The penalty will be shown with the black and white flag in connection with the start number and a board 5 (five) seconds at the start/finish line. During the 2 (two) last laps no flags will be shown, the Clerk of the Course informs during the briefing on the procedure for the imposition and notification of these penalties. If there are more offences of the same driver in the same session, the Clerk of the Course will report that to the Stewards for possible further punishment.

It is not possible to protest these decisions. (In application of Art. 12.2 ISC).

In case a driver has 2 penalties, “front fairing” and “5 seconds Clerk of Course decision” in the same session, both penalties should be added to the results.

5 (five) seconds penalties can be given for the following:

- Unfair driving behaviour,
- Dangerous driving behaviour,
- Ignoring the yellow flag, - blocking another driver to avoid overtaking,
- Not following the instructions of the Stewards of the meeting or the Clerk of the Course,
- Leaving the corridor before the start,
- 2 (two) tyres – 3 (three) seconds
- More than 2 (two) tyres – 5 (five) seconds - Causing a false start,
- Not following the specific instructions mentioned during the drivers briefing/s.

For any incident that is not mentioned, but deemed incorrect by the Clerk of the Course, a sanction can be proposed by the Stewards of the meeting. The above-mentioned incidents can also remain. Tyres mounted in the wrong driving direction: If a competitor is detected in the “pre-grid area” with tyres mounted in the wrong driving direction, he/she will be moved to the repair area/zone, were there he/she must mount his/her tyres correctly. Afterward the correction has been made, he/she can take the start of the session, first when the start was given at the start/finish line, he/she is not allowed to follow the formation before the incorrectly mounted tyre are corrected.

The following penalty catalogue is only a recommendation.

#	DESCRIPTION	PENALTY
39.1	Gaining an Unfair Advantage	5 (five) seconds
39.2	Driving in a manner incompatible with general safety – e.g. causing an accident	Minimum 5 (five) seconds up to 10 (ten) seconds, Race or Meeting exclusion
39.3	Contravention of flag signal before or after Race - Black & White / Yellow	5 (five) seconds
39.4	Contravention of flag signal during Race – Black & White / Yellow	Minimum 5 (five) seconds up to 10 (ten) seconds
39.5	Contravention of flag signal - Ignore Technical Flag Twice	Black Flag
39.6	Contravention of flag signal – Red Flag or Black Flag	Race or Meeting exclusion
39.7	Abusive Language, Behavior or Assault	Race or Meeting exclusion
39.8	Failure to attend Drivers' Briefing	Fine of R 1 000.00 (one thousand)
39.9	Failure to obey an Official of the Meeting	Race or Meeting exclusion
39.10	Scrutineer Non-Compliance Report, vehicle or component ineligible	Race or Meeting exclusion See Article 15.j-m
39.11	Underweight	Race exclusion
39.12	Failure to report to Scrutineering	Race Meeting exclusion
39.13	Incorrectly positioned front fairing - Qualifying practice	Drop down of three positions
39.14	Incorrectly positioned front fairing – race	5 (five) Seconds penalty
39.15	Attempting to tamper with or reattach the front fairing during race / timed qualifying	Race exclusion
39.16	Intentionally reattaching the front fairing after checkered flag	Meeting Disqualification & Consideration of Referral to MSA

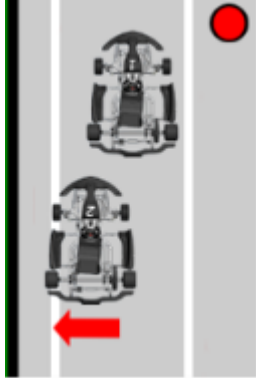
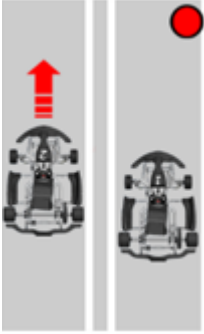
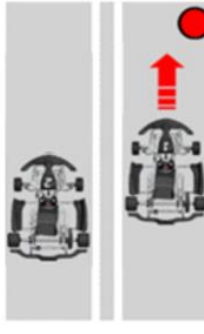
<p>39.17. FALSE START (Type A) means Kart 2 leaves the marked corridor during launch phase with at least two tyres before the start has been released. Leaving = the tyres are completely on or outside the corridor line.</p>		<p>General</p>
<p>39.18. FALSE START (Type B) means Kart 2 leaves the marked corridor during launch phase with at least four tyres before the start has been released. Leaving = the tyres are completely on or outside the corridor line.</p>		<p>A: 3 (three) seconds B: 5 (five) seconds</p>
<p>39.19 JUMP START means that Kart 2 accelerates during launch phase leaving Kart 1 behind before start has been released. It is irrelevant if the start will be repeated afterwards.</p> <p>39.20 JUMP START means that Kart 1 accelerates during launch phase leaving Kart 2 behind before start has been released. It is irrelevant if the start will be repeated afterwards.</p>	 	<p>Without advantage</p>
<p>Not relevant</p>		<p>With advantage</p>
<p>General</p>	<p>10 (ten) seconds</p>	<p>Without advantage</p>
<p>Not relevant</p>	<p>With Advantage:</p>	<p>Not relevant</p>

39.21 CUT IN means that Kart 1 constricts the drivable section towards the curve centre forcing Kart 2 to leave the drivable section either partial or completely for passing the curve. It is irrelevant if the karts have touched each other or not. A prerequisite is; however, Kart 2 has to be at least 1/3 (front tyres next to rear tyres) next to Kart 1.

An advantage is at hand, if (either/or):

- Kart 2 suffers a position loss or drop – out
- Kart 2 suffers a damage leading in a position loss of drop-out in the same lap



General
Not relevant
Without advantage
10 (ten) seconds
With Advantage:
10(ten) positions

39.22 EDGED – INTO means that Kart 2 drives next to Kart 1 (e.g., in order to start an overtaking action) without possessing enough drivable section (including kerbs). It is irrelevant if Kart 2 is completely or partial off the track.

An advantage is at hand, if (either):

- Kart 2 wins a position
- Kart 1 suffers a position loss or drop – out
- Kart 1 suffers a damage leading in a position
- loss or drop - out in the same lap

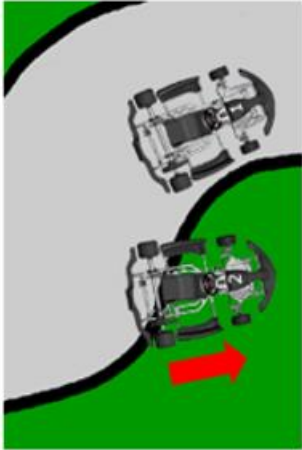
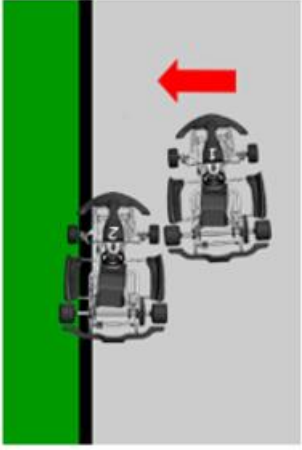

General
Not relevant
Without advantage
10 (ten) seconds
With Advantage:
10 (ten) positions

<p>39.23 SHORT – CUT means that Kart 2 leaves the track completely and returns to the track at a different section. It is irrelevant why Kart 2 has left the track.</p> <p>An advantage is at head, if (either/or):</p> <ul style="list-style-type: none"> -Kart 2 wins a position or gains time which cannot be balanced at the same lap -Kart 1 or any other is handicapped by the return of Kart 2 -Kart 1 or any other suffers a position loss or drop- out by the return of Kart 2 		<table border="1"> <tr><td>General</td></tr> <tr><td>Not relevant</td></tr> <tr><td>Without advantage</td></tr> <tr><td>Warning only</td></tr> <tr><td>With Advantage:</td></tr> <tr><td>10 (ten) positions</td></tr> </table>	General	Not relevant	Without advantage	Warning only	With Advantage:	10 (ten) positions
General								
Not relevant								
Without advantage								
Warning only								
With Advantage:								
10 (ten) positions								
<p>39.24 PUSH OUT means if Kart 1 constrict the drivable section towards the outside line forcing Kart 2 to leave the drivable section either partial or completely. It is irrelevant if the Karts have touched each other or not. A prerequisite is, however, that Kart 2 has to be at least 1/3 (front tyres next to rear tyres) next to Kart 1</p> <p>An advantage is at head, if (either/or):</p> <ul style="list-style-type: none"> - Kart 1 wins a position - Kart 2 suffers a position loss or drop – out - Kart 2 suffers a damage leading in a position loss or a drop - out 		<table border="1"> <tr><td>General</td></tr> <tr><td>Not relevant</td></tr> <tr><td>Without advantage</td></tr> <tr><td>10 (ten) Seconds</td></tr> <tr><td>With Advantage:</td></tr> <tr><td>10 (ten) positions</td></tr> </table>	General	Not relevant	Without advantage	10 (ten) Seconds	With Advantage:	10 (ten) positions
General								
Not relevant								
Without advantage								
10 (ten) Seconds								
With Advantage:								
10 (ten) positions								

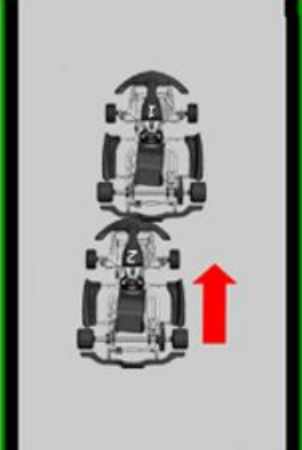
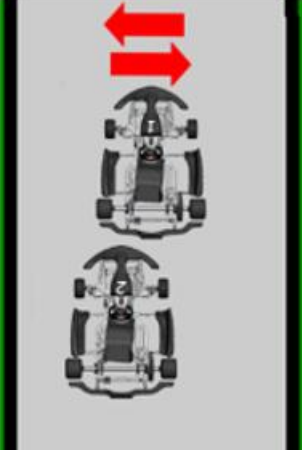
<p>39.25 BUMP means that the front of Kart 2 touches the rear of Kart 1. Neither the reason nor the intensity of the contact is relevant. Only the consequences of the impact are relevant to judge an advantage, not the impact itself.</p> <p>An advantage is at head, if (either/or):</p> <ul style="list-style-type: none"> - Kart 2 wins a position, and the previous order cannot be restored within the same lap - Kart 1 suffers a position loss or drop – out - Kart 1 suffers a damage leading in a position loss or a drop – out within the same lap 		<table border="1"> <tr><th>General</th></tr> <tr><td>Not relevant</td></tr> <tr><td>Without advantage</td></tr> <tr><td>Warning only</td></tr> <tr><td>With Advantage:</td></tr> <tr><td>10 (ten) positions</td></tr> </table>	General	Not relevant	Without advantage	Warning only	With Advantage:	10 (ten) positions
General								
Not relevant								
Without advantage								
Warning only								
With Advantage:								
10 (ten) positions								
<p>39.26 ZIG – ZAG means that Kart 1 changes the driving line more than two times on a straight track section for more than a kart width. It is irrelevant how far Kart 1 is ahead of Kart 2 or if Kart 2 would have been able to overtake.</p> <p>An advantage is at head, if (either/or):</p> <ul style="list-style-type: none"> - Kart 1 acts more than once a time this way within the same race 		<table border="1"> <tr><th>General</th></tr> <tr><td>Not relevant</td></tr> <tr><td>Without advantage</td></tr> <tr><td>Warning only</td></tr> <tr><td>With Advantage:</td></tr> <tr><td>10 (ten) positions</td></tr> </table>	General	Not relevant	Without advantage	Warning only	With Advantage:	10 (ten) positions
General								
Not relevant								
Without advantage								
Warning only								
With Advantage:								
10 (ten) positions								

40. LICENSE PENALTY SYSTEM (LPS)

As in F1 or daily life, there need to be consequences for our actions and so when you enter the SA Rotax Max Challenge and any associated karting event you choose to follow and abide by the regulations including the LPS.

The **LPS** is not intended to remove rights but rather to make everyone more conscious of when their actions impact the rights of others involved in our sport and create an unpleasant environment.

It needs to be understood that team members, parents and or guardians’ misconduct will lead to license penalty points for competitors.

The Code of Conduct LPS system:

1. All competitors will start with twelve (12) points
2. A rolling twelve (12) month total for all competitors will be kept by RMC.
3. An immediate (three) 3-month racing ban will be applied to all competitors reaching zero points. MSA will notify the competitor of their ban when their points have reached zero.

- a. Only months where at least one (1) MSA National, Regional Race or the Africa Open in the competitors' own region will be counted, i.e., December and January will not count as one (1) of the three months.
 - b. After a competitor has served a ban as identified in point 3, his/her points will be reset to twelve (12) points.
4. The Clerk of the Course and the Stewards at a Regional, National race day or the Africa Open are empowered to deduct penalty points, following an appropriate hearing as per GCR 175, according to the scale below:
- a. Additional penalty points (up to a maximum of (four) 4) - over and above any penalty - may be deducted for any offence not listed herein at the sole discretion of the Clerk of the Course or the Stewards.
 - b. The Licence Penalty System applies to National, Regional and Africa Open events.
 - c. Six (6) points will be deducted for physically or verbally abusing an official.
 - d. Six (6) points will be deducted for accusations of bias that cannot be substantiated.
 - e. Six (6) points will be deducted for any abusive comments on social media (Facebook, Twitter, etc.) between teams, competitors, officials and organizers.
 - f. Any driving conduct or sporting incident that is considered serious enough by the Clerk of the Course or the Stewards (in the case of a protest) to warrant an LPS penalty will incur:
 - i. A two (2) point deduction at a Regional and the Africa Open after the hearing with the competitor concerned.
 - ii. A 4 (four) point deduction at a National after the hearing with the competitor concerned.
 - g. 6 (six) Points will be deducted for public misbehavior/poor conduct - causing any disturbance or public spectacle unbecoming of a sporting event. Retaliation is seen in the same light as aggression and will not be accepted as an excuse or a defense in a plea for mitigation.
 - h. Prize giving is part of race day and foster sportsmanship. Penalty points will be applicable if podium finishers miss prizegiving without notifying the Secretary of the meeting before the prizegiving:
 - i. 1 (one) point will be deducted
 - ii. Not wearing a race suit properly zipped up for interviews, photographs or podium presentations will be deducted for the first offence,

41. FLAGS

- 41.1 The extinguishing of the red lights 4 (four) to 7 (seven) seconds after being lit will indicate the start of the race. Alternately it is permitted to start by raising the MSA flag above the head and lowering it, this will indicate the signal to start.
- 41.2 Yellow flag with green diagonal cross/crosses – indicates that the race has false started and that the field must slow down and reform the starting grid.
- 41.3 Finish Flag – a black and white checked flag.
- 41.4 Red Flag – The practice/qualifying/race has been stopped. Competitors must immediately slow down, being prepared to stop if so indicated and return at a very reduced speed to the start line and await further instructions.
- 41.5 Black Flag – Always shown with the competitor's number, the competitor must stop at the pits at the end of the lap and report immediately to the Clerk of the Course.
- 41.6 Black & White Diagonal flag – Always shown with the competitor's number, the competitor is observed for unsporting behaviour and must stop such behaviour immediately and report to the Clerk of the Course immediately after the practice/qualifying/race.
- 41.7 Black flag with orange disc – Always shown with the competitor's number. The competitor is warned that his/her kart has a potentially dangerous technical defect and must stop in the pits at the end of the lap

to remedy same. Having crossed the scale and repaired the defect a competitor may re-join the practice/qualifying/race.

- 41.8 Yellow flag - indicates potential danger or obstruction on the circuit – no overtaking until one has passed the incident. Overtaking under yellow flag will result in a penalty.
- 41.9 The use of a green flag must be stated in the SR's for an event where the officials deem necessary to indicate that the circuit is clear (after a yellow flag). No overtaking allowed before the green flag.
- 41.10 Yellow and red striped flag – change of surface e.g., fluid/sand on the track.
- 41.11 White flag – there is a slow-moving vehicle on the circuit. This could be a slow kart, an ambulance or service vehicle.
- 41.12 Blue Flag – Indicates to a competitor that a faster competitor is about to overtake. Only shown to a competitor being lapped.
- 41.13 Blue Flag with red diagonal crosses – always shown with a number board, indicates to a competitor that he is lapping too slowly and that he must leave the circuit at the end of that lap.

----- END OF SPORTING REGULATIONS -----