

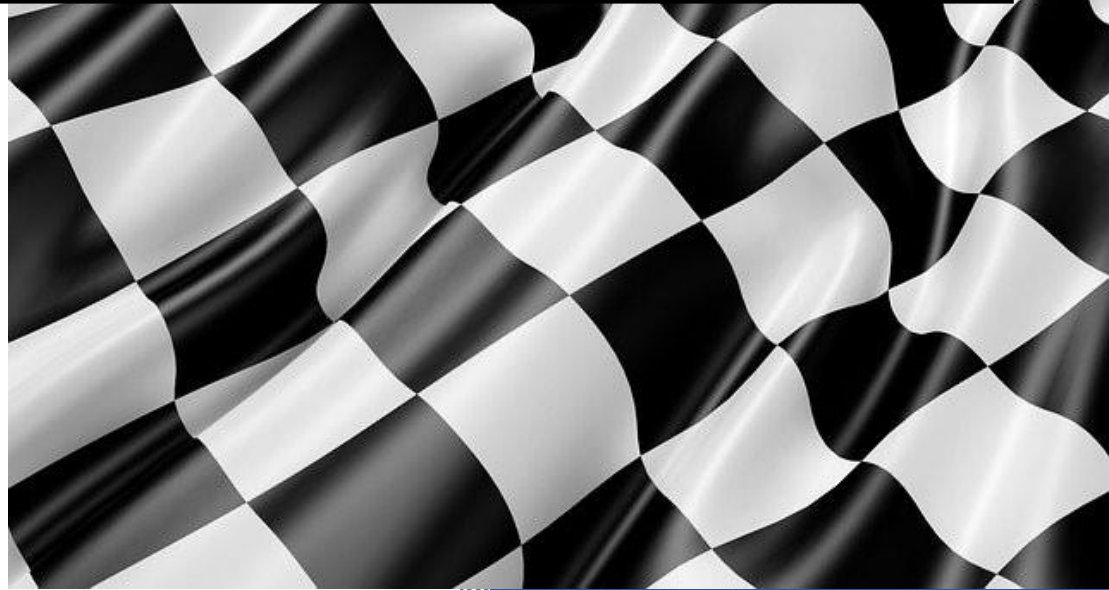

2024

## Club Standing Supplementary Regulations

### Inex Legends Championship



Version 1

1 January 2024

163205

## REVIEW AND AMENDMENTS

Motorsport South Africa (MSA) will periodically review these rules and will present the revised version to all members for agreement to publish the updated version.

Amendments and updates to the rules will be recorded in the Amendment Record, detailing the updated version, date of approval of the amendment and a short summary of the amendment.

## AMENDMENT RECORD

<i>Modified SSR / Art</i>	<i>Date Applicable</i>	<i>Date of Publication</i>	<i>Clarifications</i>

### **A1 INEX SA AFFILIATION AND MEMBERSHIP:**

Application forms INEX LEGENDS SA affiliation can be obtained from the INEX LEGENDS SA office which is solely responsible for issuing and processing of the memberships. Membership application forms must be fully executed, signed by the applicant, and accompanied by the appropriated funds. The mere acceptance of an INEX affiliation membership application form in the field or at INEX SA does not constitute the issuance by INEX SA of INEX SA membership. INEX SA may deny membership or cancel membership to any applicant or member. Applicant or members will be advised in writing by INEX SA if their membership has been cancelled or denied. INEX SA affiliation membership are on a one year basis beginning January 1<sup>st</sup> to December 31<sup>st</sup> of that year unless otherwise noted. Members are urged to pay their membership fees by the latest January of each year. INEX Legends U.S. membership fees must be paid as INEX Legends SA is an extension of INEX in the United States. INEX LEGENDS SA membership fees must be paid for a driver to participate in a ILSA sanctioned event. All drivers must be in possession of a MSA license. At some events competitors/entrants will be liable for the INEX technical inspectors fee in cash before a race meeting. Such amount will be communicated to participants in advance. Technical controller, race organizers, clerk of the course, racetracks and/or promoters can prohibit participation by any competitor at their discretion. All competitors must have submitted their entries/applications to the event organizers and INEX SA before a racing event to compete in such sanctioned event. To receive points a competitor must have a valid INEX SA affiliation membership card or member number.

### **B1 WORKING REGULATIONS:**

These regulations are drafted by INEX LEGENDS CARS SOUTHERN AFRICA (hereafter known as ILSA) in conjunction with the official US LEGENDS CARS INTERNATIONAL (hereafter known as USLCI) Rules. INEX RACING CORPORATION SOUTHERN AFRICA LIMITED (hereafter known as IRCSA) is the sole importer, seller, sanctioning, and scrutineering body as authorized by USLCI.

### **C1 ELIGIBILITY**

Cars must comply with USLCI manufacture rules. Only Legends cars as supplied and authorized through a registered authorized dealer (IRCSA) in Southern Africa will be eligible for participation. Any Legend car partaking in any social or racing event south of the Equator in Africa must be sanctioned by IRCSA/ILSA. All spare parts and service parts must be procured through a registered authorized dealer (IRCSA) in

Southern Africa. No internationally purchased parts are allowed, and no hybrid parts are allowed. The re-manufacturing or copying of Legend car parts is not permitted. The responsibility to prove eligibility is always that of the entrant. All drivers are responsible for their own submission of documentation and will comply with the governing body requirements regarding licenses and the submission of post-race reports i.e.: incident reports etc. as required.

## **D1 CATEGORIES**

### **PRO, MASTERS, SEMI-PRO, YOUNG LIONS, OVER ALL WINNER**

- **YOUNG LIONS:** Drivers 14 - 15 years old as of January 1, of the current year. 12 and 13-year-old drivers with previous racing experience may be included in this class at the Series Promoter's discretion. Drivers may stay in this for only 2 years and then move to SEMI-PRO with approval ILSA. If a driver turns 16 during this 2024 calendar year, that driver will have the option to move up to SEMI-PRO on his/her birthday. This requires a written request from the driver to ILSA. National/Regional/Club points will not be transferred from one division to another. IRCSA/ILSA has no authority in this matter. All competitors (or their parents in the case of minors) must sign a document confirming they are agreement with the 'Young Lions' class being incorporated into regular Legends races. Competitors in the 'Young Lions' class must start behind the main grid, regardless of their qualifying times.

**Any young lion driver must be cleared by INEXSA before any racing will be allowed as follows:**

- **Track session which must be attended by INEXSA Committee appointed members with race experience.**
- **Young Lion will be evaluated to determine car control and lap pace. (SSR27 rule below)**

**INEXSA Committee appointed member will approve or decline Young Lion application in writing stipulating detail outcome of evaluation to allow racing with INEX SA**

The 110% qualifying time cut-off as per SSR 27 must be strictly applied at all times.

The COC shall, at all times, have the right to black flag a 'Young Lions' competitor deemed to be posing a danger to himself/herself, or other competitors.

This allowance, for the 'Young Lions' class to run in conjunction with regular INEX Legends races in their own category.

All Young Lions will carry the "rookie X" on the back of their cars.

- **SEMI-PRO: Drivers 16 years old and older:** Designed for drivers who are starting out in Legend racing only. No prior experience is necessary but beginners may be required to compete in consolation, B Mains, and/ or start in the rear of the field. The decision to put a driver to the rear will be at the discretion of the ILSA Committee.
- **PRO (Expert Class):** Designed for experienced drivers. Driver must have competed in some other form of professional motorsports or have competed in the "Semi- Pro," or "Young Lions" division in the Legend Cars Series in order to race in this division. This is the pinnacle class of Legend Cars racing and will be treated as such. Approval to compete in this class will be the decision of the ILSA Committee.
- **MASTERS:** The Masters division will feature drivers 40 years old and over as of January 1, 2024. If a driver turns 40 during the 2024 calendar year, that driver will have the option to move up to masters on his/her birthday. This move is not automatic, and a written request is required from the racer to INEX. National/Regional/Club points will not transfer from semi-pro or pro to masters. "Golden Masters" drivers are those over 50 and will be included as Masters. The top Golden Master driver will receive an additional award at certain events. Also, INEX will recognize a Golden Master champion at the end of the season for Asphalt, Road course, and Dirt Points.

- **OVERALL WINNER.** The overall winner will be determined by allocating points to the actual finishing position of the respective driver at the end of each race irrespective of the category finishing position. The same scoring methodology will be used that is used to score the categories. (See Par L1 for detail points)

1. Any points accumulated during the season will not be transferred if a driver changes divisions during the season.
2. Any driver desiring to change divisions must first receive approval from INEX in writing. Drivers wishing to move down in status must show proof that they are not properly classified. INEX reserves the right to place any driver into a different division (up or down) at its own discretion at any time. A driver cannot change division at the track the same day of a race and cannot change points and/or classification prior to official division change by INEX headquarters.
3. Running separated divisions in separate races will be at the Promoter's discretion depending on the car count at that speedway and the time schedule. A driver may only compete in one division if the event offers separate divisions (Pro, Masters, Semi-Pro) or any combination thereof.

#### **E1 LEGENDS CAR SPECIFICATON RULES**

ILSA have a compulsory technical inspection day at the beginning of each new racing season at the premises of ILSA. ILSA will advise members/owners of INEX LEGENDS CARS of the specific day that the inspection will take place. The following is expected of Members/Owners on the day of the inspection:

1. Completed Car to be race ready on the day of the technical inspection.
2. An Inspection will be done by ILSA Technical Team to ensure that the car to be entered for the season is fully compliant as per the ILSA Rules.
3. No Driver will be allowed to participate in any race for the Season if the car was not signed off by the ILSA Technical Team.
4. Inspection arranges to be done on another day then the specified inspection can be done by approval by the ILSA Technical Team at a rate determined by the ILSA Team on the day of the arrangement.

Upon entering a Legends Car for competition any car must be checked for engine, chassis, oil, fuel, tyres, wheels, rear ends or sound legality at any time by an ILSA official or representative. Upon entering a Legends Car for ILSA -sanctioned competition, the driver (and possibly the owner) is responsible for the legality of their car and will suffer all penalties resulting with the Legends Car violating these rules. Refusal to submit a car, engine or parts for inspection or measurement upon the request of an ILSA tech inspector will result in an immediate disqualification and may lead to a suspension for car owner, car and driver.

If this rulebook does not specifically say that you can change/modify/add/remove something, then you must consider that the change/modification/addition/removal is illegal. Any questions about the legality of a change/modification/addition/removal not covered in this rulebook, must be answered by ILSA in writing and presented to the tech inspector upon request. If you have a request for a change/modification/addition/removal, please contact ILSA before making the change/modification/addition/removal.

ILSA have Original INEX Legends parts that will be used as an Index to compare against parts installed in cars ensuring that those parts are Original INEX Legends Parts. Cars with parts that do not conform with the Index Part will be excluded from the race and the Non INEX Legends Part must be removed from that car. No equipment or race car will be considered as having been approved by reason of having passed through inspection "unobserved." Regardless of a Legends Car passing prior inspections, compliance with all rules

must be made at each post-race inspection. No expressed or implied warranty of safety shall result from the technical inspection or approval.

Enforcement of Specification Rules: All IRCSA/ILSA -approved weighing, measuring and testing devices used by the IRCSA/ILSA tech officials are the standards, which will determine compliance with the rules and regulations. A competitor's equipment, gauge or instrument, unless approved by the IRCSA/ILSA inspector will have no bearing on the enforcement of these rules. Car must start in tech area to perform inspections that require the car to start.

**Engine Builders:** INEX SA have only 2 x approved engine builders for year 2024. They are **Seef Fourie Racing** and **Big Boss Auto**. Any other Engine builder may apply to the INXE LEGENDS SA committee for approval. There are specific criteria that needs to be met in order to be an approved Engine Builder for INEX LEGENDS SA.

## **F1 SAFETY EQUIPMENT**

No express or implied warranty of safety shall result from publication of, or compliance with these rules and regulations. They are intended as a guide for the conduct of the sport and are in no way a guarantee against injury or death to participants, spectators or others. Whenever there is a conflict between a safety provision provided herein and any other rule, the safety provision shall take precedence.

1. **HELMET:** INEX requires that all drivers must wear a racing type helmet of current standards of 2000 Snell "SA" rating or later any time he/she is on the track for slow laps, practice or racing conditions. Snell "M" rated helmets will not be allowed. IRCSA/ILSA requires that all drivers must wear a racing type helmet of current standards of FIA rating any time he/she is on the track for slow laps, practice or racing conditions. Snell "M" rated helmets will not be allowed.
2. Drivers without a helmet meeting the above minimum Snell standards will not be permitted on the racetrack in a Legends Car. A helmet is designed to absorb energy once. If a significant impact has occurred to the helmet, it is highly recommended that it be sent back to the manufacturer for evaluation. Helmets are subject to inspection at each event by the technical inspector or other official. A full-face helmet is highly recommended.  
Helmets with Radio Harnesses - Many IRCSA/ILSA drivers compete in other racing series' that permit the use of radios. If a driver should use that helmet to compete in an IRCSA/ILSA-sanctioned event, he/she must duct tape the connector end to the back of their helmet. This is the only way in which this helmet will be permitted without actually removing the entire radio harness from the helmet. Radio wiring harnesses are not allowed in any Legends Car. Receivers will be used only at tracks that mandate them and must be tuned to the designated track frequency.
3. **FIRE RETARDANT GLOVES:** Fire retardant gloves are mandatory. Gloves must have "SFI" tag or wording included on care label stating that they are flame retardant.
4. **FIRE SUITS:** All drivers must wear a fire retardant suit of Nomex or equivalent material any time they are on the track. A double layer or more is highly recommended. Fire-suits must be labelled flame retardant (made of flame retardant materials or have a S.F.I. patch indicating fire retardant). Damaged suits may be disallowed by the inspector.
5. **SAFETY HARNESS:** All cars must have an IRCSA/ILSA/local controlling body-approved type of four, five or six-point racing harness that is equipped with a quick release buckle. Be sure to regularly check your safety belts for damage such as fraying, tearing, etc. If this should occur, the safety belts should be replaced immediately. An IRCSA/ILSA inspector may require replacement of the belts if they are damaged. ILSA endorses (not requires) the belt manufacturer's recommendation that the belts be changed two years after

the date stamped on the SFI tag regardless of the number of times the car has been raced. The safety belts are similar to a helmet, in that they are designed for protection in only one major impact. If you have had a significant incident, the manufacturer strongly recommends immediate replacement of the belts. Also, make absolutely sure that your safety harness is totally secured and that you have pulled the straps as tight as possible anytime you drive the car.

6. RACING SHOES: Drivers must wear automotive racing shoes.
7. ROLL BAR PADDING: Roll bar padding (SFI-45.1) on all bars within one foot (25cm) of the driver's helmet is MANDATORY.
8. FIRE EXTINGUISHERS: An on-board fire extinguisher is mandatory for your safety. All fire systems must be operational.
9. SEATS: Only IRCSA/ILSA or FIA-approved factory-manufactured seats may be used. No homemade seats will be permitted. Lightening the seat by anyone else other than the factory is not permitted. Mounting of the Seat in a Legends Car - The seat may be moved within the driver's compartment without moving or changing existing bars in the frame. The center line of the seat must be 10" (25.40cm) from the left side of the driver's compartment roll cage. The seat may be mounted directly to the floor-pan. When mounting the seat forward, use a flat piece of steel or aluminium behind the seat (don't just use bolts in tubing). The use of wood as supports or mounting brackets is not permitted. The presiding tech inspector shall have final approval of the mounting of the seat. Carriage bolts are not allowed for seat mounting. Hardware used to mount seat must be a minimum of grade 5 bolts.
10. FACTORY MANUFACTURED AUTOMOTIVE RACING HEAD AND NECK RESTRAINT SYSTEMS ARE MANDATORY FOR ALL DRIVERS.
11. OTHER SUGGESTED SAFETY EQUIPMENT: These items are not required, but they are all highly recommended. (An individual track or promoter may require some of these items).
  - Flame retardant underwear and socks.
  - Head sock (balaclava)
  - Steering wheel pad and knee pads.
  - Arm restraints and helmet supports on the seat.
  - Interior door pads and tunnel pad.

## **G1 FRAMES, BODY, SUSPENSION, etc.:**

**Only INEX approved air directional aids are permitted solely for engine and oil cooling purposes.**

1. AERODYNAMICS: Spoilers, air dams or other aerodynamic devices are not permitted.
2. AIR FILTERS: Only IRCSA/ILSA -approved K & N and stock air filters and Outer Wears Pre-Filters coverings are permitted. Velocity/ram stacks are not permitted. No components that direct airflow to the carburetors or increase airflow are permitted.
3. ALTERNATORS: Modification to the charging system is not permitted. The alternator must be charging at all times. No switches disconnecting the alternator are permitted. The engine must continue to run at an idle with the battery disconnected.
4. BALL JOINTS: The upper and lower ball joints must remain stock, within the stock dimensions, steel thickness, location and configurations as currently delivered by U.S. Legend Cars International and may not

be reinforced in any way. One or two (minimum 1/4" (6.05mm), maximum 7/16" (11mm) width) jam nuts are permitted on the upper and lower ball joints. Each ball joint must use at least one jam nut. The jam nuts may not be welded to the control arms.

5. **BALLAST:** A maximum of eight (8) blocks of lead are permitted. The blocks may be no larger than 1- 1/2" x 2-1/2" x 12" (40mm x 60mm x 300mm) and the stacking of blocks is illegal. Two blocks of lead of any size may not be in contact with each other. All lead must be clearly visible with white or neon paint/tape and marked with the car number. Ballast must be lead only and may not be added by any other method, including steel shot or any other material in the frame rails, bumpers, nerf bars or any other component.
  - 5.1 **Mounting Ballast** - The blocks must be bolted directly to the frame and must be secured with a minimum of two (2) 3/8" (10mm) bolts. Lead may be bolted to the square tubing of the sub-frame (1" X 2" (25mm x 50mm) tubing only), not the roll cage. The blocks may not be encased in any way. There must be a minimum of 3 1/2" (80mm) of clearance between all lead weights and the ground. Ballast may not extend past the frame horns in the front or rear or extend beyond the corners of the sub-frame at the kick ups. Ballast may not be placed anywhere inside the driver's compartment. No ballast may be bolted to the running board or its mounting brackets. Ballast may not extend beyond 2 1/2" (63.5 mm) from the side of the frame. All mounting of the ballast is subject to final approval by the ILSA technical inspector.
6. **BATTERY:** Only a lead acid or gel cell battery (25lbs. (11kgs) min.) may be used. The approximate dimensions are 71/8" X 8 X 61/2" (80mm x 203mm x 65mm). A top post or side post battery may be used. Motorcycle batteries may not be used. The battery must remain in its stock location and securely mounted. The original stock battery bracket may not be altered or repositioned in any way. A battery box, terminal coverings or rubber padding around rear end is also highly recommended. A battery shut-off switch is mandatory.
7. **BOLTS AND FASTENERS:** Only equivalent stock or upgraded steel fasteners and bolts may be used on the Legends Car. Fasteners may be drilled for safety wire but intentional weight-saving modifications are not permitted. All bolts must be magnetic, aluminum and titanium bolts are illegal.
8. **BRAKES:** Any of the brake parts that are attached to the rear end or the spindles must remain stock, within the stock dimensions, steel thickness, location and configurations as currently delivered by U.S. Legend Cars International. The car must have operational brakes on all four wheels and must lock up all four wheels during inspections (Brake lines may not be plugged or completely shut off). Any type of cooling duct to the brakes is prohibited. The right or left side brake pedal may be removed.
  - 8.1 **Brake Rotors** - Only steel rotors (not drilled or reduced in diameter) are permitted on the front. The minimum permitted thickness of the brake rotor is 8mm wide.
  - 8.2 **Brake Drums** - Only steel drums (not drilled or lightened) are permitted on the rear. The minimum weight of the brake drum is 10.0 lb. (4.5kgs). Intentional metal removal of the brake drum for lightening purposes is considered illegal. Only the "shoe face" may be machined.
  - 8.3 **Brake & Clutch Lines** - Rubber, hard-line or steel-braided brake and clutch lines are permitted. No brake lines may be disconnected or plugged at any time for competition.
  - 8.4 **Brake Master Cylinder** - The brake master cylinder must remain stock, within the stock dimensions, location and configurations as currently delivered by U.S. Legend Cars International. The brake master cylinder must remain on the engine side of the firewall. No aftermarket brake master cylinders are permitted. Aftermarket remote reservoirs are permitted.
  - 8.5 **Brake Proportion Valves** - Only one brake valve or residual valve or pressure valve will be allowed. One unit per complete brake system. Complete elimination of the brake at any wheel is prohibited.
9. **BUMP STEER:** Adjustments to bump steer settings will only be permitted by placing spacers between the

steering rack and the heim ends of the tie rods or between the front spindle pickup points and the heim ends of the tie rods. No other modifications to adjust bump steer such as changing the height of the steering rack or modifying the spindles are permitted.

10. **BUMPERS:**

10.1 Front Bumper - The front bumper must remain within the stock dimensions, steel thickness, location and configurations as currently delivered by U.S. Legend Cars International and may not be reinforced in any way, except for adding one (1) additional bolt per front and/or rear frame rail to the tab.

10.2 Rear Bumper - The rear bumper must remain within the stock dimensions, steel thickness, location and configurations as currently delivered by U.S. Legend Cars International. The rear bumper may be reinforced by attaching tubular steel from the bumper to the rear frame horns. Adding one (1) additional bolt per frame rail to the tab is permitted. If reinforced, the steel tubing may not extend beyond the outside width of the rear fenders or attach to the rear cross-member of the frame and may be no longer than twelve (12") (30.5cm) inches.

10.3 Attachment of the Bumper – Bumper tabs must use a minimum of one bolt per tab securing the bumper. There must be a minimum of 1" (25mm) from the end of the frame rail to the back of the bumper upright before a race begins. Should the tab become bent during a race, it must be fixed before the next time the car goes on the track to compete or practice. Tie-wraps, safety wire, duct tape, etc., are not permitted to secure the front or rear bumpers or bumper tabs at anytime.

10.4 Bumper Tabs - The bumper tabs must be stock as delivered by U.S. Legend Cars International and may not exceed 1/8" (.125") (3mm) in thickness. Tabs stamped "INEX" as delivered by U.S. Legend Cars International will be .140" (3.5mm) thick. Tabs with excessive weld may be considered illegal.

10.5 Repairing a Bumper During a Race: Bumpers must be bolted on. Tie-wraps, safety wire, duct tape, etc., are not permitted to repair the front or rear bumpers at any time. An IRCSA/ILSA technical inspector will disqualify a driver after a race if the repaired bumper violates this rule.

11. **CARBURETORS:** The carburetors and components of the carburetors must remain as stock Yamaha FJ1200/XJ1200/XJR1250 (sealed) as currently delivered by U.S. Legend Cars International. Only carburetor jets(not less than 1.20mm), needles, slide springs and butterfly screws may be changed. (butterfly screws may only be replaced with 3m. X 6m. allen head screws or stock screws. These screws may not be altered in any way other than "stamping" the end to secure the screw.). No other modifications to the carburetors or components of the carburetors are permitted.

Modifications or components to increase or restrict airflow or fuel flow (such as velocity stacks, heat deflector shields, internal modifications not listed above, etc.) are not permitted.

12. **CHROME PLATING/POLISHING:** External parts such as bumpers, nerf bars, suspension components and cam cover may be chrome plated or polished.

13. **CLUTCH MASTER CYLINDER:** The clutch master cylinder must remain stock, within the stock dimensions, location and configurations as currently delivered by U.S. Legend Cars International. The clutch master cylinder and reservoir must remain on the engine side of the firewall. No aftermarket clutch master cylinders are permitted. The clutch pedal may be shortened for driver comfort.

14. **CONTINGENCY SPONSOR DECALS:** The display of Series sponsor and official Legends SA decals are mandatory, however contingency decals are mandatory and /or use of the product to be eligible for posted awards sponsored by the contingency sponsor.

15. **DOOR PLATES:** Doorplates on driver's side door are mandatory. Doorplates and strike plates must meet current factory specifications. These door plates are permitted to be added to the right side door. A competitor may use a door plate covering the entire door area on either side of the car as long as it is a



maximum of 3.5mm thick, and the left side percentage of weight remains less than 52%.

16. DRIVESHAFT: The driveshaft, flanges, and u-joints must remain within the stock dimensions, steel thickness, location and configurations as currently delivered by U.S. Legend Cars International. Lightening the driveshaft in any way is illegal. Driveshaft must be painted white or light grey.
  - 16.1 Driveshaft retainers - An INEX-approved driveshaft retainer strap is permitted. A maximum of three (3) retainers of 1/4" (6mm) thickness and 3/4" (19mm) width are permitted. Requests for additional retainers for the driveshaft must be sent to and approved in writing by IRCSA/ILSA.
17. ENGINE COATINGS: Only coatings as delivered stock from the factory are permitted throughout the engine. Intentional removal of any coatings is not permitted. Headers may be painted with high heat paint only. (Header wrap tape is ok.) Repainting the outside of the engine or using an unpainted engine is permitted.
18. ENGINE COOLING: Extra fans, internal duct work, hood louvers, remote oil filter, header wrap, holes in the hood, holes in the front fenders and/or oil coolers are permitted. The maximum height for louvers is 3/8" (10mm). The size of the area for louvers or holes in the hood may not exceed 120 square cm (15cm x 8cm). These components may not direct air to the carburetors or air filters in any way.
19. ENGINE SERIAL NUMBERS: All engine casings must have a serial number. Any engine casing without a serial number will not be permitted to be used in any IRCSA/ILSA-sanctioned events.
20. ENGINE LOCATION & MOUNTS: Left and right side engine mounts must remain within the stock dimensions, steel thickness (no aluminum mounts), location and configurations as currently delivered by U.S. Legend Cars International. The right side motor mount may be replaced with the optional motor mount as delivered by U.S. Legend Cars International. (if the optional right side mount is used, you may remove the stock right side mounting tabs). The engine mounts must be bolted on to the frame as specified by U.S. Legend Cars International. Mounts may not be welded directly to the frame.
21. EXHAUST SYSTEM: The header, muffler and gasket must remain within the stock dimensions, steel thickness, location and configurations of the original, as currently delivered by U.S. Legend Cars International. The internal components of the header and muffler may not be altered. Stock U.S. Legend Cars International Borla (approved by IRCSA/ILSA as delivered by U.S. Legend Cars International, Inc.) are mandatory. Header wrapping (tape) is acceptable. Ceramic coatings are not permitted.
22. FENDER MOUNTING: Stock fender mounts may not be altered. No additional fender supports or mounts are permitted (only stock mounts may be used). All '37 Ford style grills must use the inner mounting hole (closest to the grill). Dzus buttons may be used for fender removal purposes.
  - 22.1 Area under the Rear Fenders - Removal of the fiberglass on the body half under the rear fenders is permitted for easier access to the shocks, springs and rear compartment as long as it is still in the spirit of the General Appearance.
23. FENDER HOLES and TRIMMING: The trimming and holes that are permitted are as follows:
  - 23.1 Holes - Four (4) round holes maximum per front fender ONLY. These holes may not be any larger than four (4) inches (100mm) in diameter maximum (Note: a four-inch hole saw will produce a hole larger than four inches/100mm). Any shaped hole equal to or less than the area of a 4" (100mm) round hole is acceptable.
  - 23.2 Trimming - The only trimming allowed on the inside edge of the fender will be for engine clearance (air breathers, header, etc.) this trimming must be done 16" (46mm) above the frame rail on the front clip along the contour of the fender, and may only be trimmed in 3" (76mm) from the edge. The inside of the fenders near the grill, the edge of the fenders near the body shell, and the bottom edge

of the front of the fender may not be trimmed.

23.3 Rear Fenders - Rear fenders may be trimmed above the tyre for additional clearance. The rear fender contour must measure at least ten (10) inches (205mm) from the main body shell. Measurements will be taken at the point on either rear fender above top dead center of the tyre. No holes are permitted in the rear fenders or body shell.

24. FIBERGLASS COMPONENTS: All fiberglass components must remain within the stock dimensions, thickness, location and configurations as currently delivered by U.S. Legend Cars International and may not be reinforced or intentionally lightened in any way. The use of a complete front end (Matching hood, fenders, grill and grill shell) on a different model car is acceptable. It must be complete with all listed components from the same model.

24.1 Mounting of Components - All fiberglass body components must be firmly attached to every Legends Car competing in any race. It is recommended that all dzus fasteners fit tight and are taped over to prevent loosening. Any Legends Car may be black flagged or denied entry to start a race if any of the aforementioned items are not attached unless prior approval is given by the IRCSA/ILSA technical inspector. Removal of undamaged fiberglass components (hood, deck lid, etc.) during an event is not allowed.

25. FIREWALL: A metal firewall is mandatory. Firewall must be installed as currently delivered by U.S. Legend Cars International. Using a "thicker than stock" metal firewall separating the driver's compartment from the engine compartment is OK.

26. FRAME: Absolutely no modifications of the frame (including roll cage) will be permitted unless otherwise noted in this rulebook. Any other requested chassis modifications or unusual repairs are only permitted with a letter from IRCSA/ILSA. All frames must have I.D. plate secured on the frame, inside left main frame rail.

26.1 Frame Update - As of January 1, 2000, all Legends Cars frames (coupes and sedans) with an 0.065" E.R.W. main roll cage will no longer be eligible for competition in the IRCSA/ILSA Series. All frames must be replaced with a 0.083" D.O.M. main roll cage frame. It is estimated that all frames produced before August, 1995 do not meet the above 0.083" D.O.M. Requirements.

26.2 Serial number plates - All cars & frames running as Inex Legends Cars must be produced by U.S. Legend Cars International. All cars must carry the serial number assigned to that frame. This plate shall not be tampered with in any way. For any reason, the car owner must also be able to produce the title for the car within 48 hours after a request by an ILSA technical official or that car will be ineligible for any competition.

26.3 Metal Fatigue - It is highly recommended to have the frame checked periodically by an expert for metal fatigue. Cracked or broken frames are strictly prohibited from any IRCSA/ILSA -sanctioned events.

26.4 Suicide Doors - Doors with the latch on the A-Pillar and hinges on the B-Pillar rather than the traditional method of the latch on the B-Pillar and the hinges on the A-Pillar. Suicide doors are only permitted on the 1934 Ford and Chevy Coupe frame.

27. FRAME REPLACEMENT: If the chassis should become severely damaged, replacement frames must be purchased through U.S. Legend Cars International via its authorized dealer in Southern Africa which is INEX RACING CORPORATION SOUTH AFRICA LIMITED.

28. FRAME REPAIR: Only front and rear clips may be replaced as long as they are replaced with a clip supplied by US Legends International and all pickup points must remain in the stock locations as delivered currently from U.S. Legend Cars International. The clips must be purchased through IRCSA/ILSA. The driver's compartment of the frame (roll bars, cross braces, etc.) may not be repaired or replaced if damaged (see

rule #27 above - Frame Replacement). The IRCSA/ILSA technical inspector reserves the right to disallow a repaired car from an IRCSA/ILSA-sanctioned competition that does not appear to be properly repaired. Once a frame is repaired from its original form, IRCSA/ILSA, U.S. Legend Cars International and the technical inspector assume no liability for any injuries that may occur as a result of this repair regardless of the approval given to compete with that repaired frame.

29. FUEL: Only petroleum-based unleaded 95 octane pump fuel is permitted. **No octane boosters or fuel additives are permitted.** ILSA reserves the right to inspect and replace a competitor's fuel if deemed necessary. A minimum of 1(one) liter of fuel must be present in the fuel tank after every race. Failure to extract a minimum of 1-liter post-race will result in a removal from results from that heat.

29.1 Laboratory Testing – IRCSA/ILSA has the ability to conduct laboratory analysis of fuels. Samples for lab analysis may be taken from a competitor's fuel tank at any time at the discretion of the IRCSA/ILSA Technical Inspector. INEX reserves the right to replace any competitors fuel prior to any heat/race at the Technical Consultants discretion. Replacement fuel must be done in the presence of the TC and the fuel cap will be sealed by the TC. IRCSA/ILSA will stipulate from which fuel outlet the replacement control fuel will be purchased.

The specific elements which will be searched for include: propylene oxide, alcohols (all types), aldehydes, amino diphenyl, benzene (in excess of EPA limit), benzidine, beryllium compounds, bromine compounds, butadiene, chlorinated compounds, chromates, dioxanes, ethyl acrylate, ethylene oxide, hydrazine compounds, methylene dianiline, naphthylamine, nitrogen compounds (nitromethane, et al.), styrene's, toluidine and xylidine.

29.2 Penalty for Fuel Rule Violations - Any competitor (driver and/or owner) caught using any of the illegal fuel additives as previously mentioned is subject to a minimum 60-day suspension from the date of the test results. Suspensions will be determined by ILSA based on the chemical composition of the additive in question.

29.3 FUEL CELL: IRCSA/ILSA -approved fuel cells (plastic or metal) must be stock as delivered by U.S. Legend Cars International. and must remain in the stock location. Metal fuel cells must be bolted through bolt holes in steel can. Foam is mandatory in all fuel cells as delivered by U.S. Legend Cars International (cars are not permitted on the track without foam in the fuel cell). The red plastic fuel cell with the 5 5/8" cap or larger is no longer allowed.

29.4 Fuel Cap - Make absolutely sure that you check the cap on your fuel cell for tightness before going onto the race track. The cap should fit snugly into the cell. The car number must appear on fuel cell cap.

29.5 Fuel Cooling Devices - Fuel cooling devices of any kind are not permitted on the car at any time.

29.6 FUEL FILTER: Aftermarket fuel filters may be used. No glass fuel filters will be permitted. **No plastic fuel filters are permitted in the engine compartment.**

29.7 FUEL LINES: **Fuel lines may not be located in or run through the driver's compartment of the frame. Steel braided fuel lines are mandatory. Fuel lines may not be attached to or come in contact with the electrical wires.**

29.8 FUEL SHUT-OFF VALVE or FUEL REGULATOR: Aftermarket fuel shut-off valves and fuel regulators are permitted.

30 GAUGES: Analog Gauges that record or display the following information only are permitted - cylinder head temperature, RPM, oil pressure and oil temperature. Digital gauges are not permitted with the exception of stock gear indicators, Longacre and Intercom lap timers, lap receivers (By RACE receivers), and Fastach

Digital Tach (By SenDec, Corp.) as delivered by U.S. Legend Cars International. No other information to include, but not limited to, wheel spin, shock travel, exhaust gas temperature, throttle position or G-force, will be allowed at any time. On-board telemetry systems are not permitted. Direct reading oil temperature and oil pressure gauges must use steel braided lines, not plastic or rubber.

31 GEAR RATIOS: Only a rear-end gear ratios of 2.93 is permitted. The gears must remain within the stock dimensions, steel thickness, location and configurations as currently delivered by U.S. Legend Cars International.

32 GENERAL APPEARANCE OF THE CAR: All competitors must present a neat, clean and stock appearing car for any IRCSA/ILSA -sanctioned competition. Crash damaged cars must be repaired to the minimum technical standards before returning to competition. An IRCSA/ILSA official may deny a car from competing if it does not meet the minimum acceptable standards as mentioned above. IRCSA/ILSA reserves the right to deny access in competition because of a sponsorship, advertisement, paint scheme and/or lettering on a car not in "good taste," or in the spirit of keeping this a family sport.

33 GRILL: The steel grill must remain within the stock dimensions, height, steel thickness, location and configurations as currently delivered by U.S. Legend Cars International and may not be reinforced in any way. The grill used must be the same model of the hood, grill shell & front fenders that are used. Only wire screens are permitted to enclose the grill area (i.e. for dirt tracks to keep out mud and dirt). Duct tape or any other type of material other than a wire screen is not permitted to enclose the grill area. Grill brackets (to the frame) must remain stock. Altering the brackets to raise or lower the grill is not permitted.

34 GUSSETS: Strengthening gussets may only be added in the spots as described in the APPENDIX. No stock gussets may be removed.

35 HEIM ENDS: Only magnetic steel helms as currently delivered by U.S. Legend Cars International or of very similar dimensions are permitted on a Legends Car. The stock helms are designed to bend/break and absorb energy under impact. Helms may be upgraded, however under impact, the upgraded helms may not bend or break as quickly thereby transferring the impact-energy to the driver and an injury may result (i.e. broken wrist from the transfer of energy). Aluminum helms are not permitted.

36 HOOD: Hood louvers are permitted maximum 3/8" (10mm) high. Replacing the dzus fasteners on the rear of the hood with hood pins is permitted. Raising the rear of the hood on these pins a MAXIMUM of 1/2" (12mm) is permitted. While the car is on the track the hood must be secure and may not move up or down on the pin. Air ducts may be used on the inside of the hood as long as the duct does not direct airflow onto the carburetors or air filters. Hood louvers may not direct air to the carburetors or air filters.

37 IGNITION SYSTEM: The complete ignition/engine control system must be the original OEM parts for the Yamaha FJ1200/XJR1200/XJR1250. Electronic throttle (traction) controls are not permitted. In- line fuses only are permitted (no fuse blocks are permitted). Ignition pickup coil wires must run directly to the ignition box and may not be taped or tie wrapped to other wires. No open wires or unused connectors allowed within reach of the driver.

37.1 Ignition Control Box - The stock FJ1200/XJR1200/XJR1250 ignition control box (black box) or the red ignition box (marked INEX-Approved and delivered by U.S. Legend Cars International) are the only boxes permitted to be used and they may not be altered or relocated in any way. Only one ignition box is permitted on a car (multiple boxes are illegal). The original stock FJ1200/XJR1200/XJR1250 rev limiting system must be in proper working condition and may not exceed 10,500 rpm.

37.2 Swapping of Ignition Control Boxes – IRCSA/ILSA reserves the right to provide a substitute ignition/engine control system to any competitor at random at any time. The IRCSA/ILSA-provided system will be exchanged for a competitor's system and must be used for that event. IRCSA/ILSA is

not responsible for any engine failure due to a provided ignition/engine control system.

- 37.3 Coils - Coil Wires and Spark Plug Boots - These components must be stock Yamaha FJ1200/XJR1200/XJR1250(sealed) parts or grey Dynatek coil wires or red Dynatek coils marked with the INEX logo as delivered by U.S. Legend Cars International. The spark plugs may be replaced with any aftermarket type with similar thread size. Resistors must remain in spark plug wire ends.
- 37.4 Coil Mount - The “stock” coil mount may not be modified in any way and may only be replaced with an IRCSA/ILSA-approved coil mount.
- 37.5 Ignition Rotors - The ignition rotor must be a stock Yamaha FJ1200/XJR1200/XJR1250 (sealed) part or the rotor delivered with the “IRCSA/ILSA approved” red ignition control box as currently delivered by U.S. Legend Cars International. No aftermarket electronic ignition advancers are permitted.
- 37.6 Ignition Plates - The ignition plate must be a stock Yamaha FJ1200/XJR1200/XJR 1250(sealed) part or the plate delivered with the “INEX approved” red ignition control box as currently delivered by U.S. Legend Cars International. It may be slotted to advance the ignition timing of the engine. The ignition pickup cover is not mandatory.
- 38 JAM NUTS: At least one jam nut is required to be used with all radius rods and ball joints. One or two (minimum 1/4” (6mm) maximum 7/16” (11mm)) jam nuts are permitted on the upper and lower ball joints.
- 39 LOWER CONTROL ARMS: The lower control arms MUST remain stock, within the stock dimensions (12.5” x 16.25”) (31.75 x 41.28cm), steel thickness, location, and configurations as currently delivered by U.S. Legend Cars International and may not be altered in any way. Each measurement will have a tolerance of +/- 1/8” (0.125”) (3mm).
- 40 MANDATORY SERIES SPONSOR DECALS and PATCHES: IRCSA/ILSA and the Legends Cars decals must be prominently displayed in the IRCSA/ILSA -approved location at all IRCSA/ILSA -sanctioned events. The IRCSA/ILSA patch and mandatory sponsor patches must be displayed prominently on the right side chest area of the driver’s suit. Driver’s not displaying the proper decals and uniform patches will not be eligible for certain awards, prizes, etc. including those offered at year-end and may be prevented from competing at certain events.
- 41 MIRRORS: Cars may have a mirror for rear vision mounted within the driver’s compartment or outside the doors. The type of mirror(s) shall be the choice of each individual driver. Rear view mirrors on both sides and/or one dome mirror in the vehicle are mandatory.
- 42 MUFFLERS: IRCSA/ILSA -approved U.S. Legend Cars International stock Borla mufflers are MANDATORY. Mufflers must remain stock and may not be internally modified in any way (turning tip away from car is permitted).
- 43 NERF BARS: The nerf bars must remain within the stock dimensions, steel thickness, location and configurations as currently delivered by U.S. Legend Cars International and may not be reinforced in any way. No other type of nerf bars are permitted. Nerf bars may not be used to hold ballast.
- 44 NUMBERS: The car must have numbers that are a minimum height of 21cm per digit on both front quarter panels in front of the door. The car number (minimum 18cm high) must be on the right front fender. The size, colour and style of numbers must be adequate to permit prompt identification by track officials at all times.
- 45 OIL ADDITIVES: Any competitor caught using any of the following additives in the engine oil may be banned from all ILSA -sanctioned events: hydrazine, toluene, dinitrotoluene, dioxane, propylene oxide, nitropropane or any additives determined by IRCSA/ILSA to be hazardous.

- 46 OIL CATCH CANS: An oil catch can (maximum 1-quart capacity) (750mm) may be used. It must be securely fastened and remain within the engine compartment. It may only be routed to by a hose from the stock crankcase breather opening and/or the oil fill cap.
- 47 OIL COOLERS & LINES: Oil coolers must be cooled by air only (no dry ice systems or other type). All oil cooling systems (including lines) must be mounted in the engine compartment only. No oil coolers or lines may be mounted in the drivers' compartment or in the rear deck. More than one oil cooler is permitted. Oil cooler fans are permitted. Push-lock fittings are permitted. Oil coolers may not be mounted below the bottom of the front bumper. Aftermarket oil coolers are permitted.
- 47.1 Oil Cooler Scoops - Oil cooler air scoops (with a max. wall thickness of 1/8" (3mm) sheet metal) must fit completely between frame rails and may not extend below or attach to the stock front bumper.
- 47.2 Overhead Oiling Systems - Aftermarket overhead oiling systems for the camshafts are permitted.
- 48 OIL CRANKCASE BREATHER: The only locations that the crankcase may have a breather is under the carburetors at the stock outlet and/or in the oil fill cap. This breather may not be evacuated through the exhaust pipe (header). There may not be any additional breather holes for the crankcase. Breathers and hoses must remain within the engine compartment. Baffles used in the hoses are permitted.
- 49 OIL FILTERS, REMOTE: Remote oil filters are permitted and must be mounted in the engine compartment only. Inside or outside mounting of the remote oil filter to the frame rail is permitted. The remote oil filter must be located in a position where it cannot be easily damaged in the event of an accident. Remote oil filters may not be mounted below the bottom of the front bumper.
- 50 PICKUP POINTS & SPACERS: Absolutely no modifications of the frame pickup points, rear end pick up points or spindle points are permitted. A maximum 3/4" (19mm) wide spacer may be used on all 1/2" (12.7mm) suspension bolts.
- 51 RACK & PINION STEERING: Only the rack & pinion steering box as currently delivered and stamped U.S. Legend Cars International (or Mid-State Machine) is permitted. A Stiletto-brand or unmarked rack & pinion steering box is not permitted. The rack and pinion mounting plate measures 3 7/8" to 4" (9.85 to 10.16 cm) from the bottom of the frame rail to the top of the mounting plate (see diagram on page 96). A 4"x 4" x 1/8" (10.16 x 10.16 x 3mm) plate will be allowed to be bolted (not welded) under the steering rack mounting plate. This will be a 4"x 4" x 1/8" (10.16 x 10.16 x 3mm) plate with three holes using the steering rack studs to secure it.
- 52 RADIOS PROHIBITED: No drivers or crew members are permitted to use one-way or two-way radios on race day, including practice sessions. Radio wiring harnesses are not permitted in a Legends Car during ILSA sanctioned competition. Radio ear plugs are not permitted. Raceceivers (U.S. Legend Cars International Part No. 975000X069) will be used only at tracks that mandate them.
- 53 RADIUS RODS/PANHARD BAR: The radius rods and pan hard bar must remain within the stock dimensions (radius rods - either 6.5", 11.0" or 12.0" (16.5, 27.94, 30.48 cm) in length / pan hard bar - 23.5" (59.69cm) in length), aluminium thickness, location, and configurations of the original, as currently delivered by U.S. Legend Cars International. Each length measurement will have a tolerance of +/- 1/8" (0.125") (3mm). Steel radius rods or pan hard bars are not permitted. The 11.0" and 12.0" (27.94 & 30.48cm) rods may be interchanged anywhere on the car as long as the car still meets all other specifications contained in this rulebook.
- 54 REAR AXLES: The long and the short rear axles must remain stock, within the stock dimensions, steel thickness, location and configurations as currently delivered by U.S. Legend Cars International and may not be reinforced in any way. If one piece axles are used, they must be stamped ILSA and be as delivered by U.S. Legend Cars International Any type of aftermarket axle, an axle modified for lightening purposes or

axles not in accordance with the above rule will result in an immediate disqualification and confiscation of the illegal parts.

- 55 REAR ENDS: Only 10 bolt pattern/wide flange (5/8") (15.87mm) Toyota, locked-steel rear ends are permitted. All rear end components, to include the housing, and pickup points must meet the specifications of the stock components as delivered by U.S. Legend Cars International. The rear end must be locked (all spider gears welded or steel spool of a minimum 6.0 pounds (2.72kgs), as currently delivered through U.S. Legend Cars International only). No limited slip differentials, aftermarket differentials, quick change rear ends, floaters, homemade or otherwise are permitted. Only OEM bearings are permitted. No hemispheric, ceramic coated or similar type bearings are permitted. No spacers are permitted between the backing plate and bearings. Axle tube material must be 3" (76.2mm) O.D. and .120" (3.00mm) wall thickness. A "Double shear" rear end housing is available through U.S. Legend Cars International. (competitors are allowed to up-grade to the stock U.S. Legend Cars International "Double shear" specifications).
- 56 RIDE HEIGHT: The car may have no less than 3 ½ inches (88.9mm) between the bottom of the frame rails (not the weld) and the ground. This measurement is to be checked without the driver in the car, as raced, without lifting of the car of any kind. The checking of ride heights will be measured in a predetermined area as set out by the INEX SA tech official. This area will be set out in good time before the event in order to allow competitors to pre-tech their cars. This area may not be contested after the fact.
- 57 RUNNING BOARDS: The running boards must remain within the stock dimensions, steel thickness, location and configurations as currently delivered by U.S. Legend Cars International and may not be reinforced in any way.
- 58 SHEET METAL: The minimum thickness of sheet metal is .036" (1.0mm). The rear deck sheet metal (including the package tray behind the driver) may not be removed or altered in any way unless a fuel cell access hole is used. The fuel cell access hole must be covered with a sheet metal plate and secured at all times when the car is on the track.
- 59 SHOCKS: All Legends Cars must use INEX (logo stamped Bilstein) shocks as currently delivered by U.S. Legend Cars International. Shock numbers must be made visible at the request of an IRCSA/ILSA inspector. Changing or altering the shock or fluid inside is illegal. Altering or tampering with the shocks, or competing with same, will result in a suspension from one year (first offense) to a lifetime ban (multiple offenses). Shocks may be turned upside down and/or the upper part of the rear shock may be mounted on either side (inside or outside) of the frame.
- 60 SPINDLES: The spindles (and pickup points) must remain stock, within the stock dimensions, thickness, location and configurations as currently delivered by U.S. Legend Cars International. Repairing a broken or cracked aluminum spindle is not allowed.
- 61 SPRINGS: All Legends Cars must use 10" or 8" springs. Any spring weight combination and aftermarket springs of stock design are acceptable. Only one spring is permitted per shock. Spring rubbers are not permitted.
- 62 SPROCKET ADAPTERS: The sprocket adapters must remain stock, within the stock dimensions, steel thickness, location and configurations of the original, as currently delivered by U.S. Legend Cars International  
Set screws for the sprocket adapter nut are permitted. Lightening the sprocket adapter for weight savings in any way is illegal.
- 63 STEERING COLUMN: The steering shaft or steering column bracket may be modified for driver comfort or safety by altering the length of the shaft or by altering the steering column bracket that connects to the

dash (if the “dash” bracket is replaced, steel brackets must be used, no aluminum). Bearings are not permitted to be used in mounting the steering shaft. Stock-style bushings or steel rod-ends must be used. Intentional lightening for weight saving measures is not permitted. A hose clamp or shaft collar is mandatory on the steering column in the engine compartment directly against the firewall. There can be no more than ¼” (6mm) gap between the clamp (collar) and the bushing (See diagram in Appendix). Modification of the driver’s compartment roll cage is not permitted.

63.1 Steering Quickeners - Steering quickeners are not permitted

63.2 Steering Shafts - Tubing used for steering shafts must be stock as currently delivered by U.S. Legend Cars International and may not be reinforced in any way. Upgraded steering joints are acceptable.

64 STEERING WHEELS: Larger or smaller steel steering wheels are allowed, aluminum steering wheels are allowed. Racing style, quick release steering hubs are mandatory.

65 TYRES: The tyres must be sets of 4 x Soft Compound tyres – Yokohama AO48 – 205/60/13 as delivered by IRCSA/ILSA. Tyres may not be soaked, softened, grooved or recapped. Tyres must be purchased from IRCSA/ILSA.

65.1 Hardness - If any tyre is softer than 58 points on the INEX Inspector’s durometer, the driver will face suspensions from one year (first offense) to a lifetime ban (multiple offenses). Tyre warmers and any other means of artificially warming tyres are prohibited.

65.2 Tread Depth - When the top of the wear-bar indicator appears at two spots in a row on the tyre (side-by-side or in the same groove - i.e. outside groove) or the tread depth is 2/32” (1.6mm) or less on any two (2) points in the tread (measured from the bottom of the groove, not at the top of the wear-bar) (“tread” will be defined as 6” (15.24cm) across the tyre, to be measured from the center 3” (7.62) both ways), that tyre will be confiscated, destroyed or drilled by the technical inspector. There is no disqualification for violation of this rule unless more than one tyre is below the minimum tread depth. If this rule is violated on two different occasions at the same event or two tyres on the car at the same time, then that driver will be disqualified. If the wear bar is cut out or tampered with, that tyre shall be destroyed immediately (even if it has more than 2/32” (1.6mm) tread on it) and a disqualification will be applied. Drilled or damaged tyres may not be patched or repaired in any way!

65.3 “Dry Tyre” Rule - It is prohibited to use traction compounds or any substance that might alter the physical properties of a tyre as supplied by the manufacturer. Tyre cleaners/shiners, tyre softeners, track adhesives, brake fluid, diesel fuel, etc., will not be permitted on the tyres. Any tyres with signs of these products on or inside them will be impounded for further testing. Tubes will be allowed.

Each competitor will be allowed a maximum of 8 tyres for the official rounds or the 2024 INEX Legends championship. Tyres follow the driver.

All tyres will be marked with a bonded register number which will be bonded to the tyre-wall. A register will be kept of all tyres issued through the racing season January 1<sup>st</sup> – December 31<sup>st</sup>. Any driver competing without the registered tyre on his car will face automatic exclusion from that heat and no points will be scored.

The tyre skimming rule applies. Drivers may not skim tyres. With every new tyre used after the first 8 tyres the driver will be penalized 100 points for every new tyre. This will be known hereafter as the 100-point penalty rule.

The tyres will be registered to the car number. Drivers may NOT trade out tyres amongst each other. Should a driver make use of another car the registered tyres must be transferred to that car along with the driver’s race number. It is the driver’s responsibility to carry race numbers in the event of such a car swap.



A competitor may nominate his/her first set of tyres with which to begin the season. Said tyres must be tagged by the INEX official before official practice of the first round of the series. The nominated tyres must have no less than 3mm of tread. The lowest point will be measured at the innermost point of the outer tread blocks on each side of the tyre width. All further tyres must be purchased via the INEX Legends dealer, IRCSA. These tyres will be tagged at time of purchase and noted on the register. Should a tyre be damaged due to a collision whilst on track at an official ILRCSA/ILSA sanctioned event the tyre must be deemed unserviceable by the INEX tech official. The collision damage must be brought to the attention of an INEX official within one hour of the incident and an INEX incident report must be completed in full and be signed off by the INEX official. The driver may then nominate a tyre for that event only. The INEX official will approve said tyre and mark the nominated tyre with spray paint. This tyre may only be used for the remainder of that event. The tyre must be replaced for the next event and the tyre register will be amended. The 100-point rule will not be enforced on this occasion.

In the event of a tagged tyre being damaged outside of an official event INEX sanctioned race the 100-point rule will be enforced. If a tyre is damaged due to "flat-spotting" and needs to be replaced the 100-point rule will be enforced upon replacement of said tyre.

The tyre register will remain in the possession of the INEX tech official. A driver may purchase his/her entire tyre allocation at once. Upon purchase these tyres will be tagged and noted on the register.

70. **TRACTION CONTROL DEVICES:** No electronic or computerized wheel spin/traction control devices are permitted. Any driver caught using these devices will face suspensions from one year (first offense) to a lifetime ban (multiple offenses).
71. **UPPER CONTROL ARMS:** The upper control arms must remain stock, within the stock dimensions (4.25" +/- 1/8" in length) (10.80cm – 3mm), steel thickness, location, and configurations as currently delivered by U.S. Legend Cars International and may not be altered in any way.
72. **WEIGHT:** The minimum car weight is 1100 pounds (498kg). The present of weight from front to rear will be no more to the rear than 52.0% without driver. The weight percentage from left to right will be no more to the left than 52.0% with the driver as raced. The minimum weight of the car with the driver is 1300 (590kgs) pounds. Competitors are not permitted to add fuel after an event to meet minimum weight.
73. **WEIGHT SAVING MEASURES:** Lightening "stock" components by shaving, milling, drilling or any other method is illegal. Any item on a Legends Car that is used (other than what is mentioned in the rules) as a weight saving method is considered illegal. Non-stock aluminum or titanium components are considered illegal and will be confiscated immediately. Components must remain the same material as delivered by U.S. Legend Cars International unless specified in this rulebook.
74. **WHEELS:** Any type of automotive steel wheel that has a 13" diameter, a 7" width and the offset of 3" to 3 1/4" from back rim edge to back of wheel center is permitted. The minimum weight of a tyre and rim/wheel must be at least 31.0 pounds (14.06kgs). All wheel weights must be covered with duct tape. Bleeder or relief valves are not permitted in the wheels.
75. **Basset Wheels.** The use of the Basset wheels will be allowed only for drivers that weighs 85kg or more.
76. **WHEELBASE:** All cars must compete with 72 3/4" to 73 1/4" (185 to 186.05cm) wheelbase on either side.

Measuring wheelbase - The measurement will be taken with the front and rear tyres on one side in line with each other. To determine this, the measuring tool or tape measure must touch three points. These points are the front of the rear tyre sidewall and the front and rear of the front tyre sidewall. The measurement is then taken from the front edge of the front wheel to the front edge of the rear wheel. The

process is the same when measuring wheelbase on the opposite side.

77. **WIDTH:** The total overall width of the car (front and rear) may not exceed 60 inches (152.4cm). The car must be able to roll freely through a 60 inch (152.4cm) wide opening as raced.

77.1 Rear Offset: There must be a minimum of 6" (15.24cm) between the inside edge of the rear brake drum and the rear frame rails (directly below the centerline of the rear-end housing) on both sides. No wheel or axle spacers are permitted.

\*Enforcement and Infraction Penalties of the Ride Height, Wheelbase and Width Rules:

After qualifying or after a race, if a car is found to be in violation of the ride height, wheelbase or width rule, and only if requested by the driver, the driver may have five (5) minutes to find the reason why the ride height, wheelbase or width does not meet the rules. It is the driver's responsibility to find the reason (such as a bent part that would directly affect the infraction) before the car leaves the tech area. It is not the tech inspector's responsibility to find the reason. If a reason cannot be found and the car leaves the tech area, the driver cannot bring it back to the tech inspector showing or explaining a damaged part which affected the ride height, wheelbase or width. This must all be done within the tech area and within the specified time period.

If no reason (such as damaged parts that would directly affect the infraction) can be found, this will result in an immediate disqualification.

78. **WINDSHIELDS/SCREENS:** All cars must have either a screen or lexan windshield in the front window area. A lexan sun visor is also permitted in the front window. If a "wet" race is announced the windshield may be removed provided a replacement sun visor with the series sponsor is fitted in its place.

## H1 ENGINE SPECIFICATION RULES

### YAMAHA XJR 1250 "SEALED"

\*\*\*The XJR 1250 are sealed engines. Tampering, removing, altering the engine seals will result in a suspension from one year (first offense) to a lifetime ban (multiple offenses). Competing with an engine that has been altered may result in a suspension for both the owner and driver. Additional fines may be applied also.

If you purchase an engine from a questionable source, it is best to get it checked by an ILSA authorized sealed engine builder! All repairs requiring removing the seals(s) must be addressed by INEX Legends South Africa. Only the 1250 sealed engine will be permitted in the ILSA Series. All cars must have 3 seals. A Diff Seal, a Camp Chain Seal and a Cylinder Head Seal as provided by IRCSA.

1. XJR 1250 ENGINE SPECS: The only modifications allowed to the factory sealed engines are:
  - A. Changing carburetor jets
  - B. All stock carburetor adjusters may be used
  - C. Adjusting the valve shims
  - D. Installing an aftermarket clutch and spring of original design (no aluminum clutch plates). A double pressure plate spring may be fitted.
  - E. Upper head oilers, heavy-duty valve springs, "Pinned." Camshafts and steel sleeves are permitted only if installed by an INEX authorized sealed engine shop.

- 1.2 OIL PUMP - The stock oil pump may not be modified in any way. Relief valves may be shimmed.
- 1.3 OIL PAN - The stock oil pan may not be altered, modified or include any additions to alter the path of the oil.
- 1.4 Cylinder Sleeves -Worn cylinder bores may be replaced with aftermarket sleeves. Oversize pistons are not permitted.

## 2. Engine specifications.

Yamaha XJ 1250 engine specs will apply supplied by the authorized dealer IRCSA in SOUTHERN AFRICA  
Engine bore and stroke must remain stock at Bore – 79mm  
Stroke – 63.8mm

2.1 CYLINDER HEAD: The original equipment cylinder head of an XJR 1250 engine must remain in unaltered “as cast” condition with the exception of machining the gasket surface (no angle milling allowed). Valve seat inserts may be replaced with OEM or aftermarket seats of original dimensions. No port alterations of the intake or the exhaust below the seat are permitted. O-ringing the head gasket seal area is not permitted.

2.1.1 Combustion Chamber -Relief cuts for cc balancing is not permitted.

2.1.2 Repairing Heads -A combustion chamber may be repaired by welding and grinding back to the official “stock” configuration of the combustion chamber.

## 3. Camshaft

Camshaft timing must remain in the standard position. The stock position is determined as follows: - When 1 and 4 pistons are at absolute top dead center, the alignment holes in the camshaft “anti-float” web must appear directly within the parameters of the alignment holes in the No 3 camshaft cap on both camshafts simultaneously. The alignment hole of the camshaft may not exceed the alignment hole of the cam cap. The inlet and exhaust camshafts are cast marked IN and EX. These may not be swapped around. Camshafts must remain in stock dimensions – lift, base circle and duration.

## 4. Compression ratio:

The maximum engine compression ratio may not exceed 10:1

The compression ratio will be determined by use of a burette using fluid made up of 50% benzene and 50% aft. (automatic transmission fluid) this mix of fluid will be used with all “CC” checking procedures to maintain maximum consistency across all engine building and inspections. Should components; i.e.: the barrel or cylinder head, require surface machining additional head gasket blades may be used to keep the “CR” within the above mentioned parameters.

## 5. Cranking Compression:

The cranking compression of a sealed 1250 engine must be at or below 165 p.s.i. at any time (hot or cold) on at least three (3) cylinders with the ignition off and the throttle wide open with the carburetors on the engine, and all four spark plugs out. Ten to twelve revolutions of the engine will determine the total compression of a cylinder. There is no tolerance for engines over 165 lb. The gauge used by the tech inspector is the “official gauge.” INEX highly recommends having the technical inspector to check cranking pressure prior to competition.

## 6. Valves and Seats

Only stock Yamaha XJ1250 valves may be used as supplied by US Legends International. No modifications are permitted to these valves. Only stock valve lifter and adjustment shims may be used. All valve seats will be cut to a standard 30° - 45° -60° valve seat angle combination with a minimum of 0.5 mm width of the 45° angle.

7. **ValveSprings:**  
The valve springs may be replaced with aftermarket magnetic steel springs. Only stock steel valve spring retainers and clips/keepers are permitted. No titanium or other lightweight alloys are permitted.
  
8. **Crank Shaft:**  
The crank shaft must remain as stock as delivered new by U.S. Legend Cars International. Modifying the throw balances or weight of the crank is illegal. Polishing the crankshaft is illegal. Minimum crankshaft weight will be 27 pounds. (12.247kg)
  
9. **Transmissions:**  
The transmission and transmission gears must remain stock Yamaha XJR1250 (sealed) in the stock configuration as delivered by U.S. Legend Cars International. They may not be lightened in any way. The transmission gears may be shimmed only for the purpose of proper engagement. Standard and aftermarket shims may be utilized.
  
10. **ENGINE CLAIM**  
The purpose of the claim is to provide a “safety valve” to help keep the series competitive and to keep the cost of racing affordable. Only drivers (or legal guardian) that are current ILSA members may claim an engine after the main event for \$5,670.00 (ZAR equivalent) cash or electronic transfer only. That person must show their membership card to submit a claim.
  - a. **POSITIONS THAT MAY CLAIM AN ENGINE:** Any driver (or legal guardian representing the driver) finishing in the top ten positions in the event and on the lead lap of the feature event may claim an engine from a top five finisher within the same race. Should there be more than one claim to an engine, the driver in the highest finishing position has the first right to the engine claim.
  
  - b. **TIME OF THE CLAIM:** In order to file a claim, the claimer must stop their car at the designated technical inspection area prior to going to their trailer in the pit area. At this time the claimer must notify the ILSA technical inspector of their intentions to file a claim. The membership card, claim card and full payment must be presented to the ILSA tech inspector no later than ten (10) minutes after the finish of the race. Once a claim is made, it may not be withdrawn. The serial number on the casing of the engine must be written on the claim card by the ILSA official immediately following the claim.
  
  - c. **COMPONENTS OF THE ENGINE CLAIM:** Only the top five feature finisher’s engine including carburetors, alternator, and starter may be claimed. Not included in the engine claim are the ignition electrical components, ignition box, coils, header, oil cooler, remote filter, sprocket adaptor, clutch slave cylinder, and air ducts.
  
  - d. **CLAIM PAYMENT:** Cash or certified check in the amount of \$5,670 (equivalent in ZAR) along with a claim card must be presented to the tech inspector. The tech inspector must produce (but not give) the payment to the claimee before the engine is removed. All certified checks shall be made out to the claimee for the proper amount written clearly and legibly (unless “Option B” is chosen - then the certified check shall be made out and given to ILSA, Corp.).
  
  - e. **CHOICE OF THE CLAIMED ENGINE:** At the time of the claim, the claimer must choose on the claim card either “Option A” or “Option B” as follows:  
“Option A”: The claimer takes immediate delivery of the claimed engine. The claimer is then responsible for the legality of that engine. If the engine is sealed, the claimer is responsible for all engine components not secured by the seals. (The engine builder is still responsible for engine components secured by seals.

“Option B”: The claimer may choose to have the ILSA tech inspector send the claimed engine to IRCSEA/ILSA headquarters (or an ILSA -approved inspection site-determined by the Executive Director) for inspection for an additional fee of \$250 (ZAR equivalent payable to ILSA). The ILSA representative at the track will be responsible for holding the engine until the time of shipment (this cannot be done after the claimer leaves the track with the engine). The claimer must pay for shipping charges and inspection fee and the engine must be sent to ILSA within seven (7) days of the claim by the ILSA representative. If the engine is not at the ILSA inspection site within seven (7) days, the payment will be given to the claimer and the engine will not be checked for legality. The engine will become the property of the claimer immediately.

Upon inspection of the claimed engine, if the claimed engine is found illegal in any way, the check for \$5,670 (ZAR equivalent payable to ILSA) will be returned to the claimer (who is still responsible for shipping charges to the inspection). All illegal engine components will become the property of ILSA. Legal components of the engine will be returned only at the discretion of ILSA and at the expense of the claimer. The claimer may also be fined and must pay all fines prior to the legal components being returned. The driver may also face possible additional penalties by ILSA. All illegal 1250 engine components (items secured by seals) will be impounded and become the property of ILSA. It will be the engine builder’s responsibility to reimburse the driver of a car found with illegal components secured by seals.

If the claimed engine is found legal, the owner of the engine being claimed receives the \$5,670 and the engine will be sent to the claimer (who is responsible for the shipping charges of the engine’s shipment).

## **J1      PROTESTING SPECIFIC COMPONENTS ON LEGENDS CARS**

The purpose of the protest is to provide a “safety valve” to help keep the series competitive and to keep the cost of racing affordable. Only current ILSA members or associate members may protest a component. (That person must show membership card to submit a protest.) Any specific engine, rear end, or suspension components of a competitor’s car may be protested by any driver finishing that feature after the race for the amount designated in terms of cash or certified check.

Note: “On track” race calls cannot be protested to ILSA.

**TIME OF THE PROTEST:** The protester’s membership card, protest card and full payment (in cash or certified check no personal checks) must be presented to the ILSA tech inspector no later than ten (10) minutes following the finish of the race. Once a protest is made, it may not be withdrawn. All purse and points are to be distributed after a decision on the protest has been made. Tech inspectors will not accept verbal protests or protests which are not accompanied by the required protest fee, protest card and protester’s membership card. If a technical inspector is not in attendance, then all protests should be given to the INEX competitions/race director.

**CHECKING THE PROTEST:** The protested component will be removed from the car or made available for inspection by the protested team’s crew and inspected by the ILSA tech inspector. The following people will be permitted to be present at the protest site: protested driver and crew (the crew shall leave once the part is removed), protester, ILSA tech officials and a speedway management representative. If a decision at the track cannot be made, then the component will be sent to ILSA for a final decision on legality. On a protest, it is the driver’s duty to prove his legality, not the tech officials or protester’s duty to prove the violation.

**WHEN THE PROTEST FINDS A LEGAL COMPONENT:** After inspection, if the protested component is found legal, the protest money will be given to the driver of the car from which the component was protested (less reasonable inspection fees and shipping charges determined by ILSA). The shipping costs of an engine to an engine rebuild is not covered.

**WHEN THE PROTEST FINDS AN ILLEGAL COMPONENT:** After inspection, if the protested component is found

illegal, the driver of that car will be disqualified from that event, forfeits all prizes and honors earned at the event and face the possibility of more penalties at the discretion of ILSA. The illegal parts will also be confiscated by ILSA. The protest money will be returned to the team filing the protest. The driver who was found illegal will be responsible to pay for inspection fees and shipping charges in the form of a fine.

REFUSAL OF A PROTEST: If the driver of the protested car does not allow inspection under these terms, he will be disqualified, forfeit all points, purse monies, prizes and awards earned at that event and possibly suffer more penalties as determined by ILSA. The car will also be suspended from competition.

ILSA may penalize the author of a protest deemed to be malicious, spiteful, or who otherwise acts in bad faith.

- A driver may only be protested by one other competitor at each event. (If more than one protest is filed against a competitor, the driver with the higher finishing position in that race will be allowed the protest.
- No driver may file a protest more than 3 times during the calendar year.
- Protestor must verify that the tech inspector has the special equipment necessary for the test, if applicable.

Protest Fee Schedule for Legends Cars:

Choice of one (1) of the following items to be protested:

- R1000.00 - Compression Ratio (Choice of any 2 cylinders)
- R 1000.00 - Bore Size (Check all four cylinders with bore gauge)
- R 1000.00 - Stroke
- R 4000.00 - Crank Shaft (lightened / out of engine)
- R 4000.00 - Rods (stock, polished, lightened / out of engine)
- R 2000.00 - Ported & Polished Head (check intake & exhaust)
- R 500.00 - Air Filters (Velocity Stacks and size of filter)
- R 1000.00 - Cam Shaft Lobes (check intake & exhaust lobes)
- R 750.00 - Alternator (working & wired properly)
- R 2000.00 - Fuel (Laboratory Test)
- R 1000.00 - Exhaust System (check header and/or muffler)
- R 1000.00 - Total Weight (between min. & max. weight)
- R 1500.00 - Rear End Gears (Locked)
- R 1000.00 - Shocks (each shock)
- R 1000.00 - Spindle (Left & Right)
- R 1000.00 - Driveshaft (stock)
- R 1000.00 - Wheel Offset (Check all four wheels)
- R 1000.00 - Wheel Weight with Tyre (Check all four wheels)
- R 1000.00 - Front Bumper or Rear Bumper meets all specs.
- R 2000.00 - Carburetors
- R 500.00 - Durometer test of tyres
- R 2000.00 - Engine Seals

\*TBD - Reasonable fee to be determined by the ILSA official for other specific items.

No protests, complaints, incidents etc. will be issued to the INEX race secretary. All incidents however minor, will be submitted in writing to the Official INEX Technical consultant, or the INEX Competitions director should he/she not be present within a half an hour after the incident has taken place or after the completion of that heat.

These rules and/or regulations apply to all ILSA -sanctioned events.

## RACE START

In addition to item GCR 121 (ix) of the MSA handbook, any competitor absent from the drivers briefing will be penalized by 50 points. All drivers are to form up in grid order, as described in the SSR's, either in the pit lane or pre-race paddock. The safety car will wait at the start line for the drivers.

Competitors will proceed onto the track and use the lap to warm the tyres and engine. All cars will stop on the grid in their correct grid positions. Once the safety car moves forward, the competitors must follow for one lap at a safe distance to the safety car. The safety car will exit the track via the pit lane and green flag/light conditions must prevail on entering the pit straight at the COC's discretion.

Drivers must retain their grid positions in close proximity to the lead driver. The Pole driver controls the pace. No driver may overtake or fall back on approach to the start line in. Any driver creating a gap on the run up to the start line may be penalized at the COC's discretion and could result in a 30 second time penalty for a rolling start infringement. Starts will be by rolling start.

### 1.2 GRID POSITIONS

Grid positions will be by ball-draw, determined by the entry notifications received latest 48 hours prior to official practice, which will take place at the latest, on the day of the race one hour prior to drivers briefing, the draw time will be posted on the official ILSA legends notice board. It is the responsibility of each driver to be aware of the draw time as indicated on the notice board, and to attend the draw. If a driver is not in attendance at the draw, and without notification of intended entry as above, he/she will start at the back of the grid for all three heats. Grid positions for the second heat will be in reverse (inverted) order of the draw. The final heat grid is by points scored from the first two heats in order of highest scorer starting at the back and lowest score takes pole position, with the exception of Young Lions. The ILSA secretary will keep the race officials up to date at all times with grid positions and other changes. Any specific change or requirements to the grid needs to be clarified with the race secretary timeously to allow for notification to the race officials.

Pole position will be on the inside to the first corner, unless otherwise ruled by the ILSA competition director and the event COC. Should there be no notification of grid layout on the notice board, it will be assumed that pole is as per all other categories on the day.

### 1.3 COMPETITION NUMBERS

All competition numbers and names shall be clearly visible to officials.

Numbers size 21 cm in height x 11 cm width per digit, to be placed on the front quarter panel, either in black or a contrast colour if the race car colour is black or dark so that it is clearly visible.

Digits shall be of the classic type. I.e.: 1 2 3 4 5 6 7 8 9 0

The number must also be displayed on the nose (*left* front fender) of the vehicle, legible from the front, on at least one side. Number size minimum per digit: 16 cm x 12 cm.

Drivers' names must be displayed on the roof above the doors. Lettering size must be a minimum of 5 cm in height.

Sponsor branding is to be included on the vehicles, however it must not interfere with the visibility of race number or the name of the driver.

Failure to comply with the above will result in a 10 second time penalty/ 50 points.

### 1.4 RACE

The ILSA series requires each round to be made up of 3 heats per race meeting to align with the international Legends racing.

All race instructions to the event organizers and race COC's and officials may only be negotiated via

the official INEX technical director or INEX competitions director. No competitor may give instructions to the organizers or race officials, unless the ILSA TC/ competitions director is also a competitor. Should any person be found to have instructed an official, the associated driver(s) will be disqualified and all race scores for that race will be forfeit.

INEX Legends Cars series is a NON-CONTACT race format. Any damage caused to your own or another race vehicle will be deemed an offence and the driver may receive either points penalties (minimum 50 points), disqualification from the event or be banned from the ILSA race series, dependent on the outcome of an official protest or inquiry with either INEX Legends internal representatives or the governing body or race organizer or at the discretion of the event COC.

## **L1 DRIVER CONDUCT**

Refer to MSA SSRs 45 to 66 (where applicable)

- SAFETY CAR
  - DRIVERS ON THE COURSE
  - RACING CONDUCT
  - OVERTAKING, RULE OF THE ROAD
  - SAFE DRIVING
  - STOPS AT THE PITS
  - INCIDENTS, ACCIDENTS AND RETIREMENTS
  - WITHDRAWAL FROM RACE (GCR 110)
  - PIT ATTENDANTS
- a) Drivers may only make one (1) change of direction between exiting one corner and approaching the next corner. Any further changes of direction will be regarded as 'weaving' and offenders will be penalized accordingly.
- b) If a car has left the circuit with all 4 wheels, it shall re-join the circuit at the nearest point to the exit from it, compatible with safety and without prejudicing a fellow competitor. Leaving the circuit (with the resultant effect of missing a corner or skipping a chicane) and in so doing gaining an advantage by effecting an overtaking maneuver or preventing another competitor from overtaking, requires that the advantaged competitor will be compelled to allow the following vehicle to overtake him, so as to forfeit any advantage gained. This must be done within the next 2 corners, without any re-overtaking of the vehicle allowed through before a further corner has been taken. Failure by an advantaged competitor to forfeit the advantage gained as per the aforementioned shall render the offender liable to be penalized (30 second time penalty/50 points) by ILSA or the clerk of the course.

Driver conduct: It is at the discretion of the ILSA race director to deduct points/suspend/disqualify a competitor for bad sportsmanship either on or off the track.

## **L1 ILSA POINTS SYSTEM**

The following rules will determine points awarded throughout the ILSA Series:

Only ILSA members who have current paid up membership will be eligible to compete. Points will be scored over 2(two) heats and a feature (Final) race in one event.

Two race heats and a feature race will be considered as one round of the championship series.

Points are allocated as follows:

Placed: Points awarded

1<sup>st</sup> 200

2<sup>nd</sup> 185



3 <sup>rd</sup>	175
4 <sup>th</sup>	165
5 <sup>th</sup>	155 etc.

No points will be awarded for a DNS or a DNF

#### 1.2 Equal Results Rule

If the Category Championship points or Overall winner Championship points on the day of the Championship ends to be a draw between 2 or more INEX drivers the following ruling will be applied to determine the outcome:

- The driver who have won 2 of the 3 races for the day between the drivers that is equal will be granted the win for the day, or
- If the above options are equal a countback on the Category Championship point's standings for the category or the Overall Winner standings if the draw refers to the overall winner category will be used to determine the winner for the day on either category mentioned above.
- For Example - 2 Drivers end equal on the day after the 3<sup>rd</sup> race, and the most race win option is also equal, then the driver who have the most points for the Category Championship in question will be declared the winner.
- The countback option will only determine the winner for the day and do not change the actual points achieved for the day, as both drivers will receive the same point allocation for the achievement of the day in the Category Championship in question.

#### 1.3 Dropped Round Rule

Of the total rounds for the year, ILSA will allow one less round to count for the final series scores. Competitors may drop one rounds of points within a season. I.e. if series provides 11 rounds in that year, 10 of these will count towards the championship points.

A driver may not drop heats from different rounds.

Dates of the series races may be amended at the discretion of ILSA thru-out the year.

### **M1 MANDATORY VIDEO RECORDERS**

Video cameras are mandatory on all race cars and all footage is to be made available on request to the nominated INEX representative/official after each heat for download. It is the driver's responsibility to ensure that his unit is in working order at all times. 10 Points per heat will be deducted for non-submission of footage. Competitors without cameras will be disqualified.

#### END NOTES:

1. ALWAYS HAVE FUN!!!
2. This is a professional organization and all participants are expected to conduct themselves accordingly. Drivers (and their car owner if the driver is under 18 years of age) are responsible for the conduct of all persons connected with the team. Let's remember that in order for our sport to grow, we need the support of the spectator. Please give all spectators the respect that you would like to receive from them. We want to promote OUR sport as "A Family Sport." Any driver or associated person's misconduct shall be dealt with accordingly.
3. The Legends Cars are designed for racing use only! The car may NOT be modified for street use!
4. Pre-drive and Pre-event checks. It is the driver's responsibility to complete all checks before commencement of any drive, be it for practice or race meeting. Carefully check your car at all times before driving it. Pay particular attention should be paid to loose wheels, a loose seat, loose or damaged suspension parts and loose body panels and parts.

5. When first driving the car, it is highly recommended that you warm the engine up well before going on track. Following that, carefully sense any problems with the car on the warm up lap. If you encounter a vibration of any kind, you should pull the car into the pits immediately and have it checked.
6. Our members and associate members will always be “number one” to us, however some very important people are contributing their time and money supporting Legends Cars. Track owners and promoters work long, hard hours preparing for racing events at their facilities. They spend money and time encouraging old and new fans to come out and watch you race. ***PLEASE REMEMBER TO THANK THEM FOR GIVING YOU THE OPPORTUNITY TO RACE.***
7. The Press is also very important to our sport. They are doing their part in keeping Grass Roots Racing in the spot light. The Press is always looking for information. It is up to us (the sanctioning body, the promoters and the drivers/owners) to provide them with material related to our efforts.
8. The Series Sponsors are also very important to our sport.
9. Note these rules are subject to change during the racing season. The officials’ interpretation of these rules is FINAL.

#### AMENDMENTS

Controllers reserve the right, without prior notice, to introduce new regulations and or amend the existing regulations. The Controllers reserve the right, without prior notice, to introduce additions and/or amends the existing regulations should circumstance warrant. All additions / amendments to the regulations will be published on the official notice board and circulated to all competitors at least seven (7) days prior to a race meeting. MSA rules apply to any changes in the series race dates.

#### GENERAL

It is the sole responsibility of all drivers to ensure that their vehicles comply with the above regulations and all drivers/riders are therefore advised to obtain full safety and eligibility clearance from the relevant association technical consultant before entering their event.

# APPENDIX

## GUSSETS & MODIFICATIONS THAT ARE PERMITTED TO BE ADDED TO EXISTING LEGENDS CARS AND PARTS

### Front Clip Support

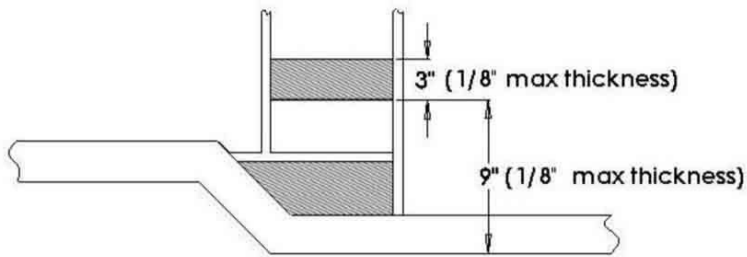

APPENDIX

### Upper Link & Rear Trailing Arm Pickup Points

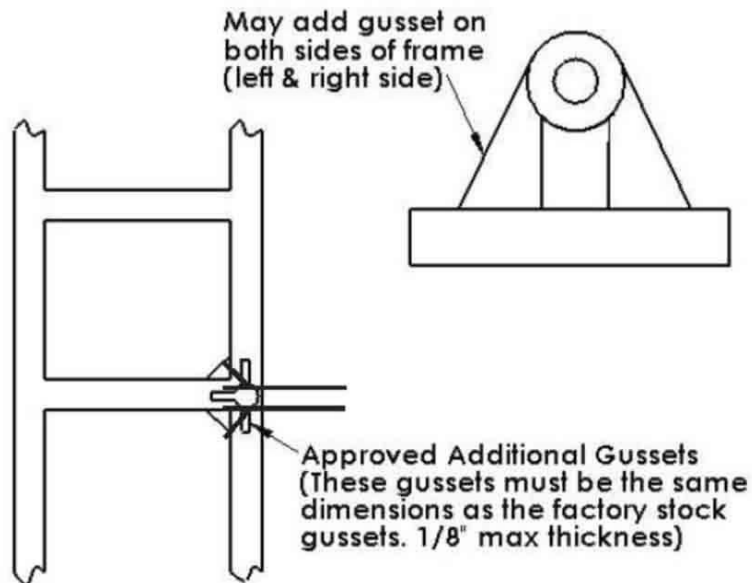

## Rear End Housing Upper Link & Rear Trailing Arm Pickup Point

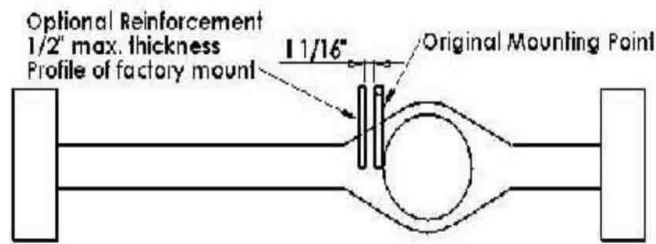

(This reinforcement will secure the opposite side of the rod end of the upper link)

## Back View of Housing

Approved Rear Gussets (Max. 3/16" thick)

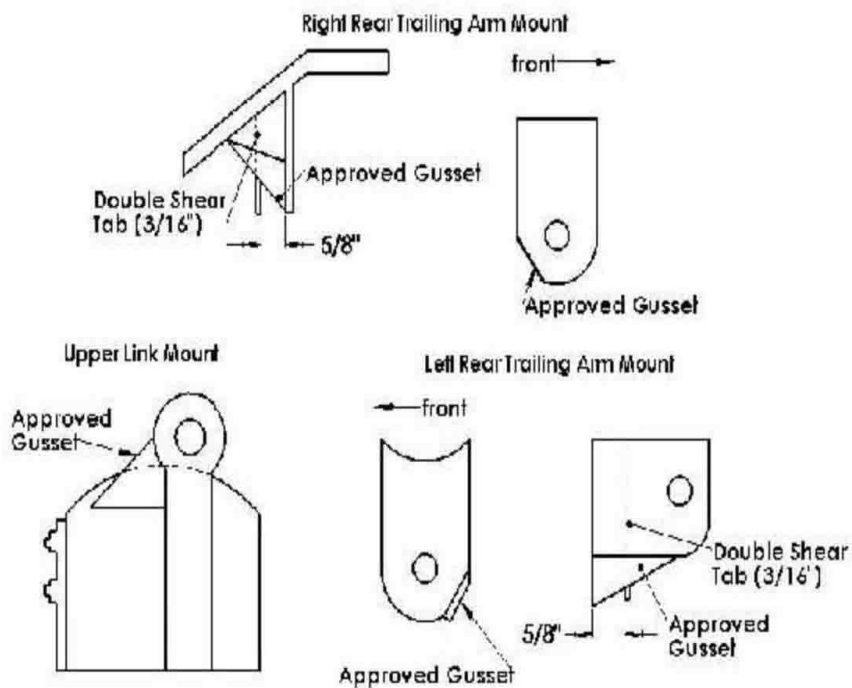

# Steering Rack Plate

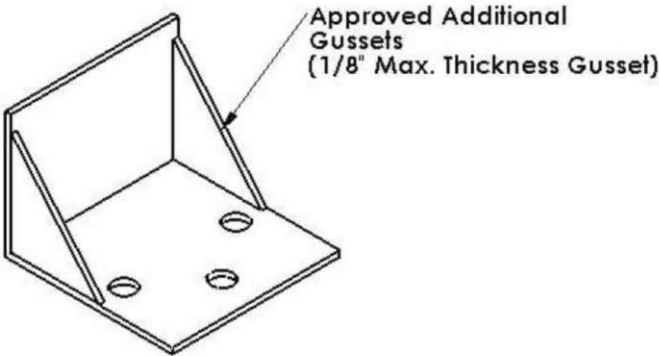

## Upper Link Double Shear Mount (Chassis Side)

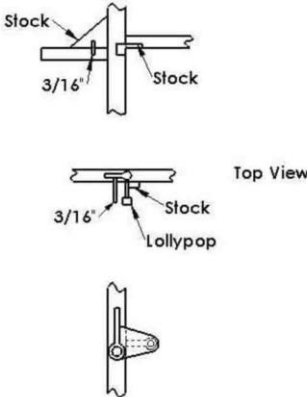

# LEGENDS CARS FACTORY STOCK SPECIFICATIONS

(These are some of the factory specifications. This is not a complete list of all the factory specifications. If the information you need is not listed in the rulebook, please contact U.S. Legends Cars for the correct factory specifications.)

## Shock Tower

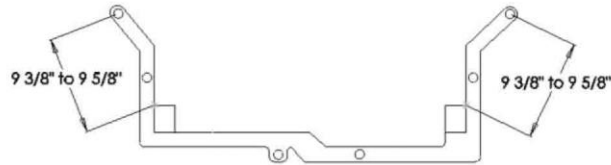

## Legends & Thunder Roadsters Rear End Housing

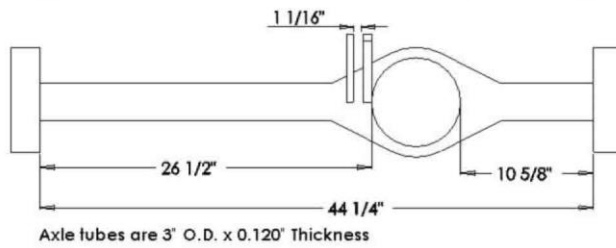

## Legends Shock Tower

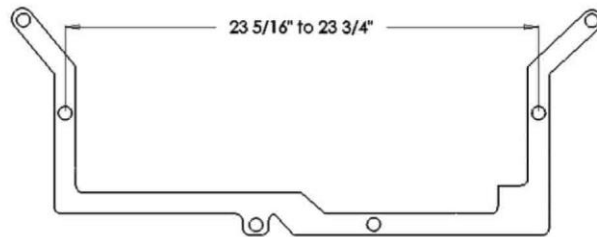

## Legends Left Side Motor Mount Pickup Points & Front Clip Measurements

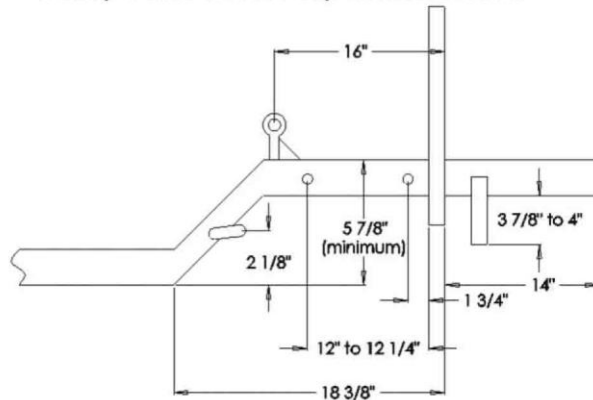

# Legends Right Side Motor Mount

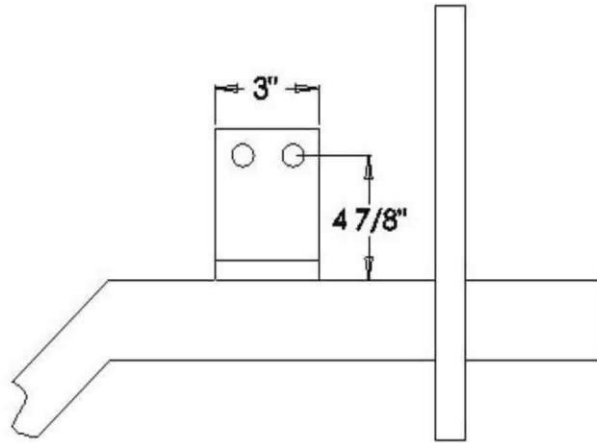

Aluminum mounts or extra holes are illegal.

## Legends Front & Rear Bumper

(1" Steel Tube)

(8 lbs. Max. Weight)

Reinforced Rear Bumper - (9 1/2 lbs. Max. Weight)

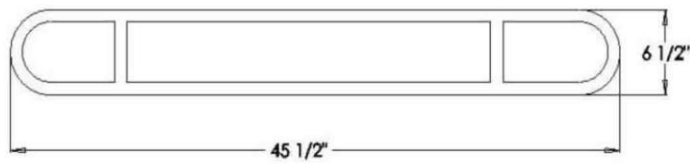

## Legends Right & Left Nerf Bars

Weight = 4 lbs. Max.

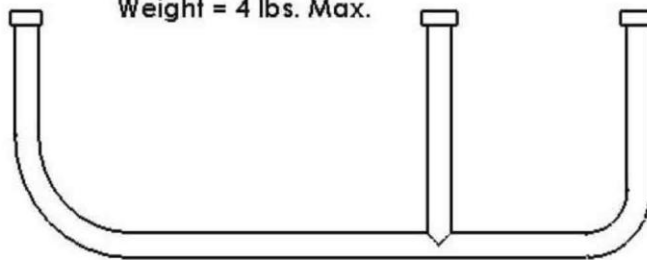

## Legends & Thunder Roadster Sprocket Adapter

2 1/4 lbs. min. Weight

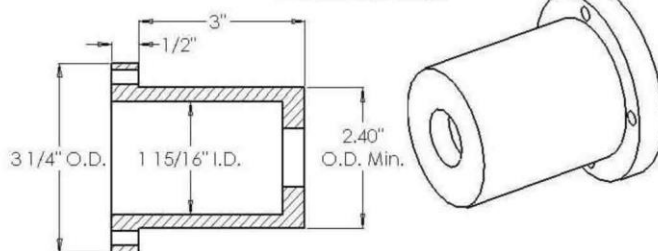

## Legends & Thunder Roadster Brake Drum

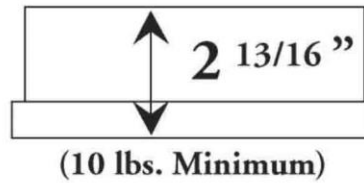

## Legends & Thunder Roadster Axles

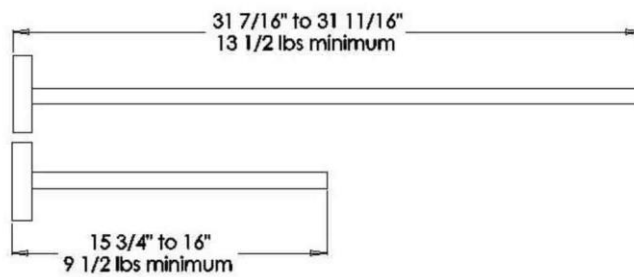

## Legends Upper Control Arm Front Mounting Point

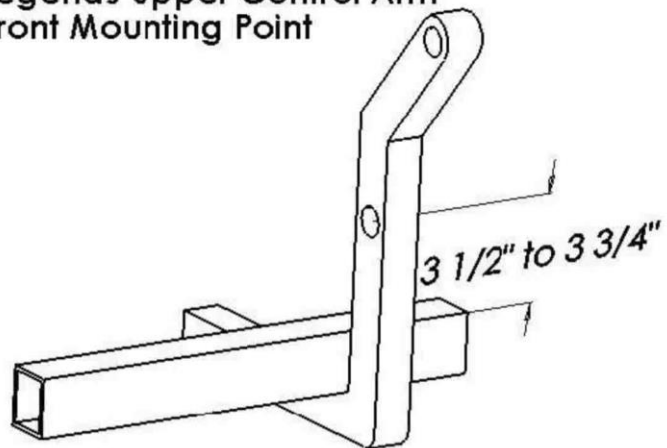

$3 \frac{1}{2}$ " to  $3 \frac{3}{4}$ " (from the top of the frame to the center of the pick-up point holes)

(MEASURED STRAIGHT UP AND DOWN)



### Legends Left Side Motor Mount

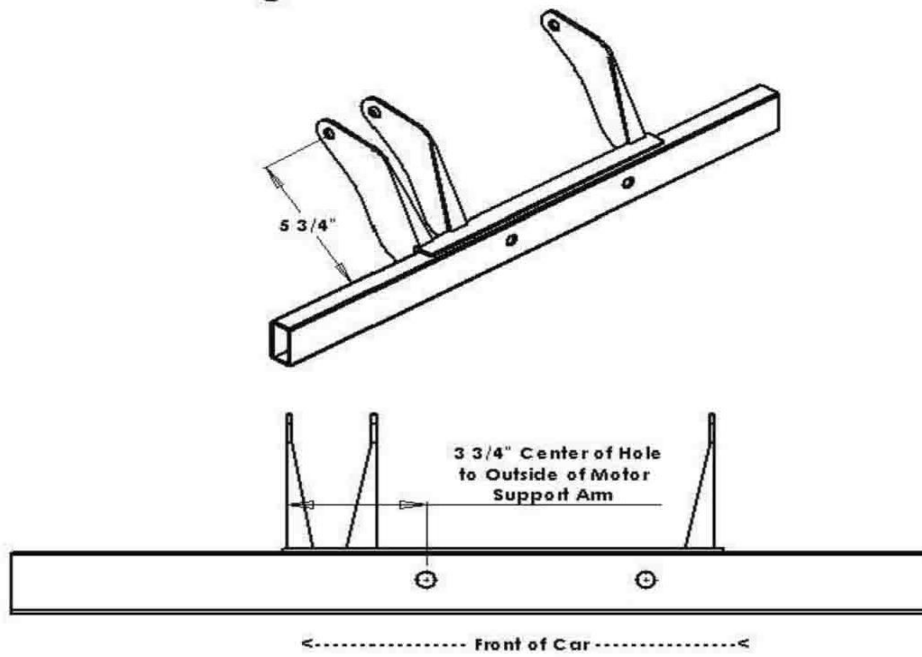

### Legends Battery Box Offset

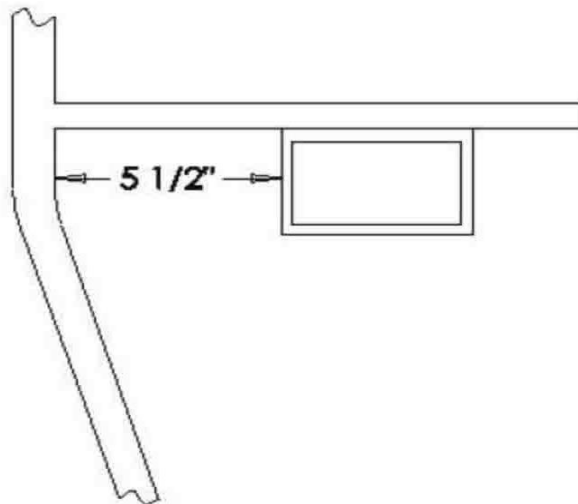

**Note:** The measurement for the battery box offset will be taken at the point closest to the crossmember, from the inside of the frameral to the outside of the battery box.