



2024

African Karting Cup Sporting and Technical Regulations



Version 3

6 February 2024

Ref: 163133

REVIEW AND AMENDMENTS

Amendments and updates to the rules will be recorded in the Amendment Record, detailing the amendments, date applicable and a short summary of amendments.

AMENDMENT RECORD

<i>Modified SSR / ART</i>	<i>Date applicable</i>	<i>Date of Publication</i>	<i>Clarifications</i>
SECTION C - Point 2 a and b	06.02.2024	06.02.2024	Regulation amended
SECTION F – Safety Clothing	06.02.2024	06.02.2024	Regulation amended
ART C Point 7	29.01.2024	29.01.2024	Removed

CONTENTS

SPORTING REGULATIONS	4
SECTION A - ADMINISTRATION	4
SECTION B - ENTRIES AND ELIGIBILITY	4
SECTION C – EVENT FORMAT AND POINTS SCORING	5
SECTION D - PENALTIES	6
SECTION E - COMPETITORS – ENTRANT REQUIREMENTS	15
SECTION F - SAFETY CLOTHING AND PROCEDURES	16
SECTION G - CONDUCT	17
SECTION H - RACING – GENERAL REGULATIONS	18
TECHNICAL REGULATIONS	24
1. FUEL, OIL AND RADIATORS	24
2. DEFINITIONS	24
3. TYRES	24
4. MINIMUM CLASS WEIGHTS PERMITTED	25
5. AXLES, RIMS, REAR TRACK	25
6. SEATS & SUPPORTS	25
7. CHAIN GUARD	26
8. PEDALS	26

9. FUEL TESTING	26
10. TITANIUM	26
11. BODYWORK – GENERAL.....	27
13. ENGINES.....	27
13.1 OKJ ENGINE.....	27
13.2 OK-N ENGINE	27

SPORTING REGULATIONS

SECTION A - ADMINISTRATION

1. The African Karting Cup is administered under the provisions of the General Competition Rules of Motorsport SA (GCRs) and these Standing Supplementary Regulations (SSRs), and other instructions which may from time to time be issued by Motorsport SA (hereinafter referred to as MSA) and the Supplementary Regulations published for each particular kart competition. All the parties concerned (FIA, CIK-FIA, ASNs, Organisers, Promoter, Entrants and circuits) undertake to apply and observe the rules governing the events.
2. Where there is a contradiction between the GCRs and these SSRs the latter shall take precedence.
3. These SSRs may generally only be amended for safety reasons or because of force majeure.

SECTION B - ENTRIES AND ELIGIBILITY

1. The African Karting Cup (AKC) will be open to ASN-selected competitors from all FIA-affiliated ASNs within Africa.
2. The AKC shall be in the form of an *arrive-and-drive* format.
3. The AKC will have the following classes with a maximum of 20 entries per class only:
 - a. OKJ
 - b. OKN
4. The entry fee for the event per competitor will be €500-00 which will provide the following to a competitor depending on the class entered:
 - a. 1 x randomly allocated engine
 - b. 1 x randomly allocated chassis
 - c. 1 x set of race tyres
 - d. 1 x sprocket
 - e. Controlled Fuel
5. The following will be for the competitor's account:
 - a. Accident damage
 - b. Laptimer
 - c. Mechanic
 - d. Practice tyres
 - e. Additional Sprocket
 - f. Tools
 - g. Travel and accommodation costs
6. All competitors must be in possession of an International Karting licence (Grade G for OKJ and Grade E/F for OK-N) issued by their ASN as per the CIK regulations.
7. The following age limits will apply:
 - a. OKJ: Open to drivers from the year of their 11th birthday, to 31 December of the year in which their 14th birthday occurs.
 - b. OK-N: Open to all drivers from the year of their 14th birthday.

SECTION C – EVENT FORMAT AND POINTS SCORING

1. The circuit will be closed for all competitors from Monday of the week preceding the event until Thursday of the week in which the AKC takes place.
2. The two-day event format will comprise:
 - a. Friday:
 1. 6 x free practice sessions of a minimum of 10 minutes duration each.
 2. 1 x qualifying session
 - b. Saturday:
 1. 1x qualifying session
 2. 3 x heats of a minimum distance of 12km each.
 3. 1 x final of a minimum distance of 15km.
4. Qualifying will determine the starting positions for 3 heats only. To clarify, the fastest qualifier will start all 3 heats in pole position and so on.
5. Points will be allocated as follows based on finishing positions in the 3 heats only:
 - 1st - 23,
 - 2nd - 20,
 - 3rd - 18,
 - 4th - 17,
 - 5th - 16,
 -
 - 19th - 2,
 - 20th - 1,
 - and so on.

Non-finisher 5 points less than lowest placed finisher.
6. The competitor with the highest number of points from the 3 heats (added together) will start in pole position in the final and so on.
7. The first-placed competitor in the final in each class will be declared the respective 2024 African Karting Cup winner.
8. The top three competitors in the OK-N class will earn a *ticket* to compete at the 2024 OK-N FIA Karting World Cup, or equivalent at the discretion of the organiser.
9. Winner of OKJ class will win a qualified ticket to the AKC OK-N cup when they come of age.
10. Competitors found guilty of an infringement, resulting in exclusion, will score zero (0) points. Exclusions as a result of a technical infringement will score zero (0) points.
11. In the event of tied competitors not being classified in the last race, then the previous race's finishing order will be taken into account, and so on until the tie is resolved.
12. After the winner has received the chequered flag, any driver who has not completed the full number of provided laps, even if he does not finish the race, will be classified according to the number of laps he has

actually covered, provided he has completed at least two thirds of the race distance (rounded down to the nearest whole number of laps). No kart may be pushed over the finish line.

SECTION D - PENALTIES

1. PENALTY FOR TECHNICAL INFRINGEMENTS

- i. Notwithstanding anything stated to the contrary in MSA's General Competition Rules, (Specifically GCR 176) any contravention of the technical regulations or specifications will result in automatic exclusion from the relevant race (in circumstances where it can reasonably be assumed that the contravention applied to the specific race only) or from the entire event/race meeting (in all other cases).
- ii. Any component and or kart found not to comply with the technical regulations and specifications must be impounded by the relevant officials. The component may be returned to the competitor if the infringement is capable of being rectified (e.g. axle of kart too wide) but only after an admission of guilt form has been filled in, signed by the competitor and submitted to, and accepted by, the Clerk of the Course.
- iii. It is at the discretion of the Clerk of Course to decide whether to return a non-compliant part, in consultation with the TC.
- iv. A competitor removing a part/kart from parc fermé that is deemed to be the subject of a technical infringement, as pronounced by the TC, without having signed an admission of guilt form, will automatically be excluded from the race concerned (if it is clear that the infringement was only in respect of the particular race) or from the entire race meeting (in all other instances). Any such exclusion shall be final, without the prospect of protest or appeal.
- v. In the event of a dispute concerning any item/component/part not covered in the relevant regulations or specification sheets, the Technical Consultant shall be empowered to make a ruling as to whether or not a contravention exists and, if found that one does, to recommend an appropriate penalty other than exclusion for imposition by the Clerk of the Course.

2. PENALTY FOR WEIGHT INFRINGEMENTS

Competitors and/ or karts found to be underweight will be excluded. The lap times set in the heat will also be disregarded for grid positioning for the next race. Any competitor that does not weigh will be excluded. Should a competitor be found to be underweight an admission of guilt form will be signed, with no hearing been held by the COC. The scale official will submit all underweight admission of guilt forms to the COC, for the penalties to be implemented.

3. NOSE CONE

- i. The black flag with the orange disc will NOT be shown to a driver if his nose cone is no longer in the correct position. If an official reports that the nose cone on one or more karts is/was no longer in the correct position when the kart enters the exit lane to the scale/weighing area, in all situations a 5 second time penalty will be imposed automatically on the driver(s) concerned. This penalty cannot be protested.
- ii. Should a driver be found to have tampered with/replaced/realigned or attempted to tamper with/replace/realign the nose cone which was not correctly positioned when entering the exit lane

or after the chequered flag was waved, the correct penalty will apply as per the penalty schedule below. Competitors may not use repaired (e.g. plastic welding, cable ties) nose cones.

- iii. A defective nose cone may allow bumping to go unpunished. If the underside of the nose has worn through at the connection to the vertical front face the nose cone or if any nose cone seam is split open, the nose cone is no longer legal, and the kart should not race. Damage like this renders the nose cone ineffective to the intended design - which is to penalize offenders who bump into their fellow competitors. Repairs are forbidden and if no supplier has any stock of any make of FIA Karting Nose Cone, a repair approved by the TC is acceptable for that event only.
- iv. Photographic evidence submitted **ONLY** by the Nose Cone official and or any MSA official listed in the event SR's, of the nose cone dislodgement will be sent to the Clerk of Course and will be deemed as irrefutable evidence in the issuing of a penalty.
- v. Such penalty will automatically be imposed without the requirement for a hearing as envisaged in GCR 175. The Clerk of the Course may empower a deputy / assistant Clerk of the Course to issue nose cone penalties without same having to receive instruction from the Clerk of the Course for each infringement.
- vi. Notices pertaining to any such infringements will be disseminated via the VNB (Virtual Notice Board)
- vii. Should a competitor's nose cone no longer be in the correct position at the end of Qualifying and/or a race, the penalty applied will be as per the penalty schedule. Notwithstanding the provisions of GCR 175, this decision is non-protetable.

DESSIN TECHNIQUE N° 2d

Installation correcte du «Carénage Avant»

Position correcte / Correct position

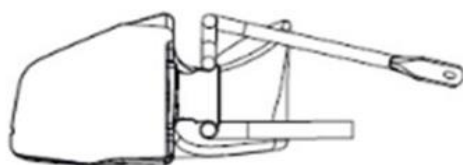

TECHNICAL DRAWING No. 2d

Correct installation of the "Front Fairing"

Position acceptable / Acceptable position

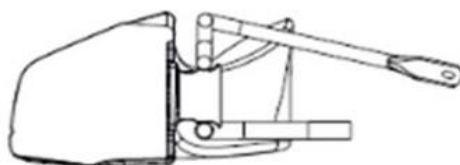

Position non acceptable si une quelconque partie des tubes du
para-chocs avant se trouve dans les zones marquées (A).

Not acceptable position if any part of the tubes of the front
bumper are in the marked areas (A).

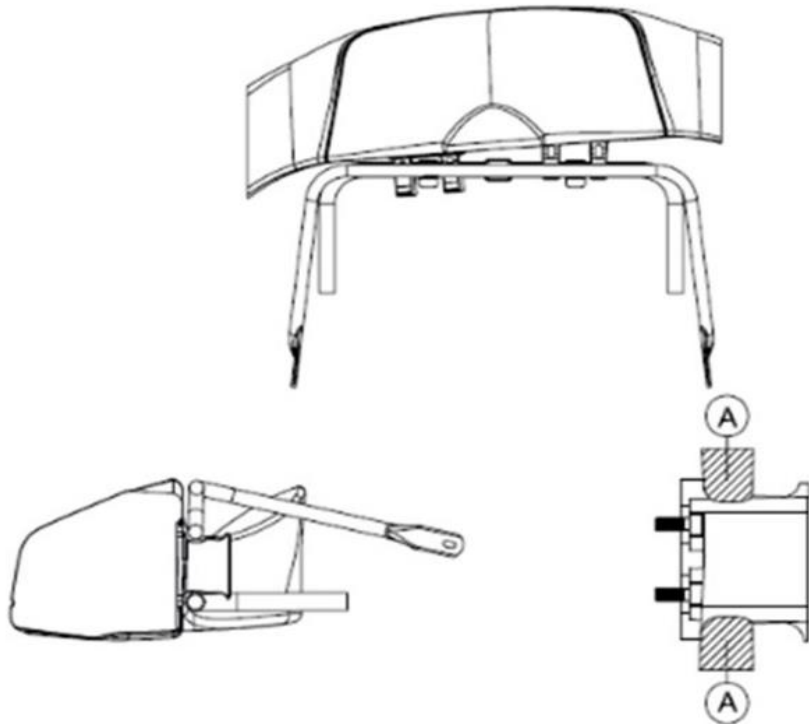

4. PENALTY CATALOGUE

FALSE START (Type A) means Kart 2 leaves the marked corridor during launch phase with at least two tyres before the start has been released. Leaving = the tyres are completely on or outside the corridorline.

PENALTY

3 seconds

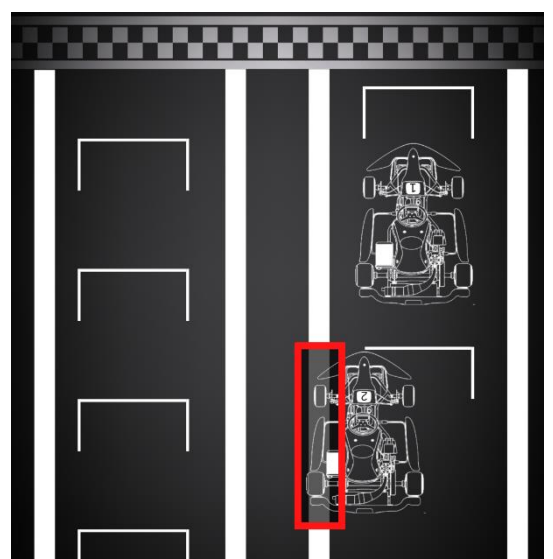

FALSE START (Type B) means Kart 2 leaves the marked corridor during launch phase with at least four tyres before the start has been released. Leaving = the tyres are completely on or outside the corridorline.

PENALTY

10 seconds

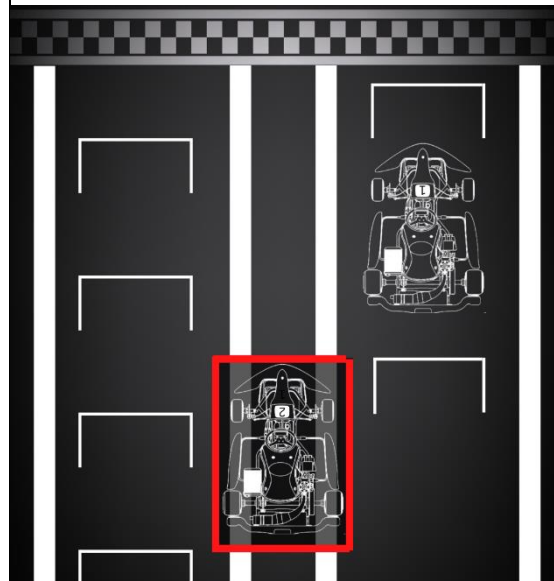

JUMP-START means that Kart 2 accelerates during launch phase leaving Kart 1 behind before start has been released. It is irrelevant if the start will be repeated afterwards.

PENALTY
5 seconds

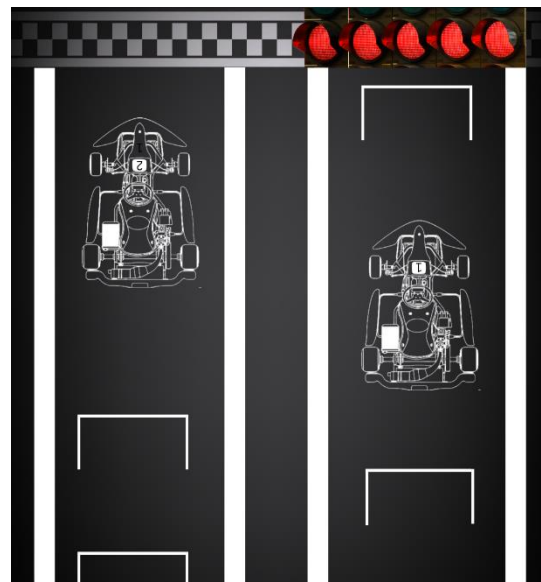

CUT-IN means that Kart 1 constricts the drivable section towards the curve center forcing Kart 2 to leave the drivable section either partial or completely for passing the curve. It is irrelevant if the Karts have touched each other or not. A prerequisite is, however, that Kart 2 must be at least 1/3 (front tyres next to side pod) next to Kart 1.

An advantage is at hand, if (either/or):

- Kart 2 suffers a position loss or drop-out.
- Kart 2 suffers a damage leading to a position loss or retirement within the same lap.

PENALTY
2 positions (No Advantage Gained)
5 positions (Advantage Gained)

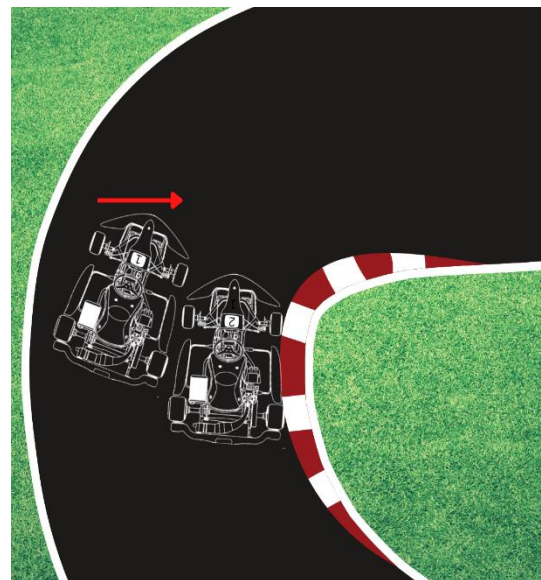

EDGE-INTO means that Kart 2 drives next to Kart 1 (e.g. in order to start an overtaking action) without possessing enough drivable section (including kerbs). It is irrelevant if Kart 2 is completely or partially next to Kart 1 or if Kart 2 is completely or partially off the track.

An advantage is at hand, if (either/or):

- Kart 2 wins a position.
- Kart 1 suffers a position loss or drop-out
- Kart 1 suffers a damage leading to a position loss or retirement within the same lap.

PENALTY

2 positions (No Advantage Gained)

5 positions (Advantage Gained)

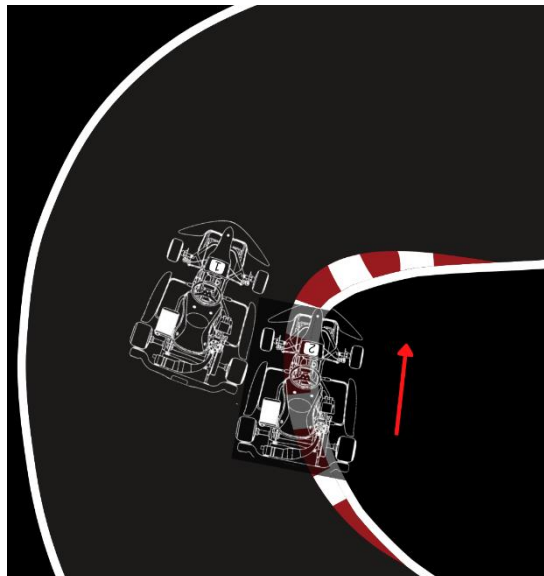

PUSH-OUT means if Kart 1 constricts the drivable section towards the outside line forcing Kart 2 to leave the drivable section either partial or completely.

It is irrelevant if the Karts have touched each other or not.

A prerequisite is, however, that Kart 2 must be at least 1/3 (front tyres next to side pod) next to Kart 1.

An advantage is at hand, if (either/or):

- Kart 1 wins a position.
- Kart 2 suffers a position loss or retirement
- Kart 2 suffers a damage leading in a position loss or retirement on the same lap.

PENALTY

2 positions (No Advantage Gained)

5 positions (Advantage Gained)

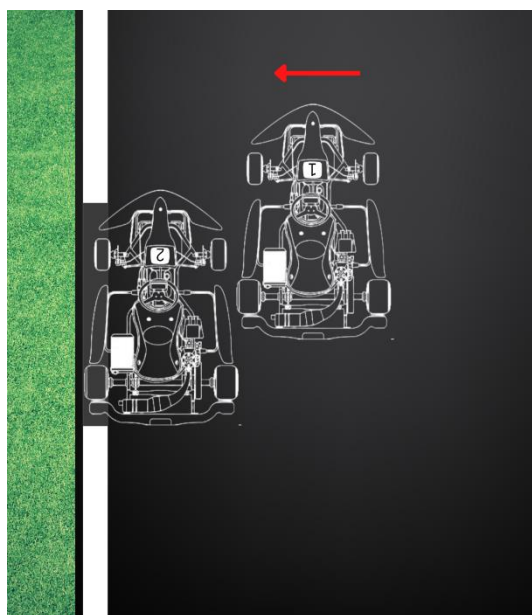

BUMP means that the front of Kart 2 touches the rear of Kart 1.

Neither the reason nor the intensity of the contact is relevant. Only the consequences of the impact are relevant to judge an advantage, not the impact itself.

An advantage is at hand, if (either/or):

- Kart 2 wins a position, and the previous order cannot be restored within the same lap.
- Kart 1 suffers a position loss or retirement
- Kart 1 suffers a damage leading in a position loss or retirement within the same lap.

PENALTY

**Warning (No Advantage Gained)
Black / White flag for Unsportsmanlike behavior**

5 positions (Advantage Gained)

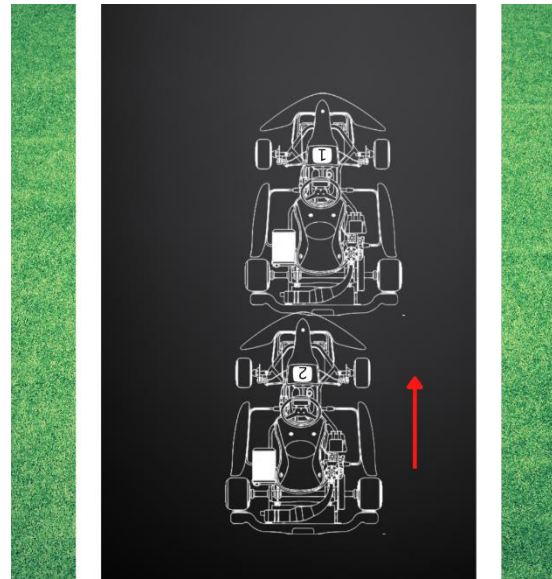

SHORT-CUT means that Kart 2 leaves the track completely and returns to the track at a different section.

It is irrelevant why Kart 2 has left the track.

An advantage is at hand, if (either/or):

- Kart 2 wins a position or gains time which cannot be given back within the same lap.
- Kart 1 or any other is handicapped by the return of Kart 2.
- Kart 1 or any other suffers a position loss or retirement on the same lap by the return of Kart 2.

PENALTY

Warning (No Advantage Gained) Black / White flag for Unsportsmanlike behavior

5 positions (Advantage Gained)

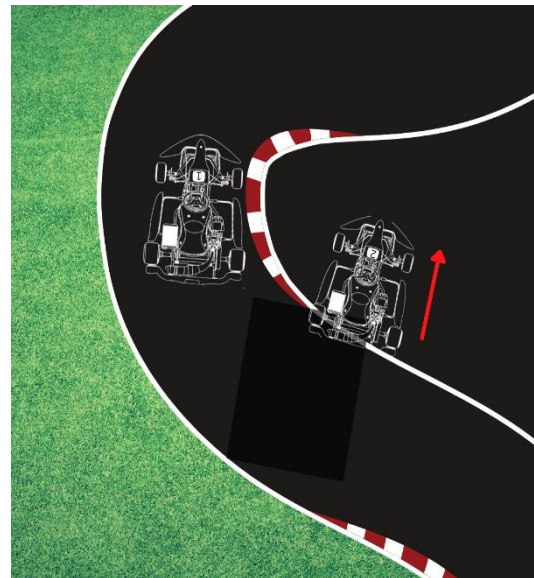

ZIG-ZAG means that Kart 1 changes the driving line more than two times on a straight track section for more than a kart width.

It is irrelevant how far Kart 1 is ahead of Kart 2 or if Kart 2 would have been able to overtake.

An advantage is at hand, if (either/or):

- Kart 1 acts more than once a time this way within the same race.

PENALTY

Warning (No Advantage Gained) Black / White flag for Unsportsmanlike behavior

5 positions (Advantage Gained)

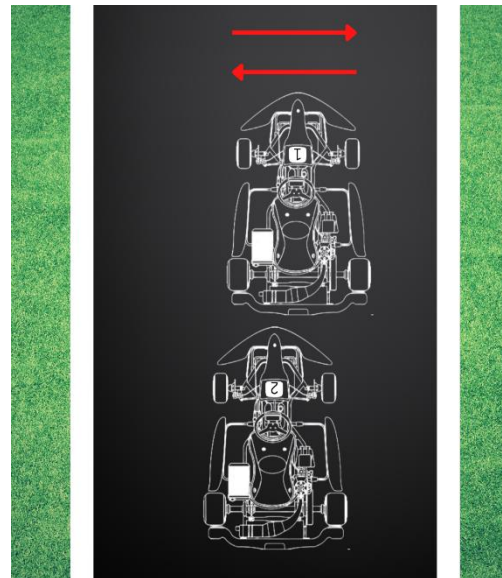

TECHNICAL NON-COMPLIANCE is at hand, if the Kart is not fulfilling the technical regulations in all parts. It is irrelevant, if the technical lack arises before, during or after the race. It is also irrelevant, if the technical lack would have led to an advantage or not. The only relevant thing is the technical condition at the time of examination.

Typical examples for a technical non-compliance are:

- Under-weight
 - Wrong setup (contrary to Class Technical regulations)
 - Wrong fuel, oil, ...
 - Modified parts
- etc.

PENALTY

Exclusion



FORMATION FAULT is at hand, if Kart 2 improves its starting position unforced during the formation lap after having crossed the “red line”
(and before the start has been released).

PENALTY

5 second penalty

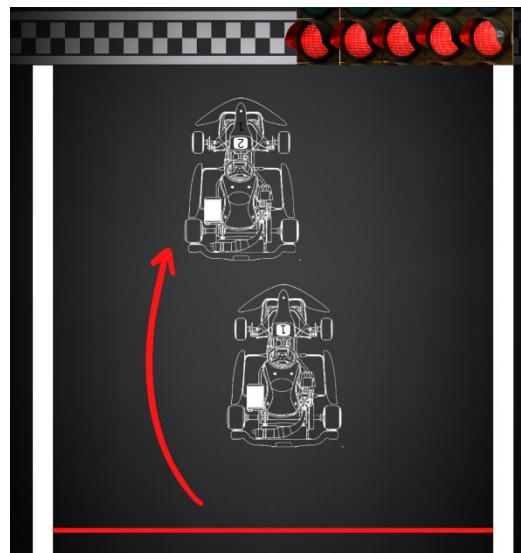

FLAG DISREGARD is at hand, if the driver does not carry out the flag instructions given by either the track personnel or clerk of the course.

It is irrelevant which flag is in question, why the flag has been disregarded or if the violation would have led to an advantage or not.

Typical examples of a flag disregard are:

- Overtaking under yellow flag (see diagram).
 - Continuing the race after receipt of black/orange flag.
- etc.

PENALTY

Race Exclusion

NOTE: This applies to all flags

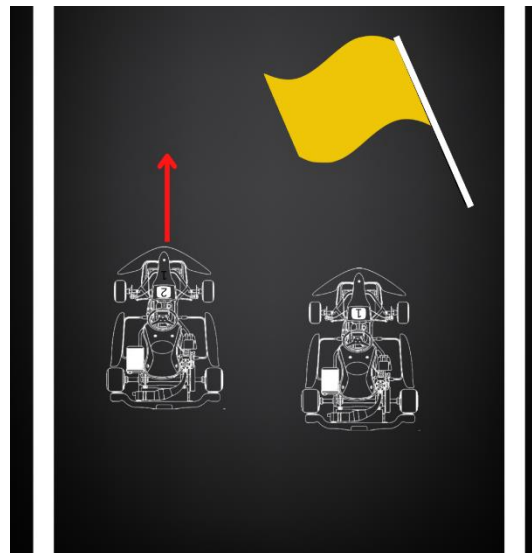

5. ADDITIONAL PENALTY SCHEDULE

Additional penalty scale available to officials

DESCRIPTION		PENALTY
i)	Driving in a manner incompatible with general safety	10 seconds, Race or race meeting exclusion
ii)	Contravention of flag signal - Ignore Technical Flag Twice	Black Flag
iii)	Abusive Language, Behaviour or Assault	Race or race meeting exclusion
iv)	Failure to attend Drivers' Briefing	Fine of R 1 500
v)	Failure to obey an Official of the Meeting	Race or race meeting exclusion
vi)	Technical Non-Compliance Report, vehicle, or component ineligible	Race or race meeting exclusion
vii)	Underweight	Race exclusion
viii)	Failure to report to Scrutineering	Race Meeting exclusion
ix)	Incorrectly positioned Nose Cone - Qualifying practice	Deletion of fastest time
x)	Incorrectly positioned Nose Cone - race	5 Seconds penalty
xi)	Tampering with or reattaching, or attempting to tamper with or reattach the Nose Cone during or after a timed qualifying session or race	Race exclusion from class competed in with a report to MSA for possible further action.

SECTION E - COMPETITORS – ENTRANT REQUIREMENTS

The following regulations are supplementary to the General Competition Rules of MSA.

1. The provisions of GCR 22 notwithstanding, in karting should a parent or court appointed legal guardian not be in a position to act as the entrant for his or her minor child, he or she may nominate another parent/legal guardian whose minor child is taking part in the same event/s or, alternatively, an adult competitor taking part in the same event, to act as his/her entrant by proxy. To be valid, any such proxy nomination must be submitted, in writing and signed by the parent/legal guardian appointing the proxy, to the Race Secretary for the relevant event/s prior to the commencement of competition.
2. An adult competitor may appoint another adult competitor competing in the same event to act as his/her entrant. Subject to what is set out below in order for that appointment to be valid, that appointment must be submitted in writing recording the reasons for the appointment and signed by the adult competitor appointing another adult competitor to act on behalf of his/her behalf to the Race Secretary for the relevant event prior to the commencement of the event.
3. For the purposes of this Regulation, an adult competitor excludes any person/s or body deemed to be a competitor (as envisaged in GCR 19) as a consequence of being an entrant in terms of GCR 22.

4. The Stewards and/or the Clerk of the Course shall be entitled to investigate the reasons why a parent/legal guardian and/or an adult competitor is not in a position to act either for himself/herself or for his/her minor child as an entrant. The Stewards and/or the Clerk of the Course shall in their sole and absolute discretion be entitled to accept and/or reject the appointment of either the third party nominated to act for a minor child or an adult competitor nominated to act for another adult competitor.
5. It is the entrant's responsibility to ensure that all persons concerned by his entry observe all the provisions of the code, the technical regulations, and the sporting regulations.
6. The person having charge of an entered kart during any part of an event is responsible jointly with the entrant and/or separately for ensuring that the provisions are observed.
7. Entrants must ensure that their karts comply with the conditions of conformity and safety throughout the event.
8. The presentation of a kart for scrutineering will be deemed an implicit statement of conformity.
9. Entrants, drivers, assistants, and guests must always wear the appropriate identification credentials which have been provided to them.

SECTION F - SAFETY CLOTHING AND PROCEDURES

Drivers shall wear, both during official and unofficial practice and during all racing, a properly positioned and secured crash helmet, with splinter proof visor in position. In addition, gloves that cover the hands completely, and a protective one-piece race suit must be worn. Boots and socks must be worn adequate to cover and protect the ankles. **The use of an FIA chest guard and neck brace is compulsory. The use of a chest guard is compulsory. Note: an FIA-approved chest guard is highly recommended. The use of a neck brace is recommended.**

1. **SUITS** – All Karting Suits must be CIK homologated.
2. **HELMETS** - All drivers must wear a helmet with efficient and unbreakable protection for the eyes. All helmets must comply with the DOT, SNELL, ECE or CMR specifications approved for the following categories of motorsport, Cars, Motorcycle and Karts. All helmets must have chin protection (Full-face helmet). It is highly recommended that drivers of the age 15 and younger use CMR specification helmets.
NOTE: The use of Helmets 10 years after their date of manufacture is not permitted. All labels and markings indicating specifications and date of manufacture must be clearly visible. Event officials may request a competitor to provide proof that the helmet does comply with requirements as set out in this regulation.
3. Drivers must always secure all loose straps or flaps around the helmet base and neck area, including neck brace and overall straps. If doubt exists with officials as to whether a helmet strap is fastened correctly, then the competitor will receive a black & orange flag. Once the competitor has secured the helmet and /or loose straps then he/she will be allowed to return to the circuit.
4. Entering pits - It is compulsory for all drivers to stop and cut their engines at the entrance to the paddock areas. Failure to observe this rule may result in a fine of R750.00.
5. During both practice (unofficial and official) and racing, drivers intending to leave the track to enter the paddocks or pits must indicate their intention by raising one arm. They must leave the track on the side that will give them an uninterrupted run into the pit or paddock entrance without crossing the path of a following kart.

SECTION G - CONDUCT

- 1.** All persons shall conduct themselves in an orderly manner. Any disorderly conduct or any failure to obey official instructions or any breach of these regulations by entrants, drivers, or their assistants, shall make the entrant concerned liable to a penalty and/or fine. All participants must play within the rules and respect race officials and their decisions.
- 2.** All participants must respect the rights, dignity, and value of their fellow participants regardless of gender, ability, physical appearance, cultural background, or religion. All participants must always encourage and take responsibility for their actions.
- 3.** All participants must ensure their equipment is safe and race worthy, prior to taking part in training, testing or race events. Only approved racewear (e.g.: helmet, gloves, race boots and suit) to be used by the driver, according to the regulations.
- 4.** It is the participants own responsibility to identify and measure his/her own skill level against his/her competitors, and take responsibility for the risks associated with training, testing and or racing. It should be noted that a basic level of competence is required.
- 5.** It is the participant's responsibility to declare, prior to any participation in training, testing, or racing, of any medical condition or medication required that may be relevant in the event of an emergency.
- 6.** All participants are required to display courtesy and etiquette to other members and participants in training, testing and race events. Any disputes or problems that may arise during an event must be addressed in a respectful manner, to the correct person (official) at the event.
- 7.** The safety of children within the sport is a priority. Knowledge of the code of ethics surrounding care of children in sports will be promoted and encouraged. It is the participant's own responsibility to ensure the safety of children at training, testing, or racing events.
- 8.** When taking part in any event, it is the responsibility of the driver to take the time to read and fully understand the posted rules, regulations and conditions for said event prior to start time, thus eliminating unnecessary delays at the beginning of the event. Requests for clarification of these rules, regulations, or conditions, should be asked in the drivers meeting held before each event.
- 9.** All participants must have respect for the environment and the surrounding inhabitants. Responsibility must be taken to reduce excessive noise and keep all areas that are used as clean and pollution free as possible.
- 10.** All participants must respect that drugs and alcohol are strictly prohibited at training, testing and races. It is an offence and will not be tolerated. Offenders will be excluded from the event and face further disciplinary action.
- 11.** Any abusive comments on social media (Facebook, Twitter etc.) between teams, competitors, officials, organizers, will be held responsible and liable for their actions.
- 12.** If the offence occurs during a race, the kart and driver concerned may be excluded from the race, or entire event and/or a penalty and/or a fine may be imposed. Failure to report at a specified time shall be a breach of the regulations and may be subject to a penalty and/or a fine.
- 13.** Any proceeding, derogatory action, or interference with or against a race official by entrants, drivers, or their assistants shall be considered a breach of GCR 172 (iv) and shall make the entrant liable to a penalty and/or a fine. (Refer to GCR 121 for the definition of responsibility).

14. Abuse of officials – refer GCR 172 (x).

SECTION H - RACING – GENERAL REGULATIONS

1. POST RACE SCRUTINY

- i. After either a race or an event, the Clerk of the Course may instruct that karts shall be placed in possession of the promoters/organisers for examination by the Scrutineers / Technical Consultants to determine if they comply with the regulations.
- ii. Any kart failing to comply shall be dealt with in terms of these regulations. Refusal to submit a kart for scrutiny as directed shall result in automatic exclusion from the entire event and further disciplinary action. Any part found not to comply with the regulations, and which is incapable of being brought back into specification in a permitted manner, will be confiscated by the organisers to prevent its continued use.

2. DESIGNATED REVVING AREA

To avoid excessive noise and exhaust emissions revving the engine in the servicing park is not allowed (except a short function test – 5 seconds maximum) Competitors are advised that organizers and officials will now strictly enforce this regulation and to accommodate those wishing to “REV” or warm up their engines the following points will apply: a,

- i. “Servicing park” is defined as any area or surrounding the pits, access roads, parc ferme’ or pre-race grid.
- ii. Each circuit will have a defined “REVVING” area, and this will be the only place where tests of longer than 5 (five) seconds are permitted. This area will generally be in the pre-race area of the circuit.
- iii. A fine of R500.00 for a first offence will be imposed for any breach of these regulations. Any subsequent transgressions will be penalised at the discretion of the race officials.
- iv. A statement from any signed on official of the event is the only evidence required for the imposition of a penalty.

3. WITHDRAWAL FROM AN EVENT OR RACE

Refer GCR 110

4. FIRE EXTINGUISHERS

Each competitor shall be required to present a dry powder fire extinguisher at pre-race scrutiny. The extinguisher must be of at least 1,5kg capacity and be marked in a permanent fashion with the competitor’s name and competition number. It must bear evidence of having been serviced within the previous 12 months.

5. FLAGS

Flag signals will be as per MSA Appendix H and in addition:

- i. A green flag with yellow chevron will be used to signal a false start. This flag will be situated at the marshal post at Turn 1 after the start. It will be waved at the instruction of the Chief Marshal.
- ii. A green flag may also be used, if necessary, to signal the start of warm up laps, or the start of practice sessions by order of the Clerk of the Course. It is not obligatory that this flag will be displayed after showing the yellow flag to indicate the track is clear of any dangerous situation, provided the supplementary regulations state that the green flag will not be displayed in such situations.

- iii. A blue flag with red diagonal crosses used in conjunction with a signal board displaying a competitor's number, will signify that the competitor must stop as he/she has been lapped or is about to be lapped.

6. VEHICLES - GENERAL

- i. All karts must satisfy the Scrutineers and Technical Consultant of the meeting as to their suitability for racing, considering all details of their design and construction. In addition, it must be evident, both from a static examination and from its behaviour on the track, that a kart will present no hazard to the driver or to other competitors or to spectators. Checks may be carried out at any time to ensure that only permitted chassis are being raced.
- ii. Karts shall be fitted with adequate brakes on at least both rear wheels. Tyres of an industrial type shall not be used. In addition, the handling and steering characteristics of all karts shall be such, in relation to the course, that no hazard is created.
- iii. In the interest of safety, before a kart proceeds onto the track for timed laps or races, a check shall be made that it has been passed by the Scrutineers.
- iv. Only the officially nominated driver shall drive a kart on the track during pre-race practice and racing, except with the specific permission of the Clerk of the Course.
- v. Only CIK homologated chassis will be permitted.

7. RACING NUMBERS

- i. Each kart shall be identified prior to scrutineering by opaque flexible plastic number plates affixed to the kart itself and facing front and to the rear. Black numbers displayed on yellow backing only will be allowed and with a minimum dimension of 14cm (140mm)
- ii. The numbers must be standard font "ARIAL" and in an unbroken colour without borders, edging or shadow. For TV coverage, marketing and timekeeping purposes, all race numbers must be bold upright (no italics) ARIAL font. Script type numbers are not permitted. Neither neon-coloured numbers and or backgrounds are permitted.
- iii. Competition numbers must be present and legible on the side pods in the same upright bold fonts as above. For TV & marketing, the recommended size for these side numbers is 80mm.
- iv. All racing numbers shall be allocated by and be obtained from MSA on a first come first served basis.

8. ROLLING STARTS

- i. On display of the green flag indicating that karts are under starter's orders, the karts will leave the pre-race paddock and proceed in two parallel rows in grid order directly to the 90 metre steady speed point (see below) or complete a lap or part thereof as instructed by the Clerk of the Course depending upon the nature of the circuit or the size of the field.
- ii. No further karts will be allowed out of the pre-race paddock onto the circuit once the start signal has been given and the race has begun.
- iii. A steady speed point must be indicated by a RED line and/or markers on either side of the track at a suitable point (within the ambits of the circuit). But not less than 90 meters before the start line, and when the pole position driver reaches this point, he must set and maintain a reasonable and constant speed slow enough to allow the field to form and bunch up and the driver in No 2 position must at this stage without delay position himself level with the pole driver.

- iv. The rest of the field must then bunch up in their allocated positions behind the two leading drivers, in two parallel lines. A driver, who is unable to take up his correct grid position prior to the field reaching the 90 meters' steady point, must take up position at the rear of the field.
- v. The No 2 driver must maintain position level or slightly behind the pole driver as they approach the start line. At any point between the 25-meter line and the start line, when the two leading karts are level, or the pole man is slightly ahead and the majority of the field (generally the first 10 karts) is in position, well bunched up and in two parallel lines, the starter may give the starting signal. Until the signal to start is given the entire field will remain in grid order one behind the other and it is forbidden to move either to the left or the right or leave more than one kart length behind the kart in front.
- vi. Should the Starter or the Clerk of the Course not be satisfied with the disposition of the field as the leading karts approach the start line, it may be indicated that the field must complete another warm up lap, or a false start may be notified to the drivers by means of showing the false start flag (green with yellow chevron).
- vii. Drivers will then proceed round the circuit and repeat the starting procedure. Should the start signal have been given and the race has in fact begun, then any competitor guilty of a starting offence may be penalised and will be notified accordingly after the race.
- viii. The onus is on each competitor to ensure that he/she complies with the starting procedure. In the event of the pole driver not being able to take up his correct position, the No 2 driver will be responsible for setting the pace from the Red 90-meter steady point. If either of the front row grid positions are vacant as the field approaches the start line, then the starter may start the race based on the position of the remaining front row kart(s) alone.
- ix. Note: Any penalty imposed as a result of the above, must be advised to the competitor after completion of the race or heat and must be deducted immediately from the driver's accumulated points for the day following a hearing.

9. SIGNAL TO START A RACE

- i. A race shall be started by the lowering of the MSA flag or alternatively by the extinguishing of the red light/s. In the latter case, a red light/s must be mounted directly above the circuit and must be visible from any point on the starting grid.
- ii. Illumination of the red light will correspond to the raising of the start flag, being followed by extinguishing of the light/s to start the race. In the use of flag starts, the starter may be positioned beside the track but may not start the race from any position upon the tarmac of the circuit.
- iii. It is obligatory to state in the supplementary regulations if lights are to be used. In the case of a false start, the Clerk of the Course may have the field return to the pre-race paddock and penalise the guilty driver accordingly.
- iv. Should the Clerk of the Course allow the field to reform for another lap and a starting offence is again committed, the race will continue, and the guilty party shall be penalised accordingly after the end of the race. Should a penalty be imposed, that penalty will be a place penalty of 5 places for the first offence, then 8 places for the second offence and then exclusion for the third offence.
- v. Any penalty imposed as a result of the above must be advised to the competitor with a hearing after completion of the race or heat and the race results must be immediately amended to allow the driver's accumulated points for the day to be calculated correctly.

10. SIGNAL TO FINISH THE RACE

- i. It shall be obligatory for the chequered flag to be shown after the last lap board. After receiving the end of the race (or practice) signal, which shall be the displaying of the chequered flag, each driver shall continue at a reduced speed to the paddock entrance.
- ii. If, during a race, the chequered flag is inadvertently displayed before the race is scheduled to end (in terms of the SR's or as amended), the race will nevertheless be deemed to have ended.
- iii. If, during a race, the chequered flag is inadvertently displayed after the race is scheduled to end, the race will nevertheless be deemed to have ended when it was due to end.

11. REFUELING

Refuelling during a race is forbidden, unless permitted by the Supplementary Regulations. Whenever a kart is refuelled at the pits, the engine shall be stopped throughout the refuelling operation, and the driver shall vacate his kart. No entrant shall have any one container in the pits holding more than 25 litres of fuel.

12. STOPPING THE RACE

- i. Should it be deemed necessary to stop the race due to an accident on the grounds of safety or for any other reason, the RED FLAG shall be shown by the Clerk of the Course and all flag Marshals shall show red flags to indicate the race has been stopped.
- ii. All drivers will immediately stop racing and continue slowly to the start line, being prepared to stop at any point if requested to do so by an official. On reaching the start line, the competitors shall be required to stop. The results will be formulated as follows:
- iii. Should less than two (2) laps have been completed the race shall be re-run and the first start declared null and void. Only the original drivers will be entitled to take part in the restart, and they will take up their original start positions. The restart time will be at the discretion of the Clerk of the Course.
- iv. Should the race be stopped between laps three (3) and 67% of the total race distance, the race will be restarted based on the finishing order of drivers the lap preceding the stopping. The restart time, if delayed, will be at the discretion of the Clerk of the Course.
- v. Should 67% have been completed it shall be deemed a race and the result will be the finishing order at the end of the lap preceding the stopping.

13. TELEMETRY/DATA LOGGING/RADIO COMMUNICATION

Any form of telemetry or radio communication with the kart or driver, while they are in motion on the track, is prohibited, during official practice, qualifying and races. However, data logging for the purpose of later downloading as specified in the regulations only is permitted.

14. ON BOARD CAMERAS

- i. Recording devices (Go-Pro's) may only be mounted with the standard brackets (as supplied with the unit) to the kart's plastic side pods, nose cone and rear bumper or bib and on top of the radiator. No additional mounting extension between the kart and the recording device is permitted.
- ii. A maximum of two recording devices is allowed per kart. It is NOT permitted to mount any device on the outside of helmet.
- iii. Ensure these are adequately and securely fitted to their karts for inspection at scrutineering and at any time during an event.
- iv. Declare their intention to use a camera on their entry form.

- v. Make available all camera footage to officials on demand.

15. WEIGHING SCALE

- i. The weight of the karts shall be adjudged as they crossed the finish line at the end of the practice session or race.
- ii. It is compulsory after qualifying and after each race for all drivers and their karts in all classes to be weighed prior to entering the Parc ferme. The penalty for being underweight is exclusion.
- iii. Scale of the day will be the instrument to be used. The displayed weight is the only number considered – no tolerance or latitude is to be granted by scale attendants.
- iv. Karts MAY NEVER be driven onto the scale and must always be pushed.
- v. A kart will only be weighed once, and the weight recorded accordingly. Should a competitor be under weight, the kart and driver in question will be asked to stand in a quarantined area with no outside interference. Failure to comply with this requirement will result in exclusion. The competitor will be given the opportunity to weigh again twice more, after all other karts have been weighed.
- vi. If a component falls of a kart e.g. Side Pod, rear bumper etc. the driver or official may retrieve the part as long as it is safe to do so prior to proceeding to the scale. If the driver does not retrieve the item prior to going to the scales the weight of the kart will be taken as is and recorded as such.

16. RECOVERY

In case of a breakdown no outside assistance will be allowed except by the designated recovery vehicle.

17. OUTSIDE ASSISTANCE

- i. No driver may receive outside help from any person other than a marshal or race official on the track once the karts have left the pre-start grid for the start of a race. Drivers may, however, during the race, enter the pits by the proper method, weigh the kart, receive assistance in the pits and then re-join the race.
- ii. The only exceptions to the rule regarding assistance on the track are:
 - Marshals may assist drivers who have come to a stop to place a kart off the circuit to avoid obstructing other competitors.
 - The starting of engines or pushing of karts is only permitted by the driver concerned when it is deemed safe.
- iii. From the commencement of the official qualifying practice only authorized officials are allowed on the track. The penalty for receiving outside assistance, whether the assistance is solicited or not, unless it is an authorized race official, is automatic exclusion from that race or qualifying.
- iv. Where a circuit has provision for a demarcated area for repairs to karts which does not require karts to cross the scale, competitors may make use of this area DURING RACING ONLY without the necessity of first crossing the scale. The location of the said demarcated area must be made known to competitors at drivers briefing and karts entering this area for repairs must come to a complete standstill prior to returning to the race circuit.

18. INCIDENT REPORTS

- i. Completion of this form within 30 minutes of observing an incident serves to bring an issue to the attention of the senior race officials at an event.
- ii. It shall not replace a formal protest and the race officials shall not be obliged to act on its contents.
- iii. Forms will not be accepted after 30 minutes of the incident occurring.
- iv. Any competitor who considers himself/herself sufficiently aggrieved, and requires an issue to be formally investigated, is advised to rather lodge a formal protest/appeal as per the relevant GCR's within the stipulated time limits.

19. PROTESTS AND APPEALS

- i. Refer to Part IX and X of the GCRs.
- ii. Where a formal appeal (following a protest) arises as the result of exclusion in terms of a contravention of the technical regulations and specifications, the part/s under dispute will be impounded by the relevant officials, sealed and submitted to MSA Head Office.
- iii. Should notice of intention to appeal not have been timeously lodged in terms of the regulations, and the part/s are therefore not impounded, late acceptance of such appeal shall not be considered or granted.

TECHNICAL REGULATIONS

1. FUEL, OIL AND RADIATORS

- a. Where the SR's for an event specify the fuel to be used, the name of the filling station and pump number will be the only permissible fuel for the event in question.
- b. The organizers have the right to undertake fuel testing by using a FT64 Digitron fuel meter.
- c. Only the specified brand of oil and at the specified ratios may be used and this may not be tampered with in any way.
- d. The promotor will nominate the oils in the event SR's. These will be the only fuel/oils permitted for the event.
- e. Overflow bottles are mandatory for fuel tanks and radiators (if applicable).

2. DEFINITIONS

- a. Chassis – Complete kart as supplied from the registered importer excluding the engine. The only chassis permitted are as per the FIA homologation. Chassis is to be raced as supplied by the OEM.
- b. Engine – Complete power unit as supplied by the importer including exhaust, carburettor, air box, battery, battery box and wiring harness (as applicable).

3. TYRES

- a. The only tyres allowed to be used are Levanto tyres.
- b. One set of new Slick tyres to be used from timed qualifying practice until the last and final race of the competition.
- c. In the case of the race being declared a wet race the competitor is entitled to used 1 set of Wet tyres that has been scanned by the Organizers. Tyres may be used or new.
- d. Only tyres issued by the Promoter/Importer will be permitted for the race.
- e. The organisers must arrange for each competitor's tyres to be marked with his/her racing number and class when exiting the circuit after qualifying, where a barcode scanning system is not in place. The marked (scanned) tyres and/or rims may be impounded by the organisers and re-issued on the day of the race if originally issued prior to race day.
- f. Both dry & wet weather tyres must be identified prior to being used. Checks on identified tyres may be made at any time throughout an event and any competitor found using any tyre, which has not been identified for the event will be excluded from the prior races or qualifying races. Exchanging of tyres between competitors is forbidden and the penalty will be the same as above. The only rain tyre which may be used are Bridgestone's.
- g. It is prohibited to use any chemical treatment, or other means, to artificially enhance the performance of tyres used during official practice or racing. The organisers reserve the right to replace one or more of any competitor's tyres, with a substitute tyre of similar wear, should they believe such action to be warranted. Should a tyre be worn to the extent that it is no longer safe for use, the Clerk of the Course in consultation with the TC may require such a competitor to withdraw from further participation in the event so affected.

- h. The only substance that may be used to inflate tyres is normal air (compressed or otherwise). Race organisers shall have the right to require competitors to deflate their tyres on request and re-inflate them under supervision using normal air. The use of any tyre inflation substance other than normal air and/or the failure to respond to a request to deflate/re-inflate tyres as above shall be deemed a contravention of the technical regulations and shall be dealt with accordingly.
- i. Tyres may not be deflated after the completion of qualifying or race until the kart has left Parc Ferme. The use of any sort of any artificial heating device to pre-heat tyres, or tyre treatment, including the use of heat guns is strictly forbidden for removal of access rubber. The organizers reserve the right to replace one or more of any competitor's tyres, with a substitute tyre, should they believe such action to be warranted, with the consent and agreement of the Technical Consultant Tyres allowed per class:

Class	Slick	Wet
OKJ/ OK-N	LeVanto KRT	Bridgestone YNP

4. MINIMUM CLASS WEIGHTS PERMITTED

- a. OKJ 145kg
- b. OK-N 155kg
- c. The mass shall mean, the minimum mass permitted at all times, including during qualifying, and will include the mass of the driver equipped for racing with helmet, visor or goggles, shoes, gloves and protective clothing. Any ballast carried in order to meet the minimum mass prescribed must be firmly fixed to the satisfaction of the scrutineers only to the chassis or seat. For any ballast weight of up to 2kg, attachment must be by a minimum of one bolt with a minimum size of M6 or permanent fixings, with an additional bolt or fixing for every 4kg or part thereof. Cable ties are NOT allowed.

5. AXLES, RIMS, REAR TRACK

The rear axle as well as the rims used on the chassis do not have to come from the same manufacturer as the chassis itself. The minimum axle wall thickness applies except where keys are fitted. The maximum diameter of rims shall not exceed 5 inches (126mm) the maximum rear width is measured to the outer-most face of the rims or tyres, whichever is the greater. The following is applicable to the classes:

Parameter	OKJ/OK-N
Axle OD	50mm MAX
Axle wall	2.0mm MIN
Axle length	N/A
Axle mass	N/A
Front rim width	13.5cm MAX
Rear rim width	21.5cm MAX
Rear track	1400mm MAX

6. SEATS & SUPPORTS

- a. The kart seat must be rigidly located on the chassis. It must be so designed that the driver is securely located to resist movement when cornering or braking. It must be secure, provide the driver with adequate protection and not be cracked or damaged in such a way as to pinch or lacerate or endanger a driver in any way. Seats supports MUST be mounted by using nuts, bolts,

and a metal or aluminium washer with a minimum diameter of 40mm and 1,5mm thickness to eliminate break through. The lower seat bolts may be loosened in the event of rain.

- b. All seat supports and stays must be bolted or welded at each end. If they are not used, these seat supports and stays must be removed from the chassis frame and seat.

7. CHAIN GUARD

- a. Each competitor will receive one free sprocket. A chain guard is compulsory and must be an effective protection over the top and both sides of the exposed chain and sprocket and extend at least to the lower plane of the rear axle down a line at least level with the centre of both front and rear sprockets. Where engines are fitted with side-mounted carburetors adjoining the front sprocket, a guard must be fitted to prevent the driver's fingers becoming entrapped in the chain.
- b. If a complete chain guard covering the chain and sprockets is used, the chain guard homologated with the engine may be dismantled. In gearbox classes, the chain guard must cover the sprocket and the crown wheel down to the centre of the crown wheel axis.

8. PEDALS

The brake pedal MUST have a double linkage to the master cylinder. The accelerator pedal MUST be equipped with a return spring, and pedal extenders and footrest are allowed.

9. FUEL TESTING

- a. The test instrument will be the Digatron FT64 which must be clearly identified by a serial number or identifying mark and will be the only instrument of the day to be used. Only MSA approved Fuel TC's may perform fuel testing.
- b. The only calibration on the instrument of the day will be the reading from the mixed reference sample fuel that is kept by the fuel TC.
- c. A clearly marked reference sample of every mix ratio (fuel: oil) will be kept by the fuel TC or COC.
- d. The difference in reading between the reference sample that is applicable for each class and competitor fuel reading may not be more or less than 2. This value may be changed by the Fuel TC of the event before qualifying. Fuel testing can be done at any time during the event.
- e. The temperature difference may not be more than 2 degrees Fahrenheit. If the temperature is not within the limits, the fuel tank of the competitor must be impounded and sealed, the competitor's fuel temperature will be allowed to equalize to the reference sample and a new reading obtained no later than 30 minutes before publication of final results.
- f. The minimum amount of fuel in the tank at any time may not be less than 300ml. The fuel may be decanted into a suitable container for the necessary testing to be done.
- g. It is the responsibility of the competitor to be present at all times when readings of the fuel are done and to check with the fuel TC that the fuel used by competitor is within the set parameters.
- h. The COC or Fuel TC may at any time have competitor's fuel replaced with organiser's fuel.
- i. A penalty of exclusion will apply for any infringements of the above and is not protestable.

10. TITANIUM

The use of titanium for any part of a kart is forbidden.

11. BODYWORK – GENERAL

- a. Nose cones may NOT have additional fastenings or securing for example, plastic zip ties, other than as stated below. In the interest of safety, it is permitted to secure the nose cone clamps with a single loose cable tie as pictured below to the upper bumper bar.



- b. In the event of loss of the front fairing (nose cone) during a race, the competitor must pit within (2) laps to have the fairing replaced. Failure to do so will result in the exclusion.

13. ENGINES

13.1 OKJ ENGINE

- a. A pool engine system will be put in place for the event. Pool engines are non protestable.
- b. When engines are swapped, this will include engine, exhaust, carburetor, air box and throttle inner cable.
- c. No type or form of modifications/adjustments is allowed to the engine or any other parts which include the fuel supply, carburetor, ignition etc.
- d. No break is allowed in the fuel line between the tank to the fuel pump and pump to the carburetor other than for the fitting of a fuel filter.
- e. No exhaust or cylinder temperature measuring devices are allowed to be used during competition. A water temperature sensor is compulsory.
- f. During the event, competitors may be requested to swap engines from start of official practice. Competitors will generally use a minimum of two pool engines during a race weekend. It must be noted that the amount of engine swaps/changes for an event is not limited to two and might be more at sole discretion of the controllers. The order in which the engine swap/s takes place will be completely random and is determined and published before start of timed practice.

13.2 OK-N ENGINE

- a. A pool engine system will be put in place for the event. Pool engines are non protestable.
- b. When engines are swapped, this will include engine, exhaust, carburetor, air box and throttle inner cable.
- c. No type or form of modifications/adjustments is allowed to the engine or any other parts which include the fuel supply, carburetor, ignition etc.
- d. No break is allowed in the fuel line between the tank to the fuel pump and pump to the carburetor other than for the fitting of a fuel filter.
- e. No exhaust or cylinder temperature measuring devices are allowed to be used during competition. A water temperature sensor is compulsory.
- f. During the event, competitors may be requested to swap engines from start of official practice. Competitors will generally use a minimum of two pool engines during a race weekend. It must be noted that the amount of engine swaps/changes for an event is not limited to two and might be

more at sole discretion of the controllers. The order in which the engine swap/s takes place will be completely random and is determined and published before start of timed practice.