



MINI ROK

2024 Mini ROK Carburettor Specification

PHBG 18BS CARBURETTOR SPECIFICATIONS:

Note: Please note that there have been **NO** changes to the carburetor specifications. This document is used to clarify the Standard homologated carburetor and jets.

No machining or drilling of jets is allowed on the carburetor and its internal parts. The carburetor must remain standard as supplied by the Vortex Rok Importer.

The importer / Technical Consultant also has the right to supplier competitors with new jets should it be required.

This is a working document and will be updated as and when required. The responsibility is on the competitor to check that the carb meets the required specification.

Carburetor Specifications for all South African 60cc Mini Rok classes for 2024 until further notice.

CARBURETTOR DELL'ORTO PHBG 18 BS

1. Throttle Valve Slide= 40
2. Mixture Needle= W23
3. Atomizer / Emulsion Tube (**Mini Rok**)= 266 AN
4. Reserved
5. Idle Diffuser= 50
6. Starter Jet= 60
7. Main Jet= Free
8. Needle & Seat
9. Float= 4g
10. Air Screw
18. Surge Plate (Pg. 2)= Compulsory
- A. Other Dimensions
- B. Other Dimensions
- C. Emulsion Tube / Insert Height dimensions (MINI ROK)
- D. General



Measuring of components:

Some components will be measured with aid of a Vernier.

Measurement of Diameters applicable to the entire document:

Diameters of jets / holes will be measured using GO / NO GO gauges.

Special Tools / Drill bits will be used to measure some holes and used as GO / NO GO gauges.

These gauges can be verified with use of a 0-25mm micrometer.

<**GO**= Gauge will be required to slide into the required hole.

<**NO GO**= Gauges must not be able to slide into the required hole.

Should a part be found to be out of spec, it will be impounded for further measurement if required.

Attention: ALL THE ENGINE PARTS MUST BE ORIGINAL BY VORTEX ROK.

Neither engines nor accessories can be modified. By this we mean any shape, content or function changes which may differ from what previously conceived. Furthermore this includes any addition and /or removal of material and /or parts from the engine set-up package unless provided by this regulation.





MINI ROK

Illustration Only

CARBURATORE DELL'ORTO PHBG 18 BS E COMPONENTI
CARBURETTOR DELL'ORTO PHBG 18 BS AND COMPONENTS

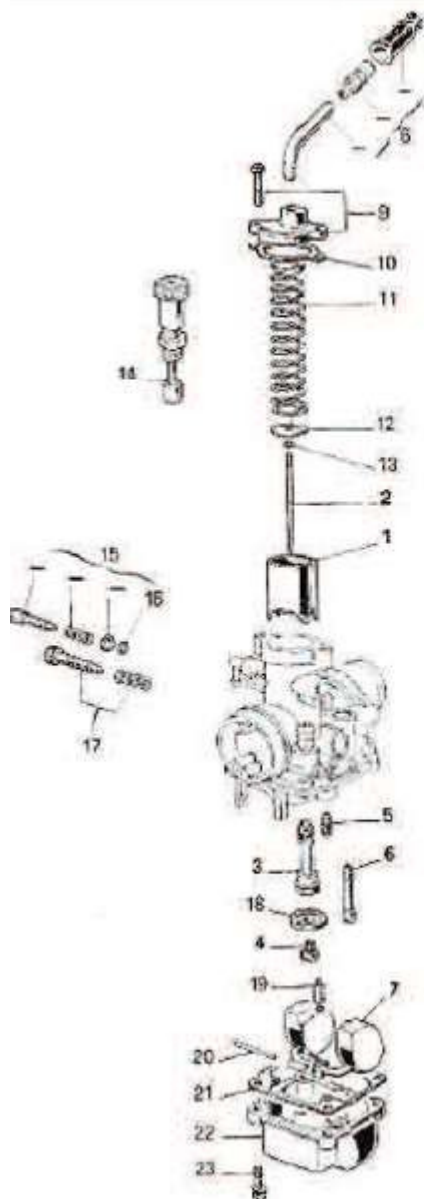

1. VALVOLA GAS
2. SPILLO CONICO
3. POLVERIZZATORE
4. GETTO MASSIMO
5. GETTO MINIMO
6. GETTO AVVIAMENTO
7. GALLEGGIANTE
8. KIT TUBETTO 90°
9. KIT COPERCHIO CAMERA MISCELA
10. GUARNIZIONE COPERCHIO CAMERA MISCELA
11. MOLLA RICHIAMO VALVOLA GAS
12. PIASTRINA RITEGNO FERMAGLIO SPILLO CONICO
13. FERMAGLIO SPILLO CONICO
14. DISPOSITIVO AVVIAMENTO
15. KIT VITE REGOLAZIONE MISCELA MINIMO
16. GUARNIZIONE VITE REGOLAZIONE MISCELA MINIMO
17. KIT VITE REGOLAZIONE VALVOLA GAS
18. FONDELLO
19. SPILLO CHIUSURA BENZINA
20. PERNO GALLEGGIANTE
21. GUARNIZIONE VASCHETTA
22. VASCHETTA
23. VITE FISSAGGIO VASCHETTA

0

Attention: ALL THE ENGINE PARTS MUST BE ORIGINAL BY VORTEX ROK.

Neither engines nor accessories can be modified. By this we mean any shape, content or function changes which may differ from what previously conceived. Furthermore this includes any addition and /or removal of material and /or parts from the engine set-up package unless provided by this regulation.





MINI ROK

1. Slide (40)

- 1.1 Length of Slide
Spec: 27.50mm \pm 0.15mm
- 1.2 Length of Cut Away to the top of the Slide
Length of Slide
Spec: 23mm \pm 0.25mm
- 1.3 Length of Cut Away to the top of the Slide
Length of Slide
Spec: 23.4mm \pm 0.15mm

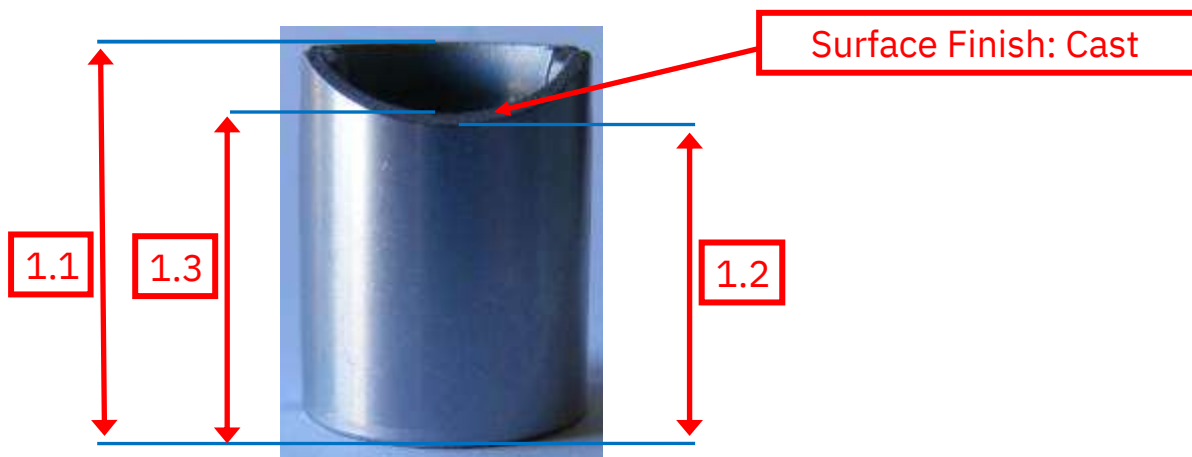

2. Needle Mini Rok (W 23) - (incl. Clip position for Kid Rok).



Needle clip position <2= for Kid Rok

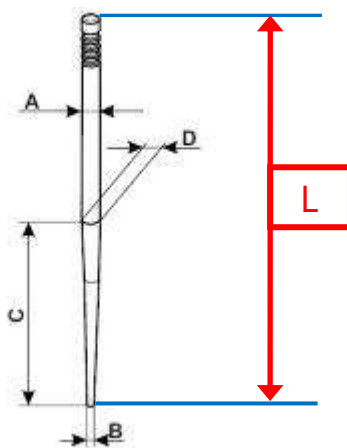

Attention: ALL THE ENGINE PARTS MUST BE ORIGINAL BY VORTEX ROK.

Neither engines nor accessories can be modified. By this we mean any shape, content or function changes which may differ from what previously conceived. Furthermore this includes any addition and /or removal of material and /or parts from the engine set-up package unless provided by this regulation.



MINI ROK

2.1

Table of Needle Specifications as per Supplier Chart (Dellorto) NOTE: Clip Position ONE (1) is TOP of needle (Also as per Master Sample W23 needle from the Vortex Rok Importer)

Type	Value X	Characteristic expressed in millimeters						
		ØA	ØB	C	ØD	E	F	L
W23	23	2.5 ±0.03	0.6 ±0.05	(26 ±0.5)	2.5 ±0.03	-	-	45 ±0.2
			Measured right at the tip	Reference Dimensio				

2.2

The Technical Consultant may also compare the needle to a master sample supplied by the Vortex Rok Importer.

2.2

There must be 1 mixture needle stop (Circlip, #13 on page 2) fitted to the needle.

2.3

No Washer is permitted to be fitted either above or below the circlip.

2.3

Note: The marking <W23= on the needle does wear off after a period time. It is the responsibility of the competitor to ensure that if the marking wears off, that the needle is replaced with a new one.

2.5

Should the technical consultant inspect a needle that the marking is worn off; the needle will be checked with reference to the specification above and / or a master sample. The needle will then be impounded by the TC and the competitor will be required to fit a new needle.

2.6

Wear marks towards the tip of the needle, where the needle goes through the emulsion tube is common. The needle should be replaced if wear is excessive.

3. Atomizer / Emulsion Tube (Mini Rok) (266 AN)

3.1

Length of Emulsion Tube

Spec: 36.00mm ± 0.20mm

3.2

Internal Diameter from side 3.2

GO Spec: 2.66mm (GO)

3.3

Internal Diameter from side 3.3

GO Spec: 3.00mm (GO)

3.4

2 x Rows of 4 holes

GO Spec: 0.80mm (GO)

NO GO Spec: 0.85mm (NO GO)

3.5

2 x rows of 3 holes

GO Spec: 0.80mm (GO)

NO GO Spec: 0.85mm (NO GO)

3.6

Length of Nozzle tip to seating face

Spec: 27.00mm ± 0.20mm

Attention: ALL THE ENGINE PARTS MUST BE ORIGINAL BY VORTEX ROK.

Neither engines nor accessories can be modified. By this we mean any shape, content or function changes which may differ from what previously conceived. Furthermore this includes any addition and /or removal of material and /or parts from the engine set-up package unless provided by this regulation.





MINI ROK

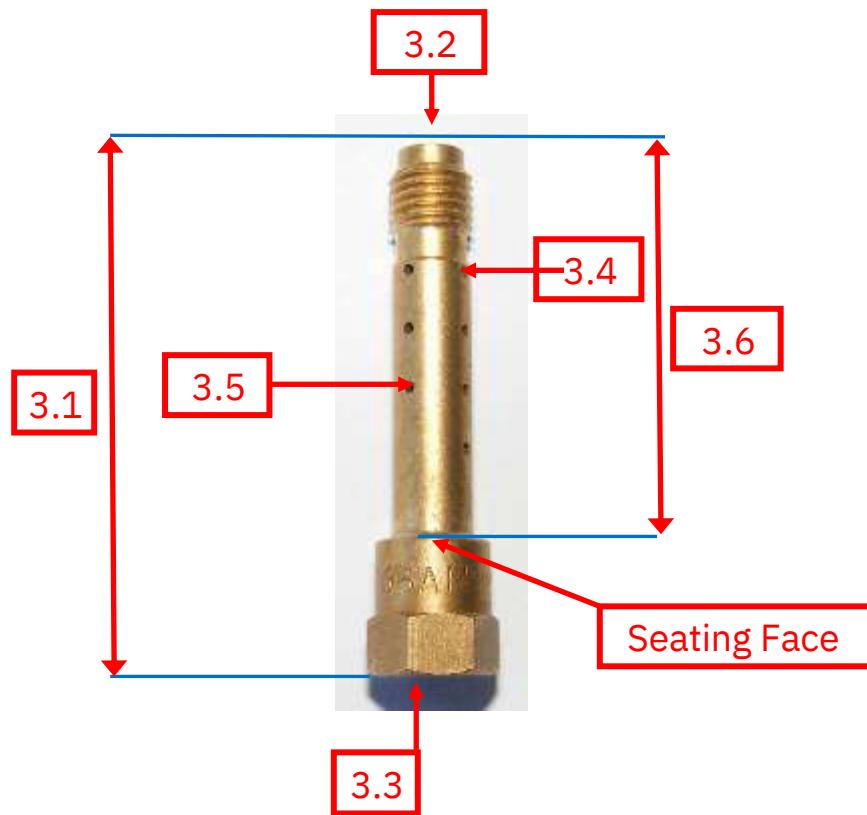

INSERT

3.7 Length of Insert

Spec: 12.00mm ± 0.20mm

3.8 Thickness of Flange

Spec: 1.00mm ± 0.20mm

3.9 Hole Diameter

Spec: 4.90mm ± 0.30mm

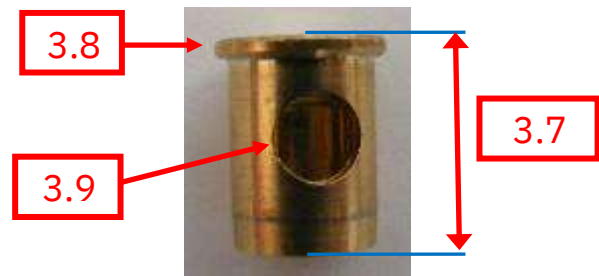

Attention: ALL THE ENGINE PARTS MUST BE ORIGINAL BY VORTEX ROK.

Neither engines nor accessories can be modified. By this we mean any shape, content or function changes which may differ from what previously conceived. Furthermore this includes any addition and /or removal of material and /or parts from the engine set-up package unless provided by this regulation.



MINI ROK

4. Pilot Jet (50)

- 4.1 Length of Pilot Jet
Spec: 9.50mm \pm 0.20mm
- 4.2 Internal Diameter of Smallest hole inside the Pilot Jet
GO Spec: 0.5 mm (**GO**)
NO GO Spec: 0.55 mm (**NO GO**)

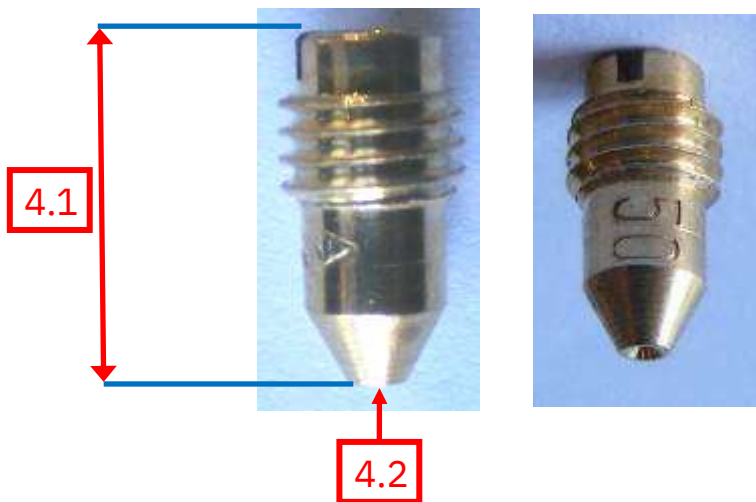

5. Choke Jet (60)

- 5.1 Length of Choke Jet
Spec: 27.00mm \pm 0.25mm
- 5.2 Internal Diameter of hole inside the Choke Jet
GO Spec: 0.60 mm (**GO**)
NO GO Spec: 0.65 mm (**NO GO**)
- 5.3 4 holes, 90° apart
GO Spec: 1.00 mm (**GO**)
NO GO Spec: 1.10 mm (**NO GO**)

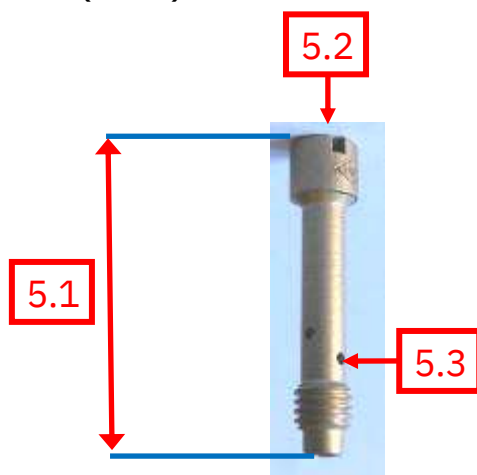

Attention: ALL THE ENGINE PARTS MUST BE ORIGINAL BY VORTEX ROK.

Neither engines nor accessories can be modified. By this we mean any shape, content or function changes which may differ from what previously conceived. Furthermore this includes any addition and /or removal of material and /or parts from the engine set-up package unless provided by this regulation.



MINI ROK

6. Main Jet

The anti-surge plate fitted between the emulsion tube and the main jet may **NOT** be removed.

6.1 Length of Main Jet

Spec: 8.0mm \pm 0.3mm

6.2 Internal diameter of main jet.

Spec: Free

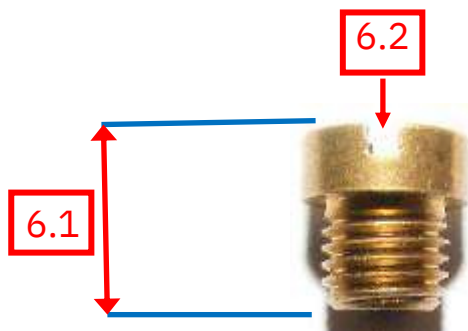

7. Needle & Seat Valve

7.1 Internal Diameter of hole inside the Needle Valve

GO Spec: 1.45 mm (GO)

NO GO Spec: 1.55 mm (NO GO)

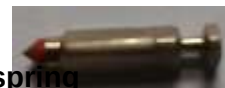

The Only Needle permitted is the solid needle with no spring

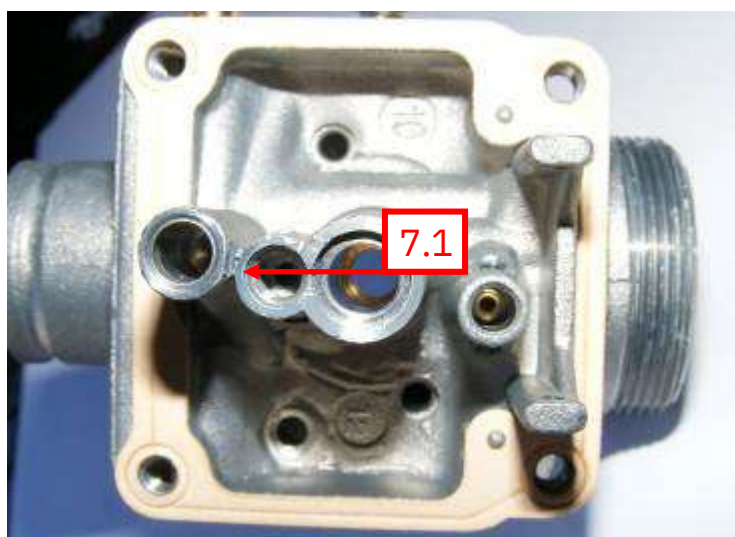

Attention: ALL THE ENGINE PARTS MUST BE ORIGINAL BY VORTEX ROK.

Neither engines nor accessories can be modified. By this we mean any shape, content or function changes which may differ from what previously conceived. Furthermore this includes any addition and /or removal of material and /or parts from the engine set-up package unless provided by this regulation.



MINI ROK

8. Float

8.1 Weight of Float

Spec: 4.0grams (As marked on the bottom of the float)



9. Air Screw

9.1 Diameter of Air Screw Orifice.

GO Spec: 1.10 mm (GO)

NO GO Spec: 1.3 mm (NO GO)



9.2: Diameter of tip end: 0.9mm \pm 0.05mm

9.3: Diameter of tip: 1.2mm \pm 0.05mm



9.4: The Air Screw must be fitted with O-ring, washer and spring as illustrated.

Attention: ALL THE ENGINE PARTS MUST BE ORIGINAL BY VORTEX ROK.

Neither engines nor accessories can be modified. By this we mean any shape, content or function changes which may differ from what previously conceived. Furthermore this includes any addition and /or removal of material and /or parts from the engine set-up package unless provided by this regulation.

A Other Dimensions

A.1 Diameter of Throat.

The throat diameter must be checked from both sides of the carburetor.

Spec: 18.0mm \pm 0.05mm

GO Spec: 17.95 mm (GO)

A.2 NO GO Spec: 18.05 mm (NO GO)

Diameter of hole A2 as illustrated

GO Spec: 1.00 mm (GO)

A.3 NO GO Spec: 1.10 mm (NO GO)

Diameter of hole A3 as illustrated

GO Spec: 2.50 mm (GO)

NO GO Spec: 2.60 mm (NO GO)

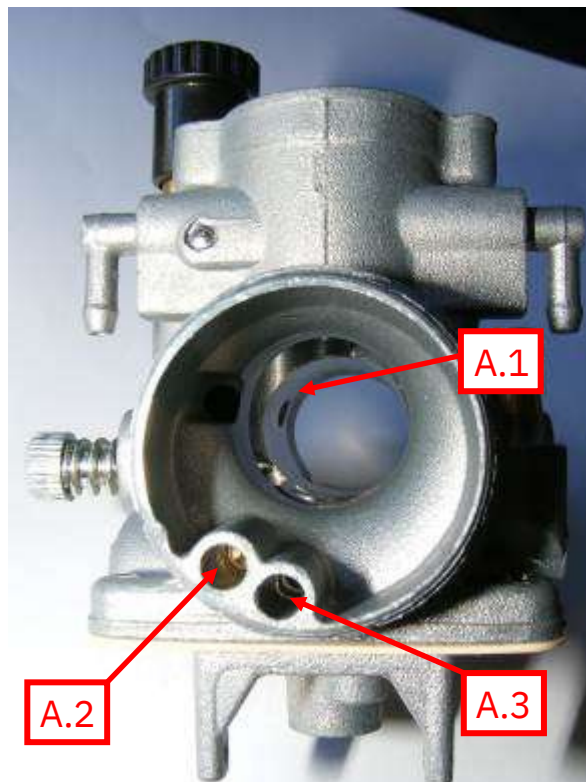
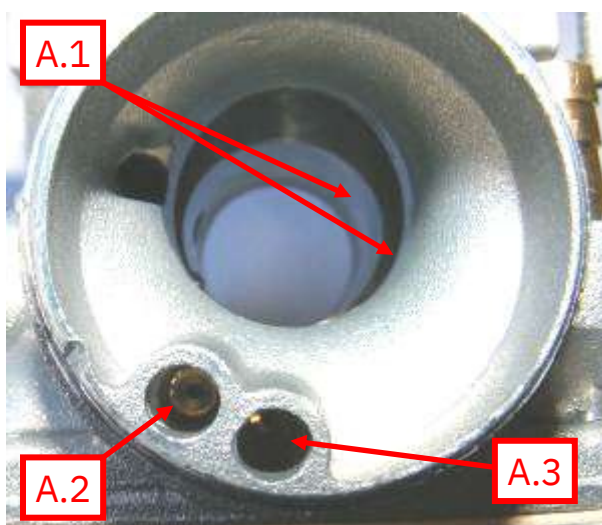

Attention: ALL THE ENGINE PARTS MUST BE ORIGINAL BY VORTEX ROK.

Neither engines nor accessories can be modified. By this we mean any shape, content or function changes which may differ from what previously conceived. Furthermore this includes any addition and /or removal of material and /or parts from the engine set-up package unless provided by this regulation.



MINI ROK

- B.1** Diameter of hole B1 as illustrated
GO Spec: 1.10 mm (GO)
NO GO Spec: 1.30 mm (NO GO)

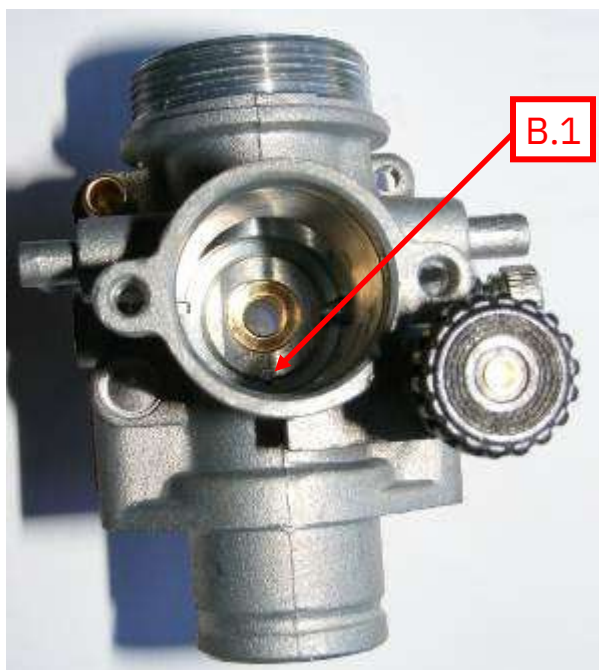

- B.2** Diameter of hole B2 as illustrated
GO Spec: 1.0 mm (GO)
NO GO Spec: 1.1 mm (NO GO)

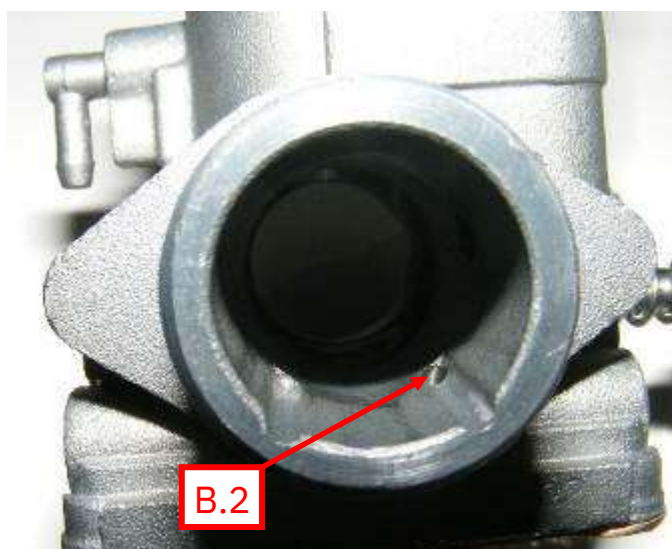

Attention: ALL THE ENGINE PARTS MUST BE ORIGINAL BY VORTEX ROK.

Neither engines nor accessories can be modified. By this we mean any shape, content or function changes which may differ from what previously conceived. Furthermore this includes any addition and /or removal of material and /or parts from the engine set-up package unless provided by this regulation.



MINI ROK

ITEM C IS ONLY FOR REFERENCE UNTIL FURTHER NOTICE

C Emulsion Tube and Insert Protrusion (MINI ROK)

Dimensions are from the center line of the 18.00mm Bore.

C1 Spec: $7.2 \pm 0.5\text{mm}$

C2 Spec: $9.5 \pm 0.5\text{mm}$

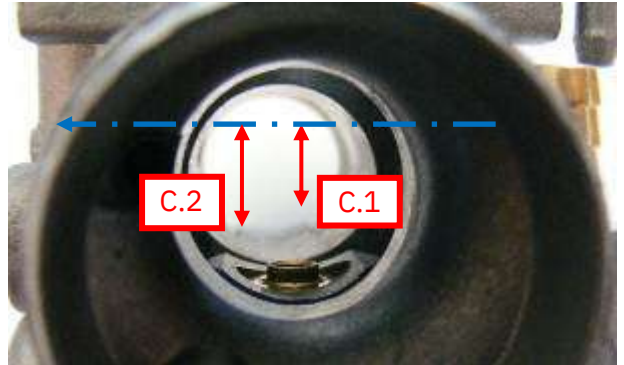

D. General

- The over flow nipples may be turned in any direction
- An overflow pipe may be fitted
- Some carbs have a brass insert fitted inside the overflow tubes (Supplied from Dellorto) on the inside of the carb. This is to prevent <Break through= of internal channels and is permitted

List of tools required

Vernier

17.95mm GO Gauge

18.05 NO GO Gauge

Drill Bits, "GO / NO GO" Gauges Required (mm)

0.5

0.55

0.6

0.65

0.8

0.85

1

1.1

1.2

1.3

1.45

1.55

2.5

2.6

2.66

2.69

2.75

3

3.1

Attention: ALL THE ENGINE PARTS MUST BE ORIGINAL BY VORTEX ROK. _____

Neither engines nor accessories can be modified. By this we mean any shape, content or function changes which may differ from what previously conceived. Furthermore this includes any addition and /or removal of material and /or parts from the engine set-up package unless provided by this regulation.





MINI ROK

Please Note: This is a working document and will be updated as and when required. Should any discrepancies / queries regarding the document arise; the technical working group will investigate and take the required action.

INLET SILENCER	
MODEL TYPE	MINI

CONNECTOR FIXING FILTER-CARBURETOR IN PLASTIC MATERIAL

Attention: ALL THE ENGINE PARTS MUST BE ORIGINAL BY VORTEX ROK.
 Neither engines nor accessories can be modified. By this we mean any shape, content or function changes which may differ from what previously conceived. Furthermore this includes any addition and /or removal of material and /or parts from the engine set-up package unless provided by this regulation.

